

This Detail Drawing may not be altered or changed in any manner except by the City Engineer. It is the responsibility of the user to acquire the most current version.

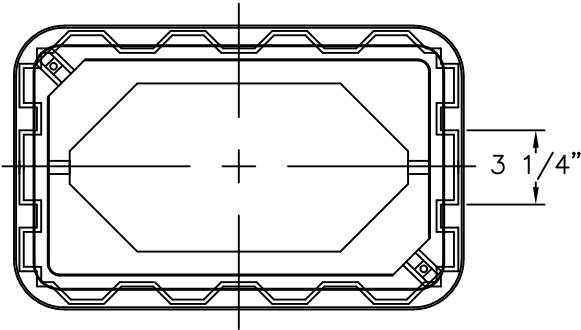

TOP VIEW

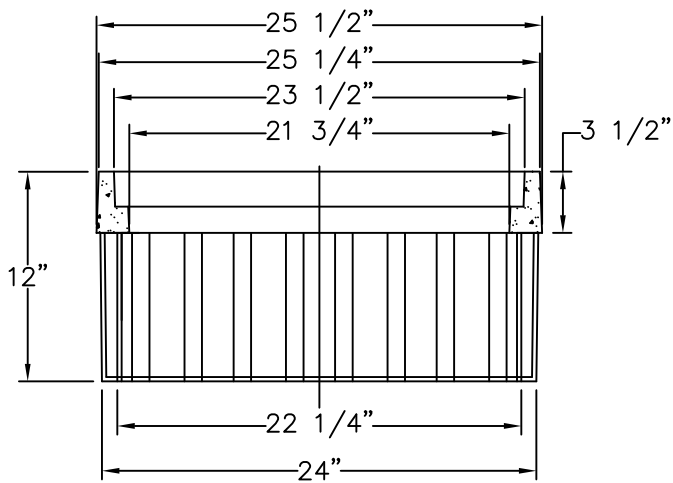
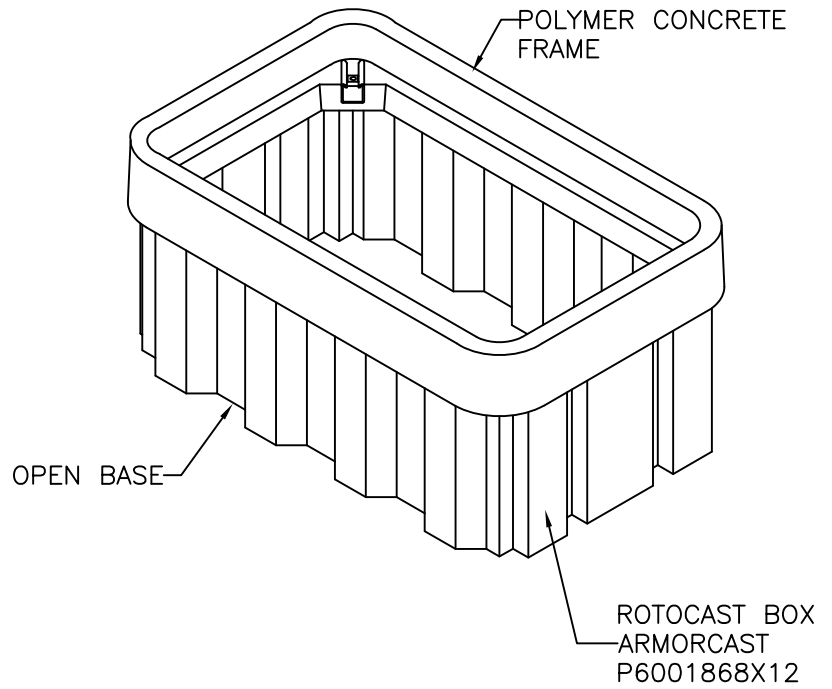

SIDE VIEW

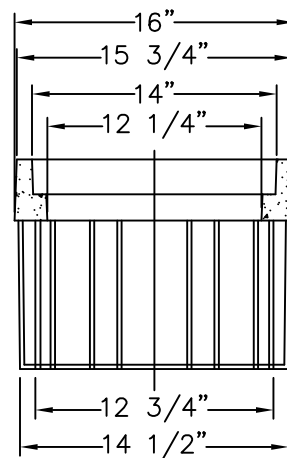

END VIEW

Meter Box - 3/4" & 1" Meter

DRAWING NUMBER: WT-3035

DRAWN BY: SR

SCALE: N.T.S.

FILE NAME: W-3035.DWG

APPROVED BY: NK

DATE: 6/4/14

CITY OF
WILSONVILLE



PUBLIC WORKS STANDARDS