

Frog Pond Crossing

Annexation, Zoning Map Amendment, Tentative Subdivision Plat, Stage I & II Planned Development Review, Site Design Review, Type C Tree Removal Plan

Date: Updated November 2021

Submitted to: City of Wilsonville
29799 SW Town Center Loop East
Wilsonville, OR 97070

Applicant: Venture Properties, Inc.
4230 Galewood Street, Suite 100
Lake Oswego, OR 97135

AKS Job Number: 5252



12965 SW Herman Road, Suite 100
Tualatin, OR 97062
(503) 563-6151



City of Wilsonville
Exhibit B1 DB21-0036 et al

Table of Contents

I.	Executive Summary	2
II.	Site Description/Setting	3
	Project Location	3
	Surrounding Land Use.....	3
	Existing Site Condition.....	3
	Proposed Project.....	3
	Circulation	3
III.	Applicable Review Criteria	4
	OREGON REVISED STATUTES (ORS)	4
	2017 ORS 222.111.....	4
	2017 ORS 222.120.....	4
	2017 ORS 222.170.....	5
	OREGON STATEWIDE PLANNING GOALS	5
	Goal 1: Citizen Involvement	6
	Goal 2: Land Use Planning.....	6
	Goal 5: Natural Resources, Scenic and Historic Areas, and Open Spaces	6
	Goal 6: Air, Water and Land Resources Quality	6
	Goal 8: Recreational Needs	7
	Goal 9: Economic Development	7
	Goal 10: Housing.....	7
	Goal 11: Public Facilities and Services	7
	Goal 12: Transportation.....	8
	FINDINGS FOR TRANSPORTATION PLANNING RULE COMPLIANCE	8
	METRO FUNCTIONAL PLAN COMPLIANCE	11
	CITY OF WILSONVILLE COMPREHENSIVE PLAN.....	12
	URBAN GROWTH MANAGEMENT.....	12
	LAND USE AND DEVELOPMENT	13
	CITY OF WILSONVILLE DEVELOPMENT CODE	14
	CHAPTER 4. ZONING	14
	Section 4.113 STANDARDS APPLYING TO RESIDENTIAL DEVELOPMENTS IN ANY ZONE	14
	Section 4.118 STANDARDS APPLYING IN ALL PLANNED DEVELOPMENT ZONES.....	16
	Section 4.124 STANDARDS APPLYING TO ALL PD RESIDENTIAL ZONES.....	18
	Section 4.127 RESIDENTIAL NEIGHBORHOOD (RN) ZONE.	19
	Section 4.139 SIGNIFICANT RESOURCE OVERLAY ZONE (SROZ) ORDINANCE	32
	Section 4.140 PLANNED DEVELOPMENT REGULATIONS	32
	CHAPTER 4. GENERAL DEVELOPMENT REGULATIONS.....	38
	Section 4.154 ON-SITE PEDESTRIAN ACCESS AND CIRCULATION	38
	Section 4.155 GENERAL REGULATIONS - PARKING, LOADING AND BICYCLE PARKING	39
	Section 4.167 GENERAL REGULATIONS - ACCESS, INGRESS AND EGRESS	39
	Section 4.171 PROTECTION OF NATURAL FEATURES AND OTHER RESOURCES	40
	Section 4.175 PUBLIC SAFETY AND CRIME PREVENTION.....	43
	Section 4.176 LANDSCAPING, SCREENING, AND BUFFERING	43

Section 4.177	STREET IMPROVEMENT STANDARDS	50
Section 4.180	EXCEPTIONS AND MODIFICATIONS - PROJECTIONS INTO REQUIRED YARDS	55
Section 4.181	EXCEPTIONS & MODIFICATIONS - HEIGHT LIMITS.	56
Section 4.182	EXCEPTIONS AND MODIFICATIONS - SETBACK MODIFICATIONS.....	56
Section 4.197	ZONE CHANGES AND AMENDMENTS TO THIS CODE – PROCEDURES	56
CHAPTER 4.	LAND DIVISIONS	59
Section 4.210	APPLICATION PROCEDURE	59
Section 4.236	GENERAL REQUIREMENTS - STREETS	61
Section 4.237	GENERAL REQUIREMENTS – OTHER.....	63
Section 4.250	LOTS OF RECORD	66
Section 4.262	IMPROVEMENTS - REQUIREMENTS	66
CHAPTER 4.	UNDERGROUND UTILITIES.	67
Section 4.300	GENERAL.....	67
Section 4.320	REQUIREMENTS.....	67
CHAPTER 4.	SITE DESIGN REVIEW	68
Section 4.421	CRITERIA AND APPLICATION OF DESIGN STANDARDS.....	68
Section 4.440	PROCEDURE.....	70
CHAPTER 4.	TREE PRESERVATION AND PROTECTION.....	71
Section 4.600.30	TREE REMOVAL PERMIT REQUIRED	71
Section 4.600.50	APPLICATION FOR TREE REMOVAL PERMIT	71
Section 4.610.00	APPLICATION REVIEW PROCEDURE	72
Section 4.610.10	STANDARDS FOR TREE REMOVAL, RELOCATION OR REPLACEMENT	73
Section 4.610.40	TYPE C PERMIT	75
Section 4.620.00	TREE RELOCATION, MITIGATION, OR REPLACEMENT.....	77
Section 4.620.10	TREE PROTECTION DURING CONSTRUCTION.....	78
CHAPTER 4.	ANNEXATIONS AND URBAN GROWTH BOUNDARY AMENDMENTS.....	79
Section 4.700	PROCEDURES RELATING TO THE PROCESSING OF REQUESTS FOR ANNEXATION AND URBAN GROWTH BOUNDARY AMENDMENTS.....	79
IV.	Conclusion	80

Tables

Table 1. Proposed Residential Units	22
Table 2. Compliance with Neighborhood Zone Lot Development Standards	26
Table 3. Required Open Space	28

Exhibits

Exhibit A: Preliminary Plans

Exhibit B: Land Use Application Forms

Exhibit C: Title Report

Exhibit D: Clackamas County Assessor's Map

Exhibit E: Traffic Impact Study

Exhibit F: SROZ Verification Report

Exhibit G: Preliminary Stormwater Report

Exhibit H: Geotechnical Report

Exhibit I: Draft CC&Rs

Exhibit J: Annexation Petition and Certification

Exhibit K: Annexation Legal Description, Exhibit, and Certification

Exhibit L: Zoning Change Legal Description and Exhibit

Exhibit M: Preliminary Conceptual Elevations

Exhibit N: 250-Foot Radius Notification Labels

Exhibit O: BPA Easement

Exhibit P: TVF&R Service Provider Letter

Exhibit Q: Fire Truck Turning Exhibit

Exhibit U: Republic Services Site Plan Approval

Frog Pond Lane – Venture/Chaney Subdivision

Submitted to:	City of Wilsonville
Applicant:	Venture Properties, LLC 4230 Galewood Street, Suite 100 Lake Oswego, Oregon 97135
Property Owners:	Chaney Paul C Co-Trustee 27227 SW Stafford Road Wilsonville, OR 97070-9728
Applicant’s Consultant:	AKS Engineering & Forestry, LLC 12965 SW Herman Road, Suite 100 Tualatin, OR 97062 Contact(s): Mimi Doukas, AICP, RLA Email: mimid@aks-eng.com Phone: (503) 563-6151
Site Location:	27227 SW Stafford Road
Clackamas County Assessor’s Map:	31W12D; Tax Lots 100, 300, 302
Site Size:	One subdivision affecting three lots at ±8.45 total acres: ±2.02 acres (Lot 100) ±6.44 acres (Lot 300) ±0.02 acres (Lot 302)
Land Use Districts:	County Rural Residential Farm Forest 5-Acre (RRFF5)



I. Executive Summary

Venture Properties, LLC (Applicant) is submitting this application to accommodate a single-family residential neighborhood in Frog Pond West master planned community. The project requires the following approvals:

1. Annexation to the City of Wilsonville
2. Zoning Map Amendment
3. Planned Development – Stage I Preliminary Plan
4. Planned Development – Stage II Final Plan
5. Site Design Review of Open Space
6. Tentative Subdivision Plat
7. Type C Tree Plan
8. Waiver for Small Lot Subdistrict Open Space Location
9. Waiver for Street Frontage for 8 Lots in R7 Subdistrict

This property is located within the Frog Pond West planning area, which Metro Regional Services (Metro) included in its Urban Growth Boundary (UGB) in 2002 to accommodate projected residential growth. The City of Wilsonville undertook extensive planning of Frog Pond West over several years, ultimately adopting the Frog Pond Area Plan in 2015 and Frog Pond West Master Plan in 2017. Annexation of the project site into the City of Wilsonville is the next step in the progression from the thorough planning process and helps implement the City’s vision for this area.

This application involves the development of land for housing. Oregon Revised Statutes (ORS) 197.307(4) states that a local government may apply only clear and objective standards, conditions, and procedures regulating the provision of housing, and that such standards, conditions, and procedures cannot have the effect, either in themselves or cumulatively, of discouraging housing through unreasonable cost or delay. This application involves a “limited land use application,” as that term is defined in ORS 197.015 (12), as it involves a tentative subdivision plan for property within an urban growth boundary.

Oregon Courts and the Land Use Board of Appeals (LUBA) have generally held that an approval standard is not clear and objective if it imposes on an applicant “subjective, value-laden analyses that are designed to balance or mitigate impacts of the development” (Rogue Valley Association of Realtors v. City of Ashland, 35 Or LUBA 139, 158 [1998] aff’d, 158 Or App 1 [1999]). ORS 197.831 places the burden on local governments to demonstrate that the standards and conditions placed on housing applications can be imposed only in a clear and objective manner. While this application addresses all standards and conditions, the Applicant reserves the right to object to the enforcement of standards or conditions that are not clear and objective and does not waive its right to assert that the housing statutes apply to this application. Exceptions in ORS 197.307(4)(a) and 197.307(5) do not apply to this application; ORS 197.307(7)(a) is controlled by ORS 197.307(4).

ORS 197.195(1) describes how certain standards can be applied to a limited land use application. The applicable land use regulations for this subdivision application are found in the City of Wilsonville Development Code. Pursuant to ORS 197.195(1), Comprehensive Plan provisions (as well as goals, policies, etc. from within the adopted elements of the Comprehensive Plan) may not be used as a basis for a decision or an appeal of a decision unless they are specifically incorporated into the City of Wilsonville Development Code.

II. Site Description/Setting

Project Location

The site is approximately 8.45 gross acres with frontage on SW Stafford Road and SW Frog Pond Lane. The property is in unincorporated Clackamas County, within the City of Wilsonville Urban Growth Boundary (UGB) and within the Frog Pond West subarea of the city.

Surrounding Land Use

The property abuts the UGB line and undeveloped rural residential land in Clackamas County to the north. Surrounding properties to the east, south, and west will eventually be built out as the Frog Pond master planned community. The area to the east of the site is part of the future Frog Pond East mixed-use neighborhood, currently undeveloped and still under the jurisdiction of Clackamas County. The adjacent property to the south is within the Frog Pond West subarea zoned Residential Neighborhood (RN), with Frog Pond Area Plan Designations of Medium Lot Single Family (R-7) and Small Lot Single Family (R-5). The Frog Pond Ridge subdivision was recently approved south of Frog Pond Lane and is currently under construction. The adjacent undeveloped property to the west is within the same Frog Pond West Subdistricts 10 and 11 as the project site and it will share its R7 and R5 zoning designations. It will also be annexed to the City and rezoned from Clackamas County Rural Residential Farm Forest 5-Acre (RRFF5) to RN with R-5 and R-7 Frog Pond Area Plan Designations.

Existing Site Condition

The site consists of Tax lots 100, 300, and 302 of Clackamas County Assessor's Map 31W12D and has Clackamas County zoning designation RRFF5. Tax lot 100 has an existing single-family residence, a paved driveway, and a barn. Tax lots 300 and 302 are currently undeveloped. A Bonneville Power Administration (BPA) high-power transmission line corridor runs through the northeastern portion of the site. This BPA transmission easement area measures ± 1.95 acres and will be largely preserved as open space. A ±1.48-acre wetland is present in the northeastern portion of the site, generally within the BPA easement area, and extends off site to the north and to the east. The wetland is not deemed "locally significant," and the Applicant has submitted a Wetland Delineation Report to the Oregon Department of State Lands (DSL).

Proposed Project

The project includes 29 detached single-family lots and active-use open space. This project annexes the site to the City of Wilsonville and applies the RN zone. Per Figure 6 of the Frog Pond West Master Plan, approximately 0.78 gross acres of the site are within Frog Pond West Subdistrict 10, which is designated R-5 (Small Size Lots; 4,000 to 6,000 square-foot lots) and are planned for five lots. Approximately 7.67 gross acres of the site are within Subdistrict 11, which is designated R-7 (Medium Size Lots; 6,000 to 8,000 square-foot-lots), and are planned for 24 lots, open space tracts with pedestrian trails, a stormwater facility, and an electric transmission line easement corridor.

Associated site improvements include grading, construction of a local street network, open space tracts to be privately maintained by the homeowners' association (HOA), a brick wall along Stafford Road, and a landscaped public utility easement (PUE) along Stafford Road. The project dedicates 12 feet of right-of-way width for the planned future expansion of SW Stafford Road and 10 feet of right-of-way width for the planned future expansion of SW Kahle Road.

Circulation

The 29-lot subdivision has a single access point from SW Frog Pond Lane, which is a collector-gateway street with a median, one travel lane in each direction, and a buffered bike lane on each side of the road.

SW Frog Pond Lane provides connection to SW Stafford Road to the east, an arterial street. The new local streets are 28 feet wide with one travel lane in each direction and parking on both sides.

III. **Applicable Review Criteria**

OREGON REVISED STATUTES (ORS)

2017 ORS 222.111

Authority and Procedure for Annexation

- (1) When a proposal containing the terms of annexation is approved in the manner provided by the charter of the annexing city or by ORS 222.111 (Authority and procedure for annexation) to 222.180 (Effective date of annexation) or 222.840 (Short title) to 222.915 (Application of ORS 222.840 to 222.915), the boundaries of any city may be extended by the annexation of territory that is not within a city and that is contiguous to the city or separated from it only by a public right of way or a stream, bay, lake or other body of water. Such territory may lie either wholly or partially within or without the same county in which the city lies.

Response: The property is within unincorporated Clackamas County and is contiguous to the Wilsonville City Limits.

- (2) A proposal for annexation of territory to a city may be initiated by the legislative body of the city, on its own motion, or by a petition to the legislative body of the city by owners of real property in the territory to be annexed.

Response: The proposal for annexation is initiated by the property owners. The signed petition for annexation to City of Wilsonville is included in Exhibit B.

- (5) The legislative body of the city shall submit, except when not required under ORS 222.120 (Procedure for annexation without election), 222.170 (Annexation by consent before public hearing or order for election) and 222.840 (Short title) to 222.915 (Application of ORS 222.840 to 222.915) to do so, the proposal for annexation to the electors of the territory proposed for annexation and, except when permitted under ORS 222.120 (Procedure for annexation without election) or 222.840 (Short title) to 222.915 (Application of ORS 222.840 to 222.915) to dispense with submitting the proposal for annexation to the electors of the city, the legislative body of the city shall submit such proposal to the electors of the city. The proposal for annexation may be voted upon at a general election or at a special election to be held for that purpose.
- (6) The proposal for annexation may be voted upon by the electors of the city and of the territory simultaneously or at different times not more than 12 months apart.
- (7) Two or more proposals for annexation of territory may be voted upon simultaneously; however, in the city each proposal shall be stated separately on the ballot and voted on separately, and in the territory proposed for annexation no proposal for annexing other territory shall appear on the ballot.

Response: Pursuant to ORS 222.120(1), the legislative body of the City of Wilsonville is not required to submit a proposal for annexation of territory to the electors of the city for their approval or rejection. The above criteria are not applicable.

2017 ORS 222.120

Procedure for Annexation Without Election



Except when expressly required to do so by the city charter, the legislative body of a city is not required to submit a proposal for annexation of territory to the electors of the city for their approval or rejection.

Response: The City of Wilsonville Charter does not require a vote of the electors of the city for annexation. The property owners of the subject site consent in writing to the annexation and upon submittal of this application a public hearing will be scheduled. The above criterion is met.

2017 ORS 222.170

If the city legislative body has not dispensed with submitting the question to the electors of the city and a majority of the votes cast on the proposition within the city favor annexation, or if the city legislative body has previously dispensed with submitting the question to the electors of the city as provided in ORS 222.120 (Procedure for annexation without election), the legislative body, by resolution or ordinance, shall set the final boundaries of the area to be annexed by a legal description and proclaim the annexation.

Response: The draft legal description and exhibit map for annexation are included within Exhibit K. The criterion above is understood.

- (4) Real property that is publicly owned, is the right of way for a public utility, telecommunications carrier as defined in ORS 133.721 (Definitions for ORS 41.910 and 133.721 to 133.739) or railroad or is exempt from ad valorem taxation shall not be considered when determining the number of owners, the area of land or the assessed valuation required to grant consent to annexation under this section unless the owner of such property files a statement consenting to or opposing annexation with the legislative body of the city on or before a day described in subsection (1) of this section.

Response: The above standard is understood.

OREGON STATEWIDE PLANNING GOALS

The following Oregon Statewide Planning Goals are applicable to this action:

- Goal 1 – Citizen Involvement
- Goal 2 – Land Use Planning
- Goal 6 – Air, Land, and Water Resources Quality
- Goal 8 – Recreational Needs
- Goal 9 – Economic Development
- Goal 10 – Housing
- Goal 11 – Public Facilities and Services
- Goal 12 – Transportation

Goal 3 (Agricultural Lands) and Goal 4 (Forest Lands) are not applicable to lands within the UGB and have been omitted for brevity.

Goal 7 (Areas Subject to Natural Hazards) is not applicable because the subject site does not contain mapped areas of steep slopes 25 percent or greater or other known hazard areas.

Goal 13 (Energy Conservation) is not applicable because the amendment does not affect the City or County goals or policies governing energy conservation.

Goal 14 (Urbanization) is not applicable because this application does not involve expansion of the Wilsonville UGB and thus analysis of the transition of rural to urban land uses is not relevant.

Goals 15 (Willamette River Greenway), 16 (Estuarine Resources), 17 (Coastal Shorelands), 18 (Beaches and Dunes), and 19 (Ocean Resources) are not applicable because the subject site does not contain lands described in those goals.

Goal 1: Citizen Involvement

To develop a citizen involvement program that ensures the opportunity for citizens to be involved in all phases of the planning process.

Response: The City of Wilsonville has an established public notice and hearing process for quasi-judicial applications. Once this annexation request is accepted as complete, the City will begin this public notification and citizen involvement process. Therefore, this request is consistent with Goal 1.

Goal 2: Land Use Planning

To establish a land use planning process and policy framework as a basis for all decision and actions related to use of land and to assure an adequate factual base for such decisions and actions.

Response: The Oregon Land Conservation and Development Commission (LCDC) has acknowledged the City of Wilsonville Comprehensive Plan to be in compliance with the Statewide Planning Goals. This narrative demonstrates that the proposed amendment is in compliance with the goals and policies of the City of Wilsonville Comprehensive Plan, as applicable to the proposed annexation.

This application provides an adequate factual basis for the City and County to approve the application because it describes the current and planned future site characteristics and applies the relevant approval criteria to those characteristics. Therefore, following the application process will ensure consistency with Statewide Planning Goal 2.

Goal 5: Natural Resources, Scenic and Historic Areas, and Open Spaces

To protect natural resources and conserve scenic and historic areas and open spaces.

Response: The subject property is not designated as an open space or scenic area, and there are no protected natural resources or historic areas present on the site. The project provides ±2.9 acres of open space. The proposal conforms to this statewide planning goal.

Goal 6: Air, Water and Land Resources Quality

To maintain and improve the quality of the air, water and land resources of the state.

Response: Land located within the Urban Growth Boundary is considered urbanizable and is intended to be developed to meet the needs of the City. The effects of urban development on air, water and land resources are anticipated. Development of the property is subject to tree preservation, stormwater, and wastewater requirements of the City of Wilsonville Development Code which are intended to minimize the impact of development on the state's natural resources. The proposal is consistent with Goal 6.

Goal 8: Recreational Needs

To satisfy the recreational needs of the citizens of the state and visitors and, where appropriate, to provide for the siting of necessary recreational facilities including destination resorts.

Response: Goal 8 is implemented through the City of Wilsonville 2018 Parks and Recreation Comprehensive Master Plan. Together with the Metro Plan, the provisions identify future needs for parks, a natural area, and recreation facilities. The amendments will not negatively affect the City's Comprehensive Plan with respect to Goal 8 and its development regulations governing recreational needs (e.g. open space, park dedication, fee in-lieu-of requirements, etc.). An increase in residential land supply will increase the number of residents and visitors and in turn System Development Charges (SDC) and the demand for recreational facilities will increase. Therefore, this application is consistent with Goal 8.

Goal 9: Economic Development

To provide adequate opportunities throughout the state for a variety of economic activities vital to the health, welfare, and prosperity of Oregon's citizens.

Response: This area has been identified in the City of Wilsonville Comprehensive Plan as appropriate for residential use. The Zone Map Amendment to change the zoning from unincorporated Clackamas County Rural Residential Farm Forest 5-Acre (RRFF-5) to Residential Neighborhood (RN) is consistent with the intent of the Frog Pond West Master Plan. The proposed project will create the needed housing for the City of Wilsonville's workforce, which indirectly promotes economic activities in the region. In addition, a thoughtfully designed community with active-use open space and pedestrian trail system enhances the City's appeal, stimulating its business and industry and contributing to the health and vitality of the overall community. Therefore, this application is consistent with Goal 9.

Goal 10: Housing

To provide for the housing needs of citizens of the state.

Response: The 2014 Wilsonville Residential Land Study, which serves as the City's state-acknowledged Housing Needs Analysis, anticipates that the City will need to accommodate 3,794 new households by 2034. The Frog Pond West master planned community has been planned with a strategy to meet state-required supply for residential land and housing. The project provides 29 single-family lots at allowable residential density for medium- and small-lot single-family homes. Therefore, this application is consistent with Goal 10.

Goal 11: Public Facilities and Services

To plan and develop a timely, orderly and efficient arrangement of public facilities and services to serve as a framework for urban and rural development.

Response: The City of Wilsonville Comprehensive Plan and the Frog Pond West Master Plan include implementation measures to ensure site development complies with the City's Wastewater Collections System Master plan, Stormwater Master Plan, Water System Master Plan, and Transportation System Plan. Therefore, the proposed annexation implements the Comprehensive Plan the Master Plan and is consistent with Goal 11.

Goal 12: Transportation

To provide and encourage a safe, convenient and economic transportation system.

Response: Goal 12 is implemented by the Transportation Planning Rule (TPR), which requires local governments to adopt Transportation System Plans (TSPs) and consider transportation impacts resulting from land use decisions and development. This application includes a Transportation Impacts Study (TIS) prepared by DKS (Exhibit E). It demonstrates that the project will not have a “significant effect” on the surrounding transportation system. Therefore, the application is consistent with Goal 12.

FINDINGS FOR TRANSPORTATION PLANNING RULE COMPLIANCE

Response: The key provision of the TPR related to local land use decisions is Oregon Administrative Rule (OAR) 660-012-0060. OAR 660-012-0060(1) and (2) apply to amendments to acknowledged maps, as is the case with this application.

The TPR requires a two-step analysis. First, under OAR 660-012-0060(1), the Applicant must determine if the application has a “significant affect,” as that term is defined in OAR 660-012-0060(1). The City may rely on transportation improvements found in Transportation System Plans (TSPs), as allowed by OAR 660-012-0060(3)(a), (b), and (c), to show that failing intersections will not be made worse or intersections not now failing will not fail. If there is a “significant affect,” then the Applicant must demonstrate appropriate mitigation under OAR 660-012-0060(2), et seq.

OAR 660-012-0060 Plan and Land Use Regulation Amendments

- (1) If an amendment to a functional plan, an acknowledged comprehensive plan, or a land use regulation (including a zoning map) would significantly affect an existing or planned transportation facility, then the local government must put in place measures as provided in section (2) of this rule, unless the amendment is allowed under section (3), (9) or (10) of this rule. A plan or land use regulation amendment significantly affects a transportation facility if it would:
 - (a) Change the functional classification of an existing or planned transportation facility (exclusive of correction of map errors in an adopted plan);
 - (b) Change standards implementing a functional classification system; or
 - (c) Result in any of the effects listed in paragraphs (A) through (C) of this subsection based on projected conditions measured at the end of the planning period identified in the adopted TSP. As part of evaluating projected conditions, the amount of traffic projected to be generated within the area of the amendment may be reduced if the amendment includes an enforceable, ongoing requirement that would demonstrably limit traffic generation, including, but not limited to, transportation demand management. This reduction may diminish or completely eliminate the significant effect of the amendment.

- (A) Types or levels of travel or access that are inconsistent with the functional classification of an existing or planned transportation facility;
- (B) Degrade the performance of an existing or planned transportation facility such that it would not meet the performance standards identified in the TSP or comprehensive plan; or
- (C) Degrade the performance of an existing or planned transportation facility that is otherwise projected to not meet the performance standards identified in the TSP or comprehensive plan.

Response: The TIS prepared by DKS contains a detailed discussion of the traffic impacts associated with the proposed project and any potential mitigation for the project as it relates to the Oregon Transportation Planning Rule (TPR) found in OAR 660-012-0060. As described in the study, this project and the associated traffic improvements will comply with OAR 660-012-0060 (1) and (2). Please refer to the TIS for further information. The criteria are met.

(...)

- (4) Determinations under sections (1)–(3) of this rule shall be coordinated with affected transportation facility and service providers and other affected local governments.
 - (a) In determining whether an amendment has a significant effect on an existing or planned transportation facility under subsection (1)(c) of this rule, local governments shall rely on existing transportation facilities and services and on the planned transportation facilities, improvements and services set forth in subsections (b) and (c) below.
 - (b) Outside of interstate interchange areas, the following are considered planned facilities, improvements and services:
 - (A) Transportation facilities, improvements or services that are funded for construction or implementation in the Statewide Transportation Improvement Program or a locally or regionally adopted transportation improvement program or capital improvement plan or program of a transportation service provider.
 - (B) Transportation facilities, improvements or services that are authorized in a local transportation system plan and for which a funding plan or mechanism is in place or approved. These include, but are not limited to, transportation facilities, improvements or services for which: transportation systems development charge revenues are being collected; a local

improvement district or reimbursement district has been established or will be established prior to development; a development agreement has been adopted; or conditions of approval to fund the improvement have been adopted.

- (C) Transportation facilities, improvements or services in a metropolitan planning organization (MPO) area that are part of the area's federally-approved, financially constrained regional transportation system plan.
 - (D) Improvements to state highways that are included as planned improvements in a regional or local transportation system plan or comprehensive plan when ODOT provides a written statement that the improvements are reasonably likely to be provided by the end of the planning period.
 - (E) Improvements to regional and local roads, streets or other transportation facilities or services that are included as planned improvements in a regional or local transportation system plan or comprehensive plan when the local government(s) or transportation service provider(s) responsible for the facility, improvement or service provides a written statement that the facility, improvement or service is reasonably likely to be provided by the end of the planning period.
- (c) Within interstate interchange areas, the improvements included in (b)(A)–(C) are considered planned facilities, improvements and services, except where:
- (A) ODOT provides a written statement that the proposed funding and timing of mitigation measures are sufficient to avoid a significant adverse impact on the Interstate Highway system, then local governments may also rely on the improvements identified in paragraphs (b)(D) and (E) of this section; or
 - (B) There is an adopted interchange area management plan, then local governments may also rely on the improvements identified in that plan and which are also identified in paragraphs (b)(D) and (E) of this section.
- (d) As used in this section and section (3):
- (A) Planned interchange means new interchanges and relocation of existing interchanges that are authorized in an

adopted transportation system plan or comprehensive plan;

(B) Interstate highway means Interstates 5, 82, 84, 105, 205 and 405; and

(C) Interstate interchange area means:

(i) Property within one-quarter mile of the ramp terminal intersection of an existing or planned interchange on an Interstate Highway; or

(ii) The interchange area as defined in the Interchange Area Management Plan adopted as an amendment to the Oregon Highway Plan.

(e) For purposes of this section, a written statement provided pursuant to paragraphs (b)(D), (b)(E) or (c)(A) provided by ODOT, a local government or transportation facility provider, as appropriate, shall be conclusive in determining whether a transportation facility, improvement or service is a planned transportation facility, improvement or service. In the absence of a written statement, a local government can only rely upon planned transportation facilities, improvements and services identified in paragraphs (b)(A)-(C) to determine whether there is a significant effect that requires application of the remedies in section (2).

RESPONSE: This section of the Transportation Planning Rule requires coordination with affected transportations service providers. The City provides the roads that serve the subject property. Stafford Road is designated as a Minor Arterial and Frog Pond Lane is designated as a Local Road in the City TSP and both streets are under City jurisdiction. The City has a duty to coordinate with transportation facility and service providers and other affected agencies, as applicable. Therefore, the criteria of OAR 660-012-0060 (4) are met.

METRO FUNCTIONAL PLAN COMPLIANCE

RESPONSE: Metro Code 3.07.810(c) requires compliance with applicable provisions of the Functional Plan when a City amends its acknowledged comprehensive plan and land use regulations. In this case, the City’s acknowledged Land Use Zoning Map and Land Development Code are consistent with the Functional Plan. This application does not amend the City’s acknowledged Land Use Zoning Map or Land Development Code in a way that is

inconsistent with the Functional Plan. Therefore, the City can find that the Functional Plan is satisfied.

Additionally, Metro Code 3.07.810(f) requires that the City give notice to the Metro Chief Operating Officer of the map amendments 35 days before the first Planning Commission hearing. If the City provides such notice, the Land Use Zoning Map Amendment will comply with the Functional Plan upon final approval by the City.

CITY OF WILSONVILLE COMPREHENSIVE PLAN

URBAN GROWTH MANAGEMENT

Urban Growth Boundaries

Goal 2.1 To allow for urban growth while maintaining community livability, consistent with the economics of development, City administration, and the provision of public facilities and services.

Policy 2.2.1 The City of Wilsonville shall support the development of all land within the City, other than designated open space lands, consistent with the land use designations of the Comprehensive Plan.

Implementation Measure 2.2.1.a

Allow annexation when it is consistent with future planned public services and when a need is clearly demonstrated for immediate urban growth.

Response: The proposed project is located within the West Neighborhood of the Frog Pond planning area. The Frog Pond Area Plan was adopted in 2015 and the Frog Pond West Master Plan was adopted in 2017 as a sub-element of the Comprehensive Plan. It provides for single-family residential uses to meet the housing needs of Wilsonville’s growing population. The City’s Housing Needs Analysis validates the need for inclusion of the Frog Pond West subarea to meet state-required supply for residential land. The Frog Pond Area Plan includes a transportation network, parks and open space framework, and infrastructure funding plan to support development within the Frog Pond area and assure adequate public services.

Implementation Measure 2.2.1.e

Changes in the City boundary will require adherence to the annexation procedures prescribed by State law and Metro standards. Amendments to the City limits shall be based on consideration of:

1. Orderly, economic provision of public facilities and services, i.e., primary urban services are available and adequate to serve additional development or improvements are scheduled through the City’s approved Capital Improvements Plan.

Response: The Frog Pond Area Plan includes implementation measures to ensure the orderly and economic provision of public facilities and services for the Frog Pond Area, including Frog Pond West master planned community. The applicant has submitted concurrent applications for Stage I and Stage II Planned Development Review, Site Design Review,

and Tentative Subdivision Plat, which propose the extension of public facilities and services to the Frog Pond Crossing neighborhood. These proposed services are generally consistent with the Frog Pond Area Plan, Frog Pond West Master Plan, and the City's Finance Plan and Capital Improvements Plan.

2. **Availability of sufficient land for the various uses to ensure choices in the marketplace for a 3 to 5 year period.**

Response: The proposed project implements the uses envisioned in the adopted Frog Pond West Master Plan, on the land with zoned Residential Neighborhood (RN). The inclusion of the Frog Pond area within the UGB and the adoption of the Frog Pond Area Plan demonstrate the need for residential development in the Frog Pond Area.

3. **Statewide Planning Goals.**

Response: A separate section in this narrative demonstrates compliance with Statewide Planning Goals.

4. **Applicable Metro Plans;**

Response: A separate section in this narrative demonstrates compliance with the applicable provisions of the Metro Urban Growth Management Functional Plan.

5. **Encouragement of development within the City limits before conversion of urbanizable (UGB) areas.**

Response: The subject site was brought into the UGB in 2002 but has not been annexed to the City limits yet. However, the City began the planning process for the development of the Frog Pond Area in 2014. Annexation of the project site is the next stage of the process and will allow the City of Wilsonville to implement the vision of the Frog Pond West Master Plan.

LAND USE AND DEVELOPMENT

Residential Development

GOAL 4.1 To have an attractive, functional, economically vital community with a balance of different types of land uses.

Policy 4.1.4

The City of Wilsonville shall provide opportunities for a wide range of housing types, sizes, and densities at prices and rent levels to accommodate people who are employed in Wilsonville.

Implementation Measure 4.1.4.b

Plan for and permit a variety of housing types consistent with the objectives and policies set forth under this section of the Comprehensive Plan, while maintaining a reasonable balance between the economics of building and the cost of supplying public services. It is the City's desire to provide a variety of housing types needed to meet a wide range of personal preferences and income levels. The City also recognizes the fact that adequate public facilities and services must be available in order to build and maintain a decent, safe, and healthful living environment.

Response: The proposed annexation of the property and zone change to Residential Neighborhood (RN) implement the Comprehensive Plan to provide new single-family homes, consistent with the residential densities and housing types established in the Frog Pond West Master Plan. The proposed project will provide adequate public facilities and services for the new dwellings.

Implementation Measure 4.1.4.d

Encourage the construction and development of diverse housing types, but maintain a general balance according to housing type and geographic distribution, both presently and in the future. Such housing types may include, but shall not be limited to: Apartments, single-family detached, single-family common wall, manufactured homes, mobile homes, modular homes, and condominiums in various structural forms.

Response: The project provides detached single-family housing on lots ranging from approximately 4,000 square feet to 8,600 square feet, as allowed by the R-5 and R-7 district regulations established in the Frog Pond West Master Plan.

Implementation Measure 4.1.4.e

Targets are to be set in order to meet the City’s Goals for housing and assure compliance with State and regional standards.

Response: The Frog Pond Area Plan and Frog Pond West Master Plan establish minimum and maximum residential densities for this area in compliance with State and regional standards. The proposed zone change will allow development of the subject site in conformance with those targets.

Implementation Measure 4.1.4.r

All development, except as indicated in the lowest density districts, will coincide with the provision of adequate streets, water, and sanitary sewerage and storm drainage facilities, as specified in the Public Facilities and Services Section of the Plan. These facilities shall be (a) capable of adequately serving all intervening properties as well as the proposed development and (b) designed to meet City standards.

Response: Frog Pond Crossing follows the sequential development pattern of Frog Pond West master planned community and extends the public facilities north from the previously approved Frog Pond Ridge subdivision.

CITY OF WILSONVILLE DEVELOPMENT CODE

CHAPTER 4. ZONING

Section 4.113 **STANDARDS APPLYING TO RESIDENTIAL DEVELOPMENTS IN ANY ZONE**

(.01) **Open Space**

Response: The Frog Pond West Master Plan controls open space standards for the area. Please refer to response under Wilsonville Development Code (WDC) Section 4.127(.09).

(.02) **Building Setbacks**



Response: The Frog Pond West Master Plan controls development standards for the area. The setbacks in the proposed project are consistent with the Frog Pond West Master Plan. Please refer to response under WDC Section 4.127(.08).

(.03) Height Guidelines

Response: This application involves a preliminary subdivision plat, therefore only lot dimensional standards are reviewed with this application. Site development standards (setbacks, height, etc.) are applied at the time of building permit review.

(.05) Off Street Parking: Off-street parking shall be provided as specified in Section 4.155.

Response: Please refer to response under WDC Section 4.155.

(.06) Signs: Signs shall be governed by the provisions of Sections 4.156.01 – 4.156.11.

Response: This project does not include signs.

(.07) Fences:

- A. The maximum height of a sight-obscuring fence located in the required front yard of a residential development shall not exceed four (4) feet.
- B. The maximum height of a sight-obscuring fence located in the side yard of a residential lot shall not exceed four (4) feet forward of the building line and shall not exceed six (6) feet in height in the rear yard, except as approved by the Development Review Board. Except, however, that a fence in the side yard of residential corner lot may be up to six (6) feet in height, unless a greater restriction is imposed by the Development Review Board acting on an application. A fence of up to six (6) feet in height may be constructed with no setback along the side, the rear, and in the front yard of a residential lot adjoining the rear of a corner lot as shown in the attached Figure.
- C. Notwithstanding the provisions of Section 4.122(10)(a) and (b), the Development Review Board may require such fencing as shall be deemed necessary to promote and provide traffic safety, noise mitigation, and nuisance abatement, and the compatibility of different uses permitted on adjacent lots of the same zone and on adjacent lots of different zones.

Response: Fences in residential lots will be reviewed at the time of building permit. This application includes fences around open space tracts and the stormwater facility. Please refer to response under WDC Section 4.176 Landscaping, Screening, and Buffering.

(.08) Corner Vision: Vision clearance shall be provided as specified in Section 4.177, or such additional requirements as specified by the City Engineer.

Response: Please refer to response under WDC Section 4.177.

(.09) Prohibited Uses:

- A. Uses of structures and land not specifically permitted in the applicable zoning districts.
- B. The use of a trailer, travel trailer or mobile coach as a residence, except as specifically permitted in an approved RV park.
- C. Outdoor advertising displays, advertising signs, or advertising structures except as provided in Sections 4.156.05, 4.156.07, 4.156.09, and 4.156.10.

Response: The project does not include any prohibited uses.

(.10) Accessory Dwelling Units.

-
- A. Accessory Dwelling Units are permitted subject to standards and requirements of this Subsection. [Amended by Ord. #825, 10/15/18]

Response: The project does not include accessory units.

- (.11) Reduced Setback Agreements. The following procedure has been created to allow the owners of contiguous residential properties to reduce the building setbacks that would typically be required between those properties, or to allow for neighbors to voluntarily waive the solar access provisions of Section 4.137. Setbacks can be reduced to zero through the procedures outlined in this subsection.

Response: Please refer to response under WDC Section 4.127(.08).

Section 4.118 STANDARDS APPLYING IN ALL PLANNED DEVELOPMENT ZONES

- (.01) Height Guidelines: In “S” overlay zones, the solar access provisions of Section 4.137 shall be used to determine maximum building heights. In cases that are subject to review by the Development Review Board, the Board may further regulate heights as follows: [...]

Response: The subject site is not located within the “S” overlay zone.

- (.02) Underground Utilities shall be governed by Sections 4.300 to 4.320. All utilities above ground shall be located so as to minimize adverse impacts on the site and neighboring properties.

Response: Please refer to response under Sections 4.300 to 4.320 in this narrative.

- (.03) Notwithstanding the provisions of Section 4.140 to the contrary, the Development Review Board, in order to implement the purposes and objectives of Section 4.140, and based on findings of fact supported by the record may:

A. Waive the following typical development standards:

1. minimum lot area;
2. lot width and frontage;
3. height and yard requirements;
4. lot coverage;
5. lot depth;
6. street widths;
7. sidewalk requirements;
8. height of buildings other than signs;
9. parking space configuration and drive aisle design;
10. minimum number of parking or loading spaces;
11. shade tree islands in parking lots, provided that alternative shading is provided;
12. fence height;
13. architectural design standards;
14. transit facilities; and
15. On-site pedestrian access and circulation standards; and
16. Solar access standards, as provided in section 4.137.

[Amended by Ord. #719, 6/17/13.]

Response: The applicant requests reduced lot sizes for eight lots in Subdistrict 11, pursuant to WDC Section 4.127(.08), which allows lots 80 percent of the minimum size where necessary to reserve natural resources and provide active open space. Please refer to response under WDC Section 4.127(.08).

While the project meets the applicable requirements for lot dimensional standards, including lot area, width, depth and lot coverage, the application includes a request for a waiver for frontage. Eight lots in Subdistrict 11/R7 have frontage on a shared open space with pedestrian access and have legal lot access via a private alley. Please refer to response under WDC Section 4.127(.08).

B. The following shall not be waived by the Board, unless there is substantial evidence in the whole record to support a finding that the intent and purpose of the standards will be met in alternative ways:

1. open space requirements in residential areas, except that the Board may waive or reduce open space requirements in the Residential Neighborhood zone. Waivers in compliance with 4.127 (.08) (B)(2)(d).; [Section 4.118 amended by Ord. 806, 7/17/2017]

Response: The project is in the Residential Neighborhood zone, so it qualifies for a waiver or reduction of open space requirements. While the Applicant is not requesting a reduction of open space, the Applicant is requesting a modification to the location of open space in R-5 neighborhood. Please refer to response under WDC Section 4.127(.09).

2. minimum density standards of residential zones. The required minimum density may be reduced by the Board in the Residential Neighborhood zone in compliance with 4.127 (.06) B; [Section 4.118 amended by Ord. 806, 7/17/2017]

Response: The project meets the minimum density standards.

3. minimum landscape, buffering, and screening standards;

Response: The project meets the minimum landscape, buffering, and screening standards.

C. The following shall not be waived by the Board, unless there is substantial evidence in the whole record to support a finding that the intent and purpose of the standards will be met in alternative ways, and the action taken will not violate any applicable federal, state, or regional standards:

1. maximum number of parking spaces;
2. standards for mitigation of trees that are removed;
3. standards for mitigation of wetlands that are filled or damaged; and
4. trails or pathways shown in the Parks and Recreation Master Plan.

Response: The project meets the above standards; no waivers are requested.

(.07) **Density Transfers.** In order to protect significant open space or resource areas, the Development Review Board may authorize the transfer of development densities from one portion of a proposed development to another. Such transfers may go to adjoining properties, provided that those properties are considered to be part of the total development under consideration as a unit.

Response: The applicant is not requesting a density transfer.

-
- (.08) Wetland Mitigation and other mitigation for lost or damaged resources. The Development Review Board may, after considering the testimony of experts in the field, allow for the replacement of resource areas with newly created or enhanced resource areas. The Board may specify the ratio of lost to created and/or enhanced areas after making findings based on information in the record. As much as possible, mitigation areas shall replicate the beneficial values of the lost or damaged resource areas.

Response: The project avoids impacts to the existing onsite wetland, which is not deemed locally significant and is under the jurisdiction of the Oregon Department of State Lands (DSL).

- (.09) Habitat-Friendly Development Practices. To the extent practicable, development and construction activities of any lot shall consider the use of habitat-friendly development practices, which include:
- A. Minimizing grading, removal of native vegetation, disturbance and removal of native soils, and impervious area;
 - B. Minimizing adverse hydrological impacts on water resources, such as using the practices described in Part (a) of Table NR-2 in Section 4.139.03, unless their use is prohibited by an applicable and required state or federal permit, such as a permit required under the federal Clean Water Act, 33 U.S.C. §§1251 et seq., or the federal Safe Drinking Water Act, 42 U.S.C. §§300f et seq., and including conditions or plans required by such permit;
 - C. Minimizing impacts on wildlife corridors and fish passage, such as by using the practices described in Part (b) of Table NR-2 in Section 4.139.03; and
 - D. Using the practices described in Part (c) of Table NR-2 in Section 4.139.03.

Response: This project is designed to minimize impacts to natural habitat through the use of habitat-friendly development practices, including limiting grading to the minimum necessary for installing site improvements and building homes and providing ±3 acres of open space/landscape coverage area, ±1 acre of which is native or undisturbed area. Water, sewer, and stormwater infrastructure was designed and will be installed in accordance with the applicable City requirements in order to minimize adverse impacts on the site and to adjacent properties and surrounding resources. The project preserves 23 existing onsite, line, and offsite trees, including eight Oregon White Oaks along the northwestern boundary of the site.

Section 4.124 STANDARDS APPLYING TO ALL PD RESIDENTIAL ZONES

- (.09) Block and access standards:
- 1. Maximum block perimeter in new land divisions: 1,800 feet.
 - 2. Maximum spacing between streets or private drives for local access: 530 feet, unless waived by the Development Review Board upon finding that barriers such as railroads, freeways, existing buildings, topographic variations, or designated Significant Resource Overlay Zone areas will prevent street extensions meeting this standard. [Amended by Ord. 682, 9/9/10]
 - 3. Maximum block length without pedestrian and bicycle crossing: 330 feet, unless waived by the Development Review Board upon finding that barriers such as railroads, freeways, existing buildings, topographic variations, or designated Significant Resource Overlay Zone areas will prevent pedestrian and bicycle facility extensions meeting this standard. [Section 4.124(.06) amended by Ordinance No. 538, 2/21/02.]

Response: As shown on the Preliminary Plans (Exhibit A), one of the proposed blocks exceeds the maximum block length. A pedestrian pathway is therefore proposed to comply with the mid-block pathways requirement.

Section 4.127 **RESIDENTIAL NEIGHBORHOOD (RN) ZONE.**

(.01) **Purpose.**

The Residential Neighborhood (RN) zone applies to lands within Residential Neighborhood Comprehensive Plan Map designation. The RN zone is a Planned Development zone, subject to applicable Planned Development regulations, except as superseded by this section or in legislative master plans. The purposes of the RN Zone are to:

- A. Implement the Residential Neighborhood policies and implementation measures of the Comprehensive Plan.
- B. Implement legislative master plans for areas within the Residential Neighborhood Comprehensive Plan Map designation.
- C. Create attractive and connected neighborhoods in Wilsonville.
- D. Regulate and coordinate development to result in cohesive neighborhoods that include: walkable and active streets; a variety of housing appropriate to each neighborhood; connected paths and open spaces; parks and other non-residential uses that are focal points for the community; and, connections to and integration with the larger Wilsonville community.
- E. Encourage and require quality architectural and community design as defined by the Comprehensive Plan and applicable legislative master plans.
- F. Provide transportation choices, including active transportation options.
- G. Preserve and enhance natural resources so that they are an asset to the neighborhoods, and there is visual and physical access to nature.

Response: Per Figure 5 of the Frog Pond West Master Plan (below), the Frog Pond Crossing site is located within the RN Comprehensive Plan Map designation and is subject to these provisions and to applicable Planned Development (PD) regulations.

Frog Pond West Master Plan Figure 5: Comprehensive Plan Designations

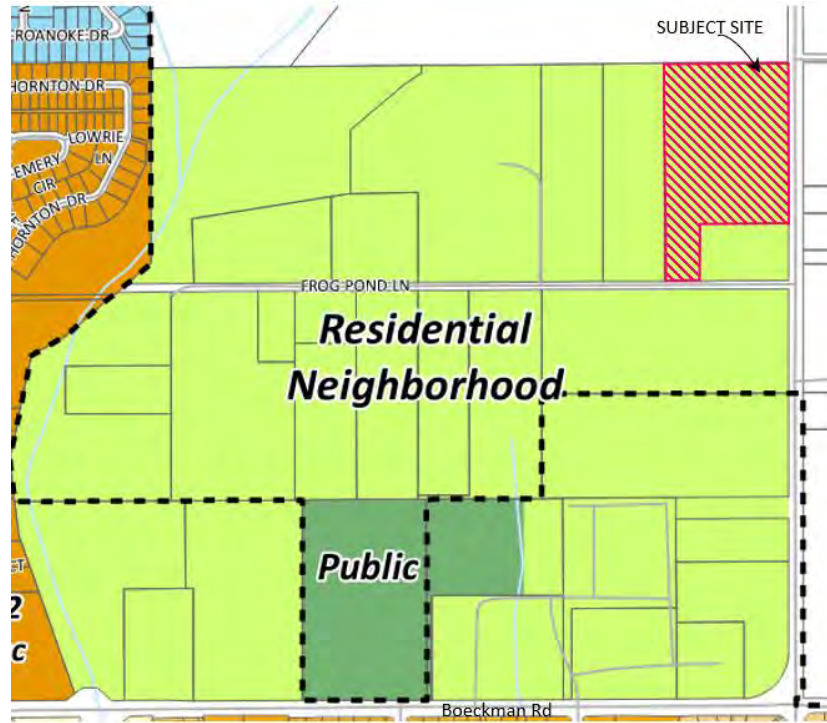

(.02) Permitted uses:

- A. Open Space.
- B. Single-Family Dwelling Unit.
- C. Attached Single-Family Dwelling Unit. In the Frog Pond West Neighborhood, a maximum of 2 dwelling units, not including ADU's, may be attached.
- D. Duplex.
- E. Multiple-Family Dwelling Units, except when not permitted in a legislative master plan, subject to the density standards of the zone. Multi-family dwelling units are not permitted within the Frog Pond West Master Plan area.
- F. Cohousing.
- G. Cluster Housing.
- H. Public or private parks, playgrounds, recreational and community buildings and grounds, tennis courts, and similar recreational uses, all of a non-commercial nature, provided that any principal building or public swimming pool shall be located not less than forty-five (45) feet from any other lot.
- I. Manufactured homes.

Response: The project includes 29 single-family lots with associated open space, which are permitted uses in the RN zone.

(.05) Residential Neighborhood Zone Sub-districts:

- A. RN Zone sub-districts may be established to provide area-specific regulations that implement legislative master plans.

1. For the Frog Pond West Neighborhood, the sub-districts are listed in Table 1 of this code and mapped on Figure 6 of the Frog Pond West Master Plan. The Frog Pond West Master Plan Sub-District Map serves as the official sub-district map for the Frog Pond West Neighborhood.

Response: Approximately 7.4 acres of the project site are within Subdistrict 11, which is designated Medium Lot Single Family (R-7), and approximately 0.8 acres of the site lies within the Subdistrict 10, which is designated Small Lot Single Family (R5).

Frog Pond West Master Plan Figure 6: Frog Pond West Land Use and Subdistricts

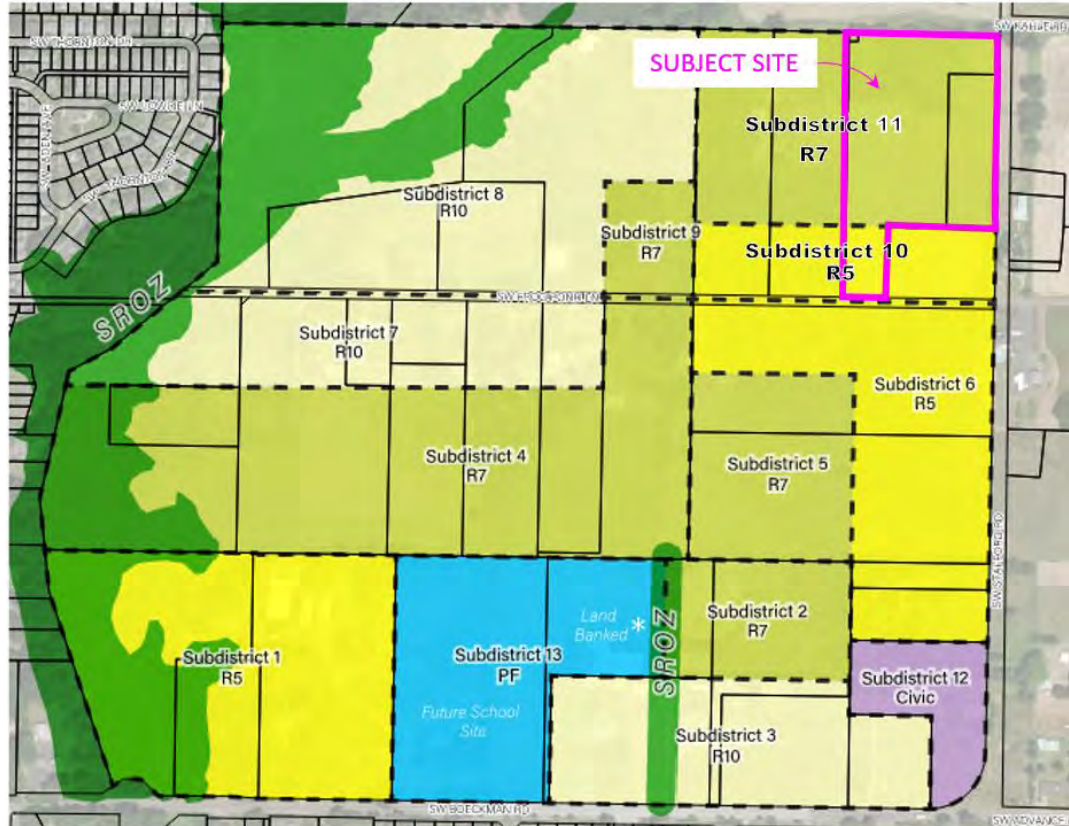

(.06) Minimum and Maximum Residential Units:

- A. The minimum and maximum number of residential units approved shall be consistent with this code and applicable provisions of an approved legislative master plan.
 1. For the Frog Pond West Neighborhood, Table 1 in this code and Frog Pond West Master Plan Table 1 establish the minimum and maximum number of residential units for the subdistricts.
 2. For parcels or areas that are a portion of a sub-district, the minimum and maximum number of residential units are established by determining the proportional gross acreage and applying that proportion to the minimums and maximums listed in Table 1. The maximum density on a parcel may be increased, up to a maximum of 10% of what would otherwise be permitted, based on an adjustment to an SROZ boundary that is consistent with 4.139.06.

Response: The following table summarizes how the proposed residential units in each subdistrict are consistent with the density range allowed by the Frog Pond West Master Plan.

The City of Wilsonville Development Code defines “gross development area” as the total area after subtracting out (1) land area within the City’s Significant Resource Overlay Zone and (2) land area encumbered by a Bonneville Power Administration power line easement. The established density range for Subdistrict 10 is 30 to 38 units. Gross project area encompasses approximately 14 percent of Subdistrict 10. Accordingly, the proportional share of units allowed to be built on the project site is four to five units, based on the percentage of the site within the subdistrict. The project proposes five lots, which is the maximum number allowed.

The established density range for Subdistrict 11 is 46 to 58 units. The gross project area encompasses approximately 41 percent of Subdistrict 10. The proportional share of units allowed on the project site is 19 to 24 units. The project proposes 24 lots, which is the maximum number allowed.

Table 1. Proposed Residential Units

Subdistrict	Gross Subdistrict Area (acres), after subtracting out BPA easement	Gross Site Area (acres), after subtracting out BPA easement	Site % of Gross Subdistrict	Established Dwelling Unit Range for Subdistrict	Proportional Dwelling Unit Range for Site	Proposed Dwelling Units
10 – R-5	6.0	0.8	14%	30-38	4 – 5	5
11 – R-7	12.7	5.2	41%	46-58	19 – 24	24

- B. The City may allow a reduction in the minimum density for a sub-district when it is demonstrated that the reduction is necessary due to topography, protection of trees, wetlands and other natural resources, constraints posed by existing development, infrastructure needs, provision of nonresidential uses and similar physical conditions.

Response: The applicant is not requesting a reduction in minimum density.

(.07) **Development Standards Generally**

- A. Unless otherwise specified by this the regulations in this Residential Development Zone chapter, all development must comply with Section 4.113, Standards Applying to Residential Development in Any Zone.

Response: Compliance with applicable regulations of Section 4.113 is addressed earlier in the narrative. Some regulations of 4.127 supersede the regulations of 4.113.

(.08) **Lot Development Standards:**

- A. Lot development shall be consistent with this code and applicable provisions of an approved legislative master plan.

- B. Lot Standards Generally. For the Frog Pond West Neighborhood, Table 2 establishes the lot development standards unless superseded or supplemented by other provisions of the Development Code.
- C. Lot Standards for Small Lot Sub-districts. The purpose of these standards is to ensure that development in the Small Lot Sub-districts includes varied design that avoids homogenous street frontages, creates active pedestrian street frontages and has open space that is integrated into the development pattern.
- D. Standards. Planned developments in the Small Lot Sub-districts shall include one or more of the following elements on each block:
 1. Alleys.
 2. Residential main entries grouped around a common green or entry courtyard (e.g. cluster housing).
 3. Four or more residential main entries facing a pedestrian connection allowed by an applicable legislative master plan.
 4. Garages recessed at least 4 feet from the front façade or 6 feet from the front of a front porch.

Neighborhood Zone SubDistrict	Min. Lot Size (sq.ft.)	Min. Lot Depth (ft.)	Max. Lot Coverage (%)	Min. Lot Width G, H, J (ft.)	Max. Bldg. Height F (ft.)	Setbacks ^H				
						Front Min. (ft.)	Rear Min. (ft.)	Side Min. (note)	Garage Min Setback from Alley (ft.)	Garage Min Setback from Street ^K (ft.)
R-7 Medium Lot Single Family	6,000 ^A	60'	45% ^B	35	35	15 ^C	15	I	18 ^D	20
R-5 Small Lot Single Family	4,000 ^A	60'		35	35		15	I	18 ^D	20

Notes:

- A May be reduced to 80% of minimum lot size where necessary to preserve natural resources (e.g. trees, wetlands) and/or provide active open space. Cluster housing may be reduced to 80% of minimum lot size. Duplexes in the R-5 Sub-District have a 6,000 SF minimum lot size.*
- B On lots where detached accessory buildings are built, maximum lot coverage may be increased by 10%.*
- C Front porches may extend 5 feet into the front setback.*
- D The garage setback from alley shall be minimum of 18 feet to a garage door facing the alley in order to provide a parking apron. Otherwise, the rear or side setback requirements apply.*
- F Vertical encroachments are allowed up to ten additional feet, for up to 10% of the building footprint; vertical encroachments shall not be habitable space.*
- G May be reduced to 24' when the lot fronts a cul-de-sac. No street frontage is required when the lot fronts on an approved, platted private drive or a public pedestrian access in a cluster housing development.*
- H Front Setback is measured as the offset of the front lot line or a vehicular or pedestrian access easement line. On lots with alleys, Rear Setback shall be measured from the rear lot line abutting the alley.*
- I On lots greater than 10,000 SF with frontage 70 ft. or wider, the minimum combined side yard setbacks shall total 20 ft. with a minimum of 10 ft. On other lots, minimum side setback shall be 5 ft. On a corner lot, minimum side setbacks are 10 feet.*

J For cluster housing with lots arranged on a courtyard, frontage shall be measured at the front door face of the building adjacent to a public right of way or a public pedestrian access easement linking the courtyard with the Public Way.

K Duplexes with front-loaded garages are limited to one shared standard-sized driveway/apron.

Response: WDC Section 4.127, Table 2 (above) establishes the lot development standards for the Frog Pond West neighborhood. These standards supersede the setback standards of 4.113(.03). The table below demonstrates that the proposed project meets the lot dimensional standards, which are applied at the time of subdivision approval.

The Applicant is requesting a reduction in the minimum lot size for four lots within Subdistrict 11 (Lots 6, 7, 15 and 16) to accommodate preservation of three mature Oregon White Oaks in the northwestern portion of the site (tree # 20128 – 55” DBH, tree # 20125 – 34” DBH, and tree # 20124 – 36” DBH). A reduction up to 80% in lot size is allowed by Code for tree preservation. In order to preserve those mature trees, Trillium Street needs to run to the south of the tree grove, which reduces the land area in the middle block, between Trillium Street and Windflower Street. Although not directly in the path of the trees that are being preserved, reduction of lot sizes of Lots 6, 7, 15 and 16 enables the street realignment such that it avoids impact to natural resources. The code allows a reduction up to 4,800 square feet. The project proposes a reduction between 5,000 square feet and 5,074 square feet. As a result, the proposed lots in Subdistrict 11/R7 will range between ±5,000 and ±6,600 square feet.

The Applicant initially studied an alternative site layout with a public street connection as envisioned by the Street Demonstrated Plan (Figure 1 below), but that alternative would generate adverse impacts to natural resources. That layout was submitted to City staff for review prior to the preapplication conference. As shown on Figure 1, an alternative site layout meeting minimum lot sizes would require the removal of three mature oak trees, which the proposed layout manages to preserve. Therefore, the Applicant has selected the environmentally superior site layout.

Figure 1: Alternative Street Layout from Preapplication Meeting



Note G of Table 2, above, allows lots not to have street frontage when they front on a public pedestrian access in a cluster housing development. Although not a cluster development, the proposed project is a PUD, which encourages flexibility in location and design of the neighborhood with the intent of preserving existing landscape features and natural resources and better integrating them into site design. By using common open

space area with pedestrian pathway as lot frontage for eight lots, the project can accommodate preservation of an existing grove of mature Oregon White Oaks. The Frog Pond West Master Plan prioritizes preservation of existing trees and encourages site design that maximizes front-yard orientation to natural areas and provides enhanced elevations adjacent to publicly accessible open space. As shown on the Preliminary Subdivision Plan (Exhibit A), lots 17 – 24 have legal access via a private alley (Tract B). Front lot lines meet the 35-foot minimum width and abut natural resource areas. Lots 17-21 overlook an oak tree grove, and lots 22-24 face the wetland, a valuable open space for wildlife and the resident’s aesthetic enjoyment. The City can make a finding that the waiver of street frontage will result in greater public benefit gained from natural resource conservation and higher quality of the community than strict adherence to the code.

Site development standards, including lot coverage, setbacks, and heights, will be reviewed at the time of building permit approval. The preliminary conceptual building elevations included in Exhibit M demonstrate that setback and lot coverage standards can be met.

Table 2. Compliance with Neighborhood Zone Lot Development Standards

Standard	R-7 Designation		R-5 Designation	
	Required	Proposed	Required	Proposed
Lot Size	6,000 square feet 4,800 square feet using 80% reduction ^A	6,000 square feet 4,842 – 5,044 square feet for four reduced lots	4,000 square feet ^A	4,039 square feet
Lot Depth	60 feet	91 feet	60 feet	97 feet
Lot Width	35 feet	55 feet	35 feet	41.50 feet
Front Setback	15 feet	15 feet	12 feet	12 feet
Rear Setback	15 feet	15 feet	15 feet	15 feet
Side Setback – Interior	5 feet	5 feet	5 feet	5 feet
Side Setback – Corner Lot	10 feet	10 feet	10 feet	10 feet
Garage Setback from street	20 feet	20 feet	20 feet	20 feet
Garage Setback from Alley	18 feet	18 feet	18 feet	18 feet
^A May be reduced to 80% of minimum lot size where necessary to preserve natural resources (e.g. trees, wetlands) and/or provide active open space, per WDC 4.127 Table 2, Note A.				

- D. Lot Standards Specific to the Frog Pond West Neighborhood.
 - 1. Lots adjacent to Boeckman Road and Stafford Road shall meet the following standards:
 - a. Rear or side yards adjacent to Boeckman Road and Stafford Road shall provide a wall and landscaping consistent with

the standards in Figure 10 of the Frog Pond West Master Plan.

Response: Five lots (Lots 25-29) are adjacent to Stafford Road. As shown the Preliminary Subdivision Plan, the rear yards provide a wall that is consistent with the design required in Figure 10 of the Frog Pond Master Plan. The Preliminary Frontage Buffer Landscape Plan shows low shrubs and ornamental plants at the base of the wall and in the planted buffer area.

The property to the north of Lot 25 is within the BPA transmission easement, which does not allow vertical structures. Additionally, as shown on the Preliminary Existing Condition Plan and Preliminary Grading Plan, and as described in detail in the Natural Resource Assessment (Exhibit F), a 1.48-acre wetland is located in the northeastern corner of the project site to the north of future Lot 25. The wetland extends all the way to property line, including within the proposed dedicated right-of-way. Therefore, instead of the split-rail fence, the applicant proposes vegetative buffer to serve as screening along the open space portion of SW Frontage Road frontage.

2. Lots adjacent to the collector-designated portions of Willow Creek Drive and Frog Pond Lane shall not have driveways accessing lots from these streets, unless no practical alternative exists for access. Lots in Large Lot Sub-districts are exempt from this standard.

Response: The site includes a portion of Collector-designated Frog Pond Lane. No driveways are proposed to access the lots from that street.

(.09) Open Space:

A. Purpose. The purposes of these standards for the Residential Neighborhood Zone are to:

1. Provide light, air, open space, and useable recreation facilities to occupants of each residential development.
2. Retain and incorporate natural resources and trees as part of developments.
3. Provide access and connections to trails and adjacent open space areas.

For Neighborhood Zones which are subject to adopted legislative master plans, the standards work in combination with, and as a supplement to, the park and open space recommendations of those legislative master plans. These standards supersede the Outdoor Recreational Area requirements in WC Section 4.113 (.01).

B. Within the Frog Pond West Neighborhood, the following standards apply:

1. Properties within the R-10 Large Lot Single Family sub-districts and R-7 Medium Lot Single Family sub-districts are exempt from the requirements of this section. If the Development Review Board finds, based upon substantial evidence in the record, that there is a need for open space, they may waive this exemption and require open space proportional to the need.
2. For properties within the R-5 Small Lot Single Family sub-districts, Open Space Area shall be provided in the following manner:
 - a. Ten percent (10%) of the net developable area shall be in open space. Net developable area does not include land for

non-residential uses, SROZ-regulated lands, streets and private drives, alleys and pedestrian connections. Open space must include at least 50% usable open space as defined by this Code and other like space that the Development Review Board finds will meet the purpose of this section.

Response: The proposed project includes properties within R-7 Medium Lot Single Family designation, which is exempt from the Open Space requirements, and ± 0.5 net acres in R-5 Small Lot Single Family designation, which requires 0.05 acres (or approximately 2,089 square feet) of open space. As shown in Table 3, below, the Frog Pond Crossing project exceeds the requirement and provides ±3 acres of open space, ±1 acre of which is comprised of native landscaping or undisturbed area. However, only a small portion of the overall project site (0.5 net acres) lies within the R-5-designated area, and one third of the land area within R-5 designation is dedicated as Marigold Terrace right-of-way, which serves as a single point of access to Frog Pond Crossing. Due to the site constraints, the applicant is requesting to satisfy the project’s R-5 open space requirement by providing a large, uninterrupted open space area in the northeast corner of the neighborhood, within a short walking distance from R-5. This site design balances the applicant’s ability to develop the R-5-designated area at the density and lot dimensional standards allowed by the code, as well as provide a higher quality uninterrupted usable open space for the residents of the community.

Table 3. Required Open Space

R-5 Net Developable Site Area (square feet)	Open Space		Usable Open Space	
	Required (square feet)	Provided (square feet)	Required (square feet)	Provided (square feet)
20,892	2,089	109,344*	1,045	57,846**

* Open Space area includes open space within Tract A, excluding the stormwater detention pond.

** Usable Open Space area includes open space within Tract A, excluding the stormwater detention pond and wetland.

- b. Natural resource areas such as tree groves and/or wetlands, and unfenced low impact development storm water management facilities, may be counted toward the 10% requirement at the discretion of the Development Review Board. Fenced storm water detention facilities do not count toward the open space requirement. Pedestrian connections may also be counted toward the 10% requirement.

Response: The area comprised of the existing wetland and pedestrian trails within Open Space Tract A measures ±2.5 acres in size. The area calculation does not include the stormwater facility located in the tract. Storm water detention pond is not included in the open space area calculations.

- c. The minimum land area for an individual open space is 2,000 square feet, unless the Development Review Board finds, based on substantial evidence in the record, that a smaller minimum area adequately fulfills the purpose of this Open Space standard.

Response: There are two qualifying open space tracts. Open Space Tract A contains ±109,344 square feet of open space, not including the stormwater detention pond. Open Space Tract C is ±3,270 square feet in size.

- d. The Development Review Board may reduce or waive the usable open space requirement in accordance with Section 4.118(.03). The Board shall consider substantial evidence regarding the following factors: the walking distance to usable open space adjacent to the subject property or within 500 feet of it; the amount and type of open space available adjacent or within 500 feet of the subject property, including facilities which support creative play.

Response: No reduction to open space requirements is requested. This standard is not applicable.

- e. The Development Review Board may specify the method of assuring the long-term protection and maintenance of open space and/or recreational areas. Where such protection or maintenance are the responsibility of a private party or homeowners' association, the City Attorney shall review any pertinent bylaws, covenants or agreements prior to recordation.

Response: Open space and recreational areas will be owned and maintained by the HOA. Pertinent bylaws, covenants, and agreements will be provided to the City prior to plat recordation.

(.10) Block, access and connectivity standards:

- A. Purpose. These standards are intended to regulate and guide development to create: a cohesive and connected pattern of streets, pedestrian connections and bicycle routes; safe, direct and convenient routes to schools and other community destinations; and, neighborhoods that support active transportation and Safe Routes to Schools.
- B. Blocks, access and connectivity shall comply with adopted legislative master plans.
 - 1. Within the Frog Pond West Neighborhood, streets shall be consistent with Figure 18, Street Demonstration Plan, in the Frog Pond West Master Plan. The Street Demonstration Plan is intended to be guiding, not binding. Variations from the Street Demonstration Plan may be approved by the Development Review Board, upon finding that one or more of the following justify the variation: barriers such as existing buildings and topography; designated Significant Resource Overlay Zone areas; tree groves, wetlands or other natural resources; existing or planned parks and other active open space that will serve as pedestrian connections for the public; alignment with property lines and ownerships that result in efficient use of land while providing substantially equivalent connectivity for the public; and/or site design that provides substantially equivalent connectivity for the public.

Response: The proposed streets are generally consistent with the Frog Pond Master Plan. As shown on Figure 18, Street Demonstration Plan envisions a grid street plan and three pedestrian connections within the project site. This plan is merely a “guideline” pursuant to WDC Section 4.127(.10)(A). The proposed street network generally follows the pattern intended by the Master Plan with some minor modifications. The project intends to preserve the mature Oak tree grove in the northwestern portion of Tax Lot 300. In order

the avoid impact to the trees, the size of the middle block needs to be reduced so that Trillium Street can be moved to the south.

As shown on the figure below, the Applicant proposes to substitute public street connection (Marigold Terrace) through the middle block with a pedestrian crossing, which will align with the pedestrian trail to the north. The project will construct two-thirds of the full pedestrian connection width in Tract C. The remaining width will be accommodated with the future development of the adjacent Tax Lot 401, as the tree preservation achieved through this layout benefits both properties.

The pedestrian connection from Windflower Street to Stafford Road in the eastern portion of the site will be provided by the developer of Tax Lot 200, where it aligns with the southern sidewalk on Windflower Street, also to be constructed by that developer concurrently with the pedestrian connection. This configuration allows for pedestrians to travel without crossing a street.

Please refer to the Preliminary Street Plan in Exhibit A, which illustrates the proposed blocks, access, and connectivity for Frog Pond Crossing project. The modified grid pattern provides efficient vehicular and pedestrian connections through the project and to SW Stafford Road. The City can make a finding that the proposed subdivision street plan provides for a substantially equivalent level of pedestrian connectivity. Further, the proposed street connection does not require out-of-direction pedestrian travel and does not result in greater distances for pedestrian access to the proposed subdivision from SW Stafford Road than would otherwise be the case if the Street Demonstration Plan were adhered to.

Comparison of Frog Pond Master Plan Figure 18: Street Demonstration Plan & Proposed Connections

Master Plan Concept:



Proposed Project:

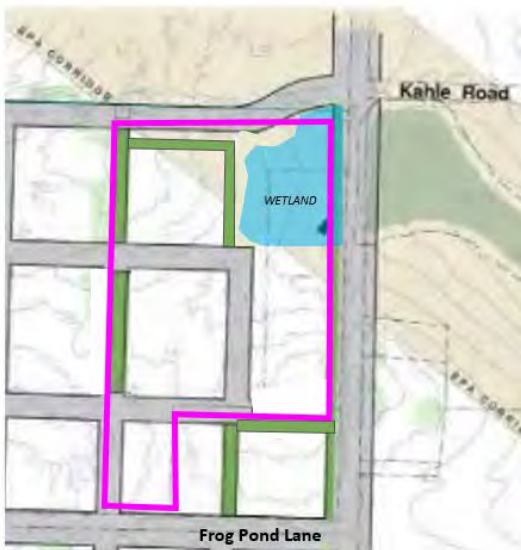

(.11) Signs. Per the requirements of Sections 4.156.01 through 4.156.11 and applicable provisions from adopted legislative master plans.

Response: Compliance with Sections 4.156.01 through 4.156.11 is addressed further in the narrative.

(.12) Parking. Per the requirements of Section 4.155 and applicable provisions from adopted legislative master plans.

Response: Project meets parking code requirements. Compliance with Section 4.155 is addressed further in the narrative.

(.13) Corner Vision Clearance. Per the requirements of Section 4.177.

Response: Compliance with Section 4.177 is addressed further in the narrative.

(.14) Main Entrance Standards

(.15) Garage Standards

(.16) Residential Design Standards

Response: The design of individual homes will be reviewed at the time of building permit submittal. The application includes conceptual building elevations demonstrate that the standards of subsections 4.127(.14), (.15), and (.16) can be met.

(0.17) Fences

A. Within Frog Pond West, fences shall comply with standards in 4.113 (.08) except as follows:

1. Columns for the brick wall along Boeckman Road and Stafford Road shall be placed at lot corners where possible.
2. A solid fence taller than 4 feet in height is not permitted within 8 feet of the brick wall along Boeckman Road and Stafford Road, except for fences placed on the side lot line that are perpendicular to the brick wall and end at a column of the brick wall.
3. Height transitions for fences shall occur at fence posts.

Response: As shown on the preliminary plans (Exhibit A), Tract A and Tract D are located along Stafford Road. A brick wall is proposed along Tract D, which serves as a landscape buffer/PUE along the residential lots with frontage on Stafford Road. Please refer to the Preliminary Frontage Wall Details sheet in the preliminary plans. The proposed wall design includes columns at regular intervals along Stafford Road. Tract A contains a wetland extending onto Stafford Road right-of-way dedication portion of the property, and it is located within BPA easement, which prohibits vertical improvements within its limits, therefore, the project does not include a fence along Tract A. However, a dense blackberry thicket with spiny stems is present along the edge of the wetland on Stafford Road. The project preserves the existing landscaping within the wetland, which will continue to serve as a natural vegetative barrier, essentially performing the same function as a fence would.

(0.18) Homes Adjacent to Schools, Parks and Public Open Spaces

A. Purpose. The purpose of these standards is to ensure that development adjacent to schools and parks is designed to enhance those public spaces with

quality design that emphasizes active and safe use by people and is not dominated by driveways, fences, garages, and parking.

- B. Applicability. These standards apply to development that is adjacent to or faces schools and parks. As used here, the term adjacent includes development that is across a street or pedestrian connection from a school or park.
- C. Development must utilize one or more of the following design elements:
 - 1. Alley loaded garage access.
 - 2. On corner lots, placement of the garage and driveway on the side street that does not face the school, park, or public open space.
 - 3. Recess of the garage a minimum of four feet from the front façade of the home. A second story above the garage, with windows, is encouraged for this option.
- D. Development must be oriented so that the fronts or sides of homes face adjacent schools or parks. Rear yards and rear fences may generally not face the schools or parks, unless approved through the waiver process of 4.118 upon a finding that there is no practicable alternative due to the size, shape or other physical constraint of the subject property.

Response: The proposed project is not adjacent to any schools, parks, or public open spaces.

Section 4.139 SIGNIFICANT RESOURCE OVERLAY ZONE (SROZ) ORDINANCE

Response: The proposed project is not within an SROZ. The applicant has completed a delineation of the wetland which is present on site and has determined that it does not meet the criteria to be added to the SROZ map. As indicated in the Natural Resource Assessment attached as Exhibit F, the applicant concurs with the accuracy of the SROZ map of the subject property. The wetland is likely to be determined jurisdictional to the Oregon Department of State Lands (DSL). The wetland delineation report is currently under review by DSL.

Section 4.140 PLANNED DEVELOPMENT REGULATIONS

(.02) Lot Qualification.

- A. Planned Development may be established on lots which are suitable for and of a size to be planned and developed in a manner consistent with the purposes and objectives of Section 4.140.
- B. Any site designated for development in the Comprehensive Plan may be developed as a Planned Development, provided that it is zoned "PD." All sites which are greater than two (2) acres in size, and designated in the Comprehensive Plan for commercial, residential, or industrial use shall be developed as Planned Developments, unless approved for other uses permitted by the Development Code. Smaller sites may also be developed through the City's PD procedures, provided that the location, size, lot configuration, topography, open space and natural vegetation of the site warrant such development.

Response: The subject site is ±8.45 acres and is suitable for Planned Development. The project accommodates 29 single-family lots, provides an efficient circulation system, connects to the regional trail network via Stafford trail, and provides active and passive open space consistent with the purpose of Section 4.140. The application requests to rezone the property to RN (Residential Neighborhood). Pursuant to the Frog Pond West Master plan,

development in the RN zone follows the same planned development procedure as Planned Development (PD) zones.

(.03) **Ownership.**

- A. The tract or tracts of land included in a proposed Planned Development must be in one (1) ownership or control or the subject of a joint application by the owners of all the property included. The holder of a written option to purchase, with written authorization by the owner to make applications, shall be deemed the owner of such land for the purposes of Section 4.140.
- B. Unless otherwise provided as a condition for approval of a Planned Development permit, the permittee may divide and transfer units or parcels of any development. The transferee shall use and maintain each such unit or parcel in strict conformance with the approval permit and development plan.

Response: The proposed project consists of three lots, all of which are under one ownership. The land use application has been signed by the property owners.

(.04) **Professional Design.**

- A. The applicant for all proposed Planned Developments shall certify that the professional services of the appropriate professionals have been utilized in the planning process for development.
- B. Appropriate professionals shall include, but not be limited to the following to provide the elements of the planning process set out in Section 4.139:
 - 1. An architect licensed by the State of Oregon;
 - 2. A landscape architect registered by the State of Oregon;
 - 3. An urban planner holding full membership in the American Institute of Certified Planners, or a professional planner with prior experience representing clients before the Development Review Board, Planning Commission, or City Council; or
 - 4. A registered engineer or a land surveyor licensed by the State of Oregon.
- C. One of the professional consultants chosen by the applicant from either 1, 2, or 3, above, shall be designated to be responsible for conferring with the planning staff with respect to the concept and details of the plan.
- D. The selection of the professional coordinator of the design team will not limit the owner or the developer in consulting with the planning staff.

Response: Mimi Doukas, AICP, RLA, of AKS Engineering & Forestry, is the coordinator of a professional design team, which includes a registered civil engineer, a land surveyor, and a landscape architect all licensed in the State of Oregon.

(.05) **Planned Development Permit Process.**

- A. All parcels of land exceeding two (2) acres in size that are to be used for residential, commercial or industrial development, shall, prior to the issuance of any building permit:
 - 1. Be zoned for planned development;
 - 2. Obtain a planned development permit; and
 - 3. Obtain Development Review Board, or, on appeal, City Council approval.

Response: The subject site exceeds 2 acres in size and is proposed for residential development. This application includes a Zoning Map Amendment to apply the RN zone to the site; Planned Development Stage I application; and Planned Development Stage II application.

B. Zone change and amendment to the zoning map are governed by the applicable provisions of the Zoning Sections, inclusive of Section 4.197.

Response: The requested Zoning Map Amendment is subject to the applicable provisions of the Zoning Sections and 4.197. These provisions are addressed further in the narrative.

C. Development Review Board approval is governed by Sections 4.400 to 4.450

D. All planned developments require a planned development permit. The planned development permit review and approval process consists of the following multiple stages, the last two or three of which can be combined at the request of the applicant:

1. Pre-application conference with Planning Department;
2. Preliminary (Stage I) review by the Development Review Board. When a zone change is necessary, application for such change shall be made simultaneously with an application for preliminary approval to the Board; and
3. Final (Stage II) review by the Development Review Board
4. In the case of a zone change and zone boundary amendment, City Council approval is required to authorize a Stage I preliminary plan.

Response: A pre-application conference was held with the Planning Department on December 12, 2019. Concurrent Zoning Map Amendment, and Stage I and Stage II Planned Development permit applications (and a number of additional concurrent applications) have been submitted for review by the Development Review Board.

[...]

(.07) Preliminary Approval (Stage One):

A. Applications for preliminary approval for planned developments shall:

1. Be made by the owner of all affected property or the owner's authorized agent; and
2. Be filed on a form prescribed by the City Planning Department and filed with said Department.
3. Set forth the professional coordinator and professional design team as provided in subsection (.04), above.
4. State whether the development will include mixed land uses, and if so, what uses and in what proportions and locations.

Response: This submittal includes all of the above information.

B. The application shall include conceptual and quantitatively accurate representations of the entire development sufficient to judge the scope, size, and impact of the development on the community; and, in addition to the requirements set forth in Section 4.035, shall be accompanied by the following information:

1. A boundary survey or a certified boundary description by a registered engineer or licensed surveyor.

-
2. Topographic information as set forth in Section 4.035
 3. A tabulation of the land area to be devoted to various uses, and a calculation of the average residential density per net acre.
 4. A stage development schedule demonstrating that the developer intends receive Stage II approval within two (2) years of receiving Stage I approval, and to commence construction within two (2) years after the approval of the final development plan, and will proceed diligently to completion; unless a phased development schedule has been approved; in which case adherence to that schedule shall be considered to constitute diligent pursuit of project completion.
 5. A commitment by the applicant to provide in the Final Approval (Stage II) a performance bond or other acceptable security for the capital improvements required by the project.
 6. If it is proposed that the final development plan will be executed in stages, a schedule thereof shall be provided.
 7. Statement of anticipated waivers from any of the applicable site development standards.

Response: A boundary survey including topographic information is provided in the Preliminary Existing Conditions Plan (Exhibit A). A tabulation of land area and residential density is included in Table 1 within this narrative. Stage I and Stage II approvals are being requested concurrently, and a stage development schedule is not proposed.

[...]

(.09) Final Approval (Stage Two):

[Note: Outline Number is incorrect.]

- A. Unless an extension has been granted by the Development Review Board, within two (2) years after the approval or modified approval of a preliminary development plan (Stage I), the applicant shall file with the City Planning Department a final plan for the entire development or when submission in stages has been authorized pursuant to Section 4.035 for the first unit of the development, a public hearing shall be held on each such application as provided in Section 4.013.

Response: A Stage II application has been submitted concurrently with the Stage I application.

- B. After such hearing, the Development Review Board shall determine whether the proposal conforms to the permit criteria set forth in this Code, and shall approve, conditionally approve, or disapprove the application.
- C. The final plan shall conform in all major respects with the approved preliminary development plan, and shall include all information included in the preliminary plan plus the following:
 1. The location of water, sewerage and drainage facilities;
 2. Preliminary building and landscaping plans and elevations, sufficient to indicate the general character of the development;
 3. The general type and location of signs;
 4. Topographic information as set forth in Section 4.035;
 5. A map indicating the types and locations of all proposed uses; and
 6. A grading plan.

Response: The required information is included as follows in the Frog Pond Crossing PUD Preliminary Plans (Exhibit A):

1. Preliminary Composite Utility Plan
2. Preliminary Landscape Plan
3. Preliminary Grading and Erosion Control Measures

Preliminary conceptual building elevations are included as Exhibit M. Sign locations and permits will be provided under separate application.

- D. The final plan shall be sufficiently detailed to indicate fully the ultimate operation and appearance of the development or phase of development. However, Site Design Review is a separate and more detailed review of proposed design features, subject to the standards of Section 4.400.

Response: A concurrent Site Design Review of Open Space application has been submitted. Section 4.400 Site Design Review criteria are addressed in the narrative.

- E. Copies of legal documents required by the Development Review Board for dedication or reservation of public facilities, or for the creation of a non-profit homeowner's association, shall also be submitted.

Response: Draft covenants, conditions & restrictions (CC&Rs) are included as Exhibit I.

[...]

- J. A planned development permit may be granted by the Development Review Board only if it is found that the development conforms to all the following criteria, as well as to the Planned Development Regulations in Section 4.140:

1. The location, design, size and uses, both separately and as a whole, are consistent with the Comprehensive Plan, and with any other applicable plan, development map or Ordinance adopted by the City Council.

Response: The site is located within the Frog Pond West master planned area of the Frog Pond community. The Frog Pond West Master Plan has been incorporated into the Comprehensive Plan and designates the site for single-family residential use. Consistency with the Comprehensive Plan is addressed earlier in the narrative. The RN zone is identified as the implementing zone for the Residential Neighborhood (RN) Comprehensive Plan designation; this zone requires that all development within it be approved as a Planned Development.

2. That the location, design, size and uses are such that traffic generated by the development at the most probable used intersection(s) can be accommodated safely and without congestion in excess of Level of Service D, as defined in the Highway Capacity Manual published by the National Highway Research Board, on existing or immediately planned arterial or collector streets and will, in the case of commercial or industrial developments, avoid traversing local streets. Immediately planned arterial and collector streets are those listed in the City's adopted Capital Improvement Program, for which funding has been approved or committed, and that are scheduled for completion within two years of occupancy of the development or four year if they are an associated crossing, interchange, or approach street improvement to Interstate 5.

-
- a. In determining levels of Service D, the City shall hire a traffic engineer at the applicant's expense who shall prepare a written report containing the following minimum information for consideration by the Development Review Board:
 - i. An estimate of the amount of traffic generated by the proposed development, the likely routes of travel of the estimated generated traffic, and the source(s) of information of the estimate of the traffic generated and the likely routes of travel; [Added by Ord. 561, adopted 12/15/03.]
 - ii. What impact the estimate generated traffic will have on existing level of service including traffic generated by (1) the development itself, (2) all existing developments, (3) Stage II developments approved but not yet built, and (4) all developments that have vested traffic generation rights under section 4.140(.10), through the most probable used intersection(s), including state and county intersections, at the time of peak level of traffic. This analysis shall be conducted for each direction of travel if backup from other intersections will interfere with intersection operations. [Amended by Ord 561, adopted 12/15/03.]
 - b. The following are exempt from meeting the Level of Service D criteria standard:
 - i. A planned development or expansion thereof which generates three (3) new p.m. peak hour traffic trips or less;
 - ii. A planned development or expansion thereof which provides an essential governmental service.
 - c. Traffic generated by development exempted under this subsection on or after Ordinance No. 463 was enacted shall not be counted in determining levels of service for any future applicant. [Added by Ord 561, adopted 12/15/03.]
 - d. Exemptions under 'b' of this subsection shall not exempt the development or expansion from payment of system development charges or other applicable regulations. [Added by Ord 561, adopted 12/15/03.]
 - e. In no case will development be permitted that creates an aggregate level of traffic at LOS "F". ([Added by Ord 561, adopted 12/15/03.]

Response: DKS and Associates has conducted a Transportation Impact Study (TIS) to evaluate traffic impacts from the proposed project. It addresses the provisions above. Please refer to TIS for additional detail demonstrating that the project meets the above criteria.

3. That the location, design, size and uses are such that the residents or establishments to be accommodated will be adequately served by existing or immediately planned facilities and services.

Response: The site will be adequately served by public facilities and services, including utilities. The project will construct transportation infrastructure with site development and will

dedicate 12 feet of public right-of-way width to Stafford Road for the future widening and improvement.

[...]

(.10) Early Vesting of Traffic Generation. [...]

Response: No early vesting of traffic generation is requested. This standard is not applicable.

CHAPTER 4. GENERAL DEVELOPMENT REGULATIONS

Section 4.154 ON-SITE PEDESTRIAN ACCESS AND CIRCULATION

(.01) On-site Pedestrian Access and Circulation

A. The purpose of this section is to implement the pedestrian access and connectivity policies of the Transportation System Plan. It is intended to provide for safe, reasonably direct, and convenient pedestrian access and circulation.

B. Standards. Development shall conform to all of the following standards:

1. Continuous Pathway System. A pedestrian pathway system shall extend throughout the development site and connect to adjacent sidewalks, and to all future phases of the development, as applicable.

Response: The project design proposes sidewalks along the frontages of all lots providing a continuous pathway system throughout the community. In addition to the sidewalks, a meandering pedestrian pathway is proposed within Tract A providing a convenient pedestrian connection and recreational opportunities in the open space area. A pedestrian crossing is provided through the block bounded by Windflower Street, Yarrow Lane, and Trillium Street.

2. Safe, Direct, and Convenient. Pathways within developments shall provide safe, reasonably direct, and convenient connections between primary building entrances and all adjacent parking areas, recreational areas/playgrounds, and public rights-of-way and crosswalks based on all of the following criteria:

a. Pedestrian pathways are designed primarily for pedestrian safety and convenience, meaning they are free from hazards and provide a reasonably smooth and consistent surface.

b. The pathway is reasonably direct. A pathway is reasonably direct when it follows a route between destinations that does not involve a significant amount of unnecessary out-of-direction travel.

c. The pathway connects to all primary building entrances and is consistent with the Americans with Disabilities Act (ADA) requirements.

d. All parking lots larger than three acres in size shall provide an internal bicycle and pedestrian pathway pursuant to Section 4.155(.03)(B.)(3.)(d.).

Response: The on-site pedestrian access and circulation system is generally consistent with Frog Pond West Master Plan Figure 18, Street Demonstration Plan. It provides safe, direct, and convenient connections both internally and to the surrounding street network.

-
3. **Vehicle/Pathway Separation.** Except as required for crosswalks, per subsection 4, below, where a pathway abuts a driveway or street it shall be vertically or horizontally separated from the vehicular lane. For example, a pathway may be vertically raised six inches above the abutting travel lane, or horizontally separated by a row of bollards.

Response: The proposed design vertically and/or horizontally separates all sidewalks and pathways from vehicle travel lanes except for private driveways and crosswalks.

4. **Crosswalks.** Where a pathway crosses a parking area or driveway, it shall be clearly marked with contrasting paint or paving materials (e.g., pavers, light-color concrete inlay between asphalt, or similar contrast).

Response: The proposed pathway does not cross a parking area or driveway. This standard is not applicable.

5. **Pathway Width and Surface.** Primary pathways shall be constructed of concrete, asphalt, brick/masonry pavers, or other durable surface, and not less than five (5) feet wide. Secondary pathways and pedestrian trails may have an alternative surface except as otherwise required by the ADA.

Response: As shown on the Preliminary Street Plan (Exhibit A), the pedestrian pathway is paved and is 10 feet wide, and widens to 15 feet around the stormwater pond where vehicular access must be provided for maintenance.

6. **All pathways shall be clearly marked with appropriate standard signs.**

Response: The pedestrian pathways will be signed as required.

Section 4.155 **GENERAL REGULATIONS - PARKING, LOADING AND BICYCLE PARKING**

[...]

- G. Table[s] 5 shall be used to determine the minimum and maximum parking standards for various land uses. The minimum number of required parking spaces shown on Tables 5 shall be determined by rounding to the nearest whole parking space. Structured parking and on-street parking are exempted from the parking maximums in Table 5. [Amended by Ordinance No. 538, 2/21/02.]

Response: Table 5 requires that single-family units provide 1 parking space per dwelling unit. There is no maximum number listed. Each lot will accommodate a single-family home with a two-car garage and a driveway. Dimensional standards will be reviewed during building permit submittal.

(.04) **Bicycle Parking:**

- A. **Required Bicycle Parking - General Provisions.**

1. The required minimum number of bicycle parking spaces for each use category is shown in Table 5, Parking Standards.[...]

Response: Table 5 states that there is no minimum bicycle parking requirement for single-family homes.

Section 4.167 **GENERAL REGULATIONS - ACCESS, INGRESS AND EGRESS**

-
- (.01) Each access onto streets or private drives shall be at defined points as approved by the City and shall be consistent with the public's health, safety and general welfare. Such defined points of access shall be approved at the time of issuance of a building permit if not previously determined in the development permit. [Amended by Ord. 682, 9/9/10]

Response: Driveways will be shown on construction drawings and will be approved at the time of building permit issuance.

Section 4.171 PROTECTION OF NATURAL FEATURES AND OTHER RESOURCES

(.02) General Terrain Preparation:

- A. All developments shall be planned, designed, constructed and maintained with maximum regard to natural terrain features and topography, especially hillside areas, floodplains, and other significant landforms.
- B. All grading, filling and excavating done in connection with any development shall be in accordance with the Uniform Building Code
- C. In addition to any permits required under the Uniform Building Code, all developments shall be planned, designed, constructed and maintained so as to:
 - 1. Limit the extent of disturbance of soils and site by grading, excavation and other land alterations.
 - 2. Avoid substantial probabilities of: (1) accelerated erosion; (2) pollution, contamination, or siltation of lakes, rivers, streams and wetlands; (3) damage to vegetation; (4) injury to wildlife and fish habitats.
 - 3. Minimize the removal of trees and other native vegetation that stabilize hillsides, retain moisture, reduce erosion, siltation and nutrient runoff, and preserve the natural scenic character.

Response: The site has been planned and designed to avoid the natural features on the site. Grading, filling, and excavating will be conducted in accordance with the Uniform Building code. The site will be protected with erosion control measures. Where removal of trees is necessary for the construction of homes and public streets, replacement trees will be planted per the provisions of this code.

- (.03) Hillsides: All developments proposed on slopes greater than 25% shall be limited to the extent that: [...]

Response: No slopes greater than 25 percent are present on the site.

(.04) Trees and Wooded Areas.

- A. All developments shall be planned, designed, constructed and maintained so that:
 - 1. Existing vegetation is not disturbed, injured, or removed prior to site development and prior to an approved plan for circulation, parking and structure location.
 - 2. Existing wooded areas, significant clumps/groves of trees and vegetation, and all trees with a diameter at breast height of six inches or greater shall be incorporated into the development plan and protected wherever feasible.
 - 3. Existing trees are preserved within any right-of-way when such trees are suitably located, healthy, and when approved grading allows.

-
- B. Trees and woodland areas to be retained shall be protected during site preparation and construction according to City Public Works design specifications, by:
 - 1. Avoiding disturbance of the roots by grading and/or compacting activity.
 - 2. Providing for drainage and water and air filtration to the roots of trees which will be covered with impermeable surfaces.
 - 3. Requiring, if necessary, the advisory expertise of a registered arborist/horticulturist both during and after site preparation.
 - 4. Requiring, if necessary, a special maintenance, management program to insure survival of specific woodland areas of specimen trees or individual heritage status trees.

Response: Existing vegetation will not be disturbed, injured, or removed prior to land use and permit approvals. Existing trees have been retained wherever possible; however, many trees will need to be removed to provide area for home construction. The existing grove of Oak trees in the northeast of the site has been prioritized for protection and incorporated into open space. The finished pathway will be built on grade according to the construction plan specified in the Arborist Report and its location within the grove will be somewhat flexible to allow the project arborist and construction crew to preserve large roots that may be encountered. Trees identified to be retained will be protected during site preparation and construction according to the City Public Works design specifications as outlined in the Arborist Report and Conditions of Approval.

(.05) High Voltage Powerline Easements and Rights of Way and Petroleum Pipeline Easements:

- A. Due to the restrictions placed on these lands, no residential structures shall be allowed within high voltage powerline easements and rights of way and petroleum pipeline easements, and any development, particularly residential, adjacent to high voltage powerline easements and rights of way and petroleum pipeline easements shall be carefully reviewed.
- B. Any proposed non-residential development within high voltage powerline easements and rights of way and petroleum pipeline easements shall be coordinated with and approved by the Bonneville Power Administration, Portland General Electric Company or other appropriate utility, depending on the easement or right of way ownership.

Response: No structures are proposed within the powerline easement.

(.07) Standards for Earth Movement Hazard Areas:

- A. No development or grading shall be allowed in areas of land movement, slump or earth flow, and mud or debris flow, except under one of the following conditions:
 - 1. Stabilization of the identified hazardous condition based on established and proven engineering techniques which ensure protection of public and private property. Appropriate conditions of approval may be attached by the City.
 - 2. An engineering geologic study approved by the City establishing that the site is stable for the proposed use and development. The study shall include the following: a. Index map.

- b. Project description, to include: location; topography, drainage, vegetation; discussion of previous work; and discussion of field exploration methods.
 - c. Site geology, to include: site geologic map; description of bedrock and superficial materials including artificial fill; location of any faults, folds, etc.; and structural data including bedding, jointing, and shear zones.
 - d. Discussion and analysis of any slope stability problems.
 - e. Discussion of any off-site geologic conditions that may pose a potential hazard to the site or that may be affected by on-site development.
 - f. Suitability of site for proposed development from geologic standpoint.
 - g. Specific recommendations for cut slope stability, seepage and drainage control, or other design criteria to mitigate geologic hazards.
 - h. Supportive data, to include: cross sections showing subsurface structure; graphic logs of subsurface explorations; results of laboratory tests; and references.
 - i. Signature and certification number of engineering geologist registered in the State of Oregon.
 - j. Additional information or analyses as necessary to evaluate the site.
- B. Vegetative cover shall be maintained or established for stability and erosion control purposes.
 - C. Diversion of storm water into these areas shall be prohibited.
 - D. The principal source of information for determining earth movement hazards is the State Department of Geology and Mineral Industries (DOGAMI) Bulletin 99 and any subsequent bulletins and accompanying maps. Approved site specific engineering geologic studies shall be used to identify the extent and severity of the hazardous conditions on the site, and to update the earth movement hazards database.

Response: Geotechnical investigation has been completed for the subject property, and no earth movement hazards have been identified. See Exhibit H for the geotechnical report.

(.08) Standards for Soil Hazard Areas:

- A. Appropriate siting and design safeguards shall insure structural stability and proper drainage of foundation and crawl space areas for development on land with any of the following soil conditions: wet or high water table; high shrink-swell capability; compressible or organic; and shallow depth-to-bedrock.
- B. The principal source of information for determining soil hazards is the State DOGAMI Bulletin 99 and any subsequent bulletins and accompanying maps. Approved site-specific soil studies shall be used to identify the extent and severity of the hazardous conditions on the site, and to update the soil hazards database accordingly.

Response: Geotechnical investigation has been completed for the subject property, and no soil hazard areas have been identified. See Exhibit H for the geotechnical report.

(.09) Historic Protection: Purpose:



-
- A. To preserve structures, sites, objects, and areas within the City of Wilsonville having historic, cultural, or archaeological significance.

Response: No historic, cultural, or archaeological items have been identified on the site.

Section 4.175 PUBLIC SAFETY AND CRIME PREVENTION.

- (.01) All developments shall be designed to deter crime and ensure public safety.
- (.02) Addressing and directional signing shall be designed to assure identification of all buildings and structures by emergency response personnel, as well as the general public.
- (.03) Areas vulnerable to crime shall be designed to allow surveillance. Parking and loading areas shall be designed for access by police in the course of routine patrol duties.
- (.04) Exterior lighting shall be designed and oriented to discourage crime.

Response: The Frog Pond Crossing community has been designed to deter crime and ensure public safety. Streets and pedestrian connections will be lit for visibility and safety. Homes will be oriented toward these streets to provide “eyes on the street.” All dwellings will be addressed per Building and Fire Department requirements to allow identification for emergency response personnel. No parking and loading areas are proposed. Dwellings will have exterior porch lighting, which will support the streetlights to provide safety and visibility. These standards are met.

Section 4.176 LANDSCAPING, SCREENING, AND BUFFERING

- (.02) Landscaping and Screening Standards.

[...]

- C. General Landscaping Standard.

1. Intent. The General Landscaping Standard is a landscape treatment for areas that are generally open. It is intended to be applied in situations where distance is used as the principal means of separating uses or developments and landscaping is required to enhance the intervening space. Landscaping may include a mixture of ground cover, evergreen and deciduous shrubs, and coniferous and deciduous trees.
2. Required materials. Shrubs and trees, other than street trees, may be grouped. Ground cover plants must fully cover the remainder of the landscaped area (see Figure 21: General Landscaping). The General Landscaping Standard has two different requirements for trees and shrubs:
 - a. Where the landscaped area is less than 30 feet deep, one tree is required for every 30 linear feet.
 - b. Where the landscaped area is 30 feet deep or greater, one tree is required for every 800 square feet and two high shrubs or three low shrubs are required for every 400 square feet.

Response: This project is a single-family residential neighborhood and is subject to the General Landscape Standard, with the exception of lots abutting Stafford Road, which are subject to Low Screen Landscaping Standards and the Frog Pond West Master Plan. The Preliminary Landscape Plan and the Preliminary Frontage Buffer Landscape Plan provide details of proposed landscaping in these areas.

D. Low Screen Landscaping Standard.

2. Required materials. The Low Screen Landscaping Standard requires sufficient low shrubs to form a continuous screen three (3) feet high and 95% opaque, year-round. In addition, one tree is required for every 30 linear feet of landscaped area, or as otherwise required to provide a tree canopy over the landscaped area. Ground cover plants must fully cover the remainder of the landscaped area. A three (3) foot high masonry wall or a berm may be substituted for the shrubs, but the trees and ground cover plants are still required. When applied along street lot lines, the screen or wall is to be placed along the interior side of the landscaped area. (See Figure 22: Low Screen Landscaping).

Response: The Low Screen Landscape standard will be applied in Tract D along Stafford Road, with landscaping comprised of low shrubs and ornamental plants at the foundation of the brick wall to offer variety and visual interest. Please refer to the Preliminary Frontage Buffer Landscape Plan (Exhibit A).

I. Partially Sight-Obscuring Fence Standard.

2. Required materials. Partially Sight-Obscuring Fence Standard are to be at least six (6) feet high and at least 50% sight-obscuring. Fences may be made of wood (other than plywood or particle-board), metal, bricks, masonry or other permanent materials (see Figure 26: Partially Sight-Obscuring Fence).

Response: A 4-foot-high brick wall with a 2-foot-high wrought iron fence over the top will be provided along Stafford Road, in compliance with Frog Pond West Master Plan.

- (.03) Landscape Area. Not less than fifteen percent (15%) of the total lot area, shall be landscaped with vegetative plant materials. The ten percent (10%) parking area landscaping required by section 4.155.03(B)(1) is included in the fifteen percent (15%) total lot landscaping requirement. Landscaping shall be located in at least three separate and distinct areas of the lot, one of which must be in the contiguous frontage area. Planting areas shall be encouraged adjacent to structures. Landscaping shall be used to define, soften or screen the appearance of buildings and off-street parking areas. Materials to be installed shall achieve a balance between various plant forms, textures, and heights. The installation of native plant materials shall be used whenever practicable. (For recommendations refer to the Native Plant List maintained by the City of Wilsonville). [Amended by Ord. # 674 11/16/09]

Response: Landscaping on individual private lots will be reviewed at the time of building permit submittal. The Preliminary Landscape Plan included in Exhibit A illustrates the location and type of landscaping within public rights-of-way and open space tracts.

(.06) Plant Materials.

- A. Shrubs and Ground Cover. All required ground cover plants and shrubs must be of sufficient size and number to meet these standards within three (3) years of planting. Non-horticultural plastic sheeting or other impermeable surface shall not be placed under mulch. Native topsoil shall be preserved and reused to the extent feasible. Surface mulch or bark dust are to be fully raked into soil of appropriate depth, sufficient to control erosion, and are confined to areas around plantings. Areas exhibiting only surface mulch, compost or barkdust are not to be used as substitutes for plant areas. [Amended by Ord. # 674 11/16/09]

-
1. Shrubs. All shrubs shall be well branched and typical of their type as described in current AAN Standards and shall be equal to or better than 2-gallon containers and 10" to 12" spread.
 2. Ground cover. Shall be equal to or better than the following depending on the type of plant materials used: gallon containers spaced at 4 feet on center minimum, 4" pot spaced 2 feet on center minimum, 2-1/4" pots spaced at 18 inch on center minimum. No bare root planting shall be permitted. Ground cover shall be sufficient to cover at least 80% of the bare soil in required landscape areas within three (3) years of planting. Where wildflower seeds are designated for use as a ground cover, the City may require annual re-seeding as necessary.
 3. Turf or lawn in non-residential developments. Shall not be used to cover more than ten percent (10%) of the landscaped area, unless specifically approved based on a finding that, due to site conditions and availability of water, a larger percentage of turf or lawn area is appropriate. Use of lawn fertilizer shall be discouraged. Irrigation drainage runoff from lawns shall be retained within lawn areas.
 4. Plant materials under trees or large shrubs. Appropriate plant materials shall be installed beneath the canopies of trees and large shrubs to avoid the appearance of bare ground in those locations.
 5. Integrate compost-amended topsoil in all areas to be landscaped, including lawns, to help detain runoff, reduce irrigation and fertilizer needs, and create a sustainable, low-maintenance landscape. [Added by Ord. # 674 11/16/09]

Response: The Preliminary Landscape Plan (Exhibit A) demonstrates compliance with these requirements.

- B. Trees. All trees shall be well-branched and typical of their type as described in current American Association of Nurserymen (AAN) Standards and shall be balled and burlapped. The trees shall be grouped as follows:
 1. Primary trees which define, outline or enclose major spaces, such as Oak, Maple, Linden, and Seedless Ash, shall be a minimum of 2" caliper.
 2. Secondary trees which define, outline or enclose interior areas, such as Columnar Red Maple, Flowering Pear, Flame Ash, and Honeylocust, shall be a minimum of 1-3/4" to 2" caliper.
 3. Accent trees which, are used to add color, variation and accent to architectural features, such as Flowering Pear and Kousa Dogwood, shall be 1-3/4" minimum caliper.
 4. Large conifer trees such as Douglas Fir or Deodar Cedar shall be installed at a minimum height of eight (8) feet.
 5. Medium-sized conifers such as Shore Pine, Western Red Cedar or Mountain Hemlock shall be installed at a minimum height of five to six (5 to 6) feet.

Response: The Preliminary Landscape Plan (Exhibit A) addresses these requirements, as applicable.

- D. Street Trees. In order to provide a diversity of species, the Development Review Board may require a mix of street trees throughout a development. Unless the Board waives the requirement for reasons supported by a finding

in the record, different types of street trees shall be required for adjoining blocks in a development.

1. All trees shall be standard base grafted, well branched and typical of their type as described in current AAN Standards and shall be balled and burlapped (b&b). Street trees shall be planted at sizes in accordance with the following standards: a. Arterial streets - 3" minimum caliper
- b. Collector streets - 2" minimum caliper.
- c. Local streets or residential private access drives - 1-3/4" minimum caliper. [Amended by Ord. 682, 9/9/10]
- d. Accent or median tree -1-3/4" minimum caliper.

Response: The project has frontage on Frog Pond Lane, which is classified as a Collector-Gateway between Stafford Road and Willow Creek Drive. The other streets within the neighborhood are classified as Local Streets and a Private Alley. As shown on the Preliminary Landscape Plan (Exhibit A), the project complies with the above street tree requirements.

2. The following trees and varieties thereof are considered satisfactory street trees in most circumstances; however, other varieties and species are encouraged and will be considered: a. Trees over 50 feet mature height: Quercus garryana (Native Oregon White Oak), Quercus rubra borealis (Red Oak), Acer Macrophyllum (Native Big Leaf Maple), Acer nigrum (Green Column Black Maple), Fraxinus americanus (White Ash), Fraxinus pennsylvannica 'Marshall' (Marshall Seedless Green Ash), Quercus coccinea (Scarlet Oak), Quercus pulustris (Pin Oak), Tilia americana (American Linden).
- b. Trees under 50 feet mature height: Acer rubrum (Red Sunset Maple), Cornus nuttallii (Native Pacific Dogwood), Gleditsia triacanthos (Honey Locust), Pyrus calleryana 'Bradford' (Bradford Pear), Tilia cordata (Little Leaf Linden), Fraxinus oxycarpa (Flame Ash).
- c. Other street tree species. Other species may be specified for use in certain situations. For instance, evergreen species may be specified where year-round color is desirable and no adverse effect on solar access is anticipated. Water-loving species may be specified in low locations where wet soil conditions are anticipated. [Section 4.176(.06)(D.) amended by Ordinance No. 538, 2/21/02.]

Response: Street trees have been selected in accordance with Figure 43, Street Tree Plan, and Table 2, Street Tree List of the Frog Pond West Master Plan.

E. Types of Plant Species.

1. Existing landscaping or native vegetation may be used to meet these standards, if protected and maintained during the construction phase of the development and if the plant species do not include any that have been listed by the City as prohibited. The existing native and nonnative vegetation to be incorporated into the landscaping shall be identified.
2. Selection of plant materials. Landscape materials shall be selected and sited to produce hardy and drought-tolerant landscaping. Selection shall be based on soil characteristics, maintenance

requirements, exposure to sun and wind, slope and contours of the site, and compatibility with other vegetation that will remain on the site. Suggested species lists for street trees, shrubs and groundcovers shall be provided by the City of Wilsonville.

3. Prohibited plant materials. The City may establish a list of plants that are prohibited in landscaped areas. Plants may be prohibited because they are potentially damaging to sidewalks, roads, underground utilities, drainage improvements, or foundations, or because they are known to be invasive to native vegetation.

[Section 4.176(.06)(E.) amended by Ordinance No. 538, 2/21/02.]

Response: As shown the Preliminary Landscape Plan (Exhibit A), the proposed landscape materials include a mix of native trees, shrubs, and groundcovers. No prohibited plant materials are proposed.

F. Tree Credit.

Existing trees that are in good health as certified by an arborist and are not disturbed during construction may count for landscaping tree credit as follows (measured at four and one-half feet above grade and rounded to the nearest inch):

Existing trunk diameter	Number of Tree Credits
18 to 24 inches in diameter	3 tree credits
25 to 31 inches in diameter	4 tree credits
32 inches or greater	5 tree credits

1. It shall be the responsibility of the owner to use reasonable care to maintain preserved trees. Trees preserved under this section may only be removed if an application for removal permit under Section 4.610.10(01)(H) has been approved. Required mitigation for removal shall be replacement with the number of trees credited to the preserved and removed tree.
2. Within five years of occupancy and upon notice from the City, the property owner shall replace any preserved tree that cannot be maintained due to disease or damage, or hazard or nuisance as defined in Chapter 6 of this code. The notice shall be based on complete information provided by an arborist Replacement with the number of trees credited shall occur within one (1) growing season of notice.

Response: As shown on the Preliminary Landscape Plan (Exhibit A), 23 trees are planned to be protected, including 2 line trees in good condition over 24 inches in diameter. As shown in Table 4 below, these retained trees may count for 9 tree credits.

Table 4. Tree Credits

Tag #	Existing Trunk Diameter	Number of Tree Credits
20122	26"	4
20125	34"	5
Total:		9

(.07) Installation and Maintenance.

- A. Installation. Plant materials shall be installed to current industry standards and shall be properly staked to assure survival. Support devices (guy wires, etc.) shall not be allowed to interfere with normal pedestrian or vehicular movement.
- B. Maintenance. Maintenance of landscaped areas is the on-going responsibility of the property owner. Any landscaping installed to meet the requirements of this Code, or any condition of approval established by a City decision-making body acting on an application, shall be continuously maintained in a healthy, vital and acceptable manner. Plants that die are to be replaced in kind, within one growing season, unless appropriate substitute species are approved by the City. Failure to maintain landscaping as required in this Section shall constitute a violation of this Code for which appropriate legal remedies, including the revocation of any applicable land development permits, may result.
- C. Irrigation. The intent of this standard is to assure that plants will survive the critical establishment period when they are most vulnerable due to a lack of watering and also to assure that water is not wasted through unnecessary or inefficient irrigation. Approved irrigation system plans shall specify one of the following:
 - 1. A permanent, built-in, irrigation system with an automatic controller. Either a spray or drip irrigation system, or a combination of the two, may be specified.
 - 2. A permanent or temporary system designed by a landscape architect licensed to practice in the State of Oregon, sufficient to assure that the plants will become established and drought-tolerant.
 - 3. Other irrigation system specified by a licensed professional in the field of landscape architecture or irrigation system design.
 - 4. A temporary permit issued for a period of one year, after which an inspection shall be conducted to assure that the plants have become established. Any plants that have died, or that appear to the Planning Director to not be thriving, shall be appropriately replaced within one growing season. An inspection fee and a maintenance bond or other security sufficient to cover all costs of replacing the plant materials shall be provided, to the satisfaction of the Community Development Director. Additionally, the applicant shall provide the City with a written license or easement to enter the property and cause any failing plant materials to be replaced.
- D. Protection. All required landscape areas, including all trees and shrubs, shall be protected from potential damage by conflicting uses or activities including vehicle parking and the storage of materials.

Response: As detailed in Note 6 of the Preliminary Landscape Plan (Exhibit A), all landscape areas will be watered by a fully automatic underground irrigation system. These standards are met.

- (.09) Landscape Plans. Landscape plans shall be submitted showing all existing and proposed landscape areas. Plans must be drawn to scale and show the type, installation size, number and placement of materials. Plans shall include a plant material list. Plants are to be identified by both their scientific and common names. The condition of any existing plants and the proposed method of irrigation are also to be indicated. Landscape plans shall divide all landscape areas into the following categories based on projected water consumption for irrigation:

-
- A. High water usage areas (+/- two (2) inches per week): small convoluted lawns, lawns under existing trees, annual and perennial flower beds, and temperamental shrubs;
 - B. Moderate water usage areas (+/- one (1) inch per week): large lawn areas, average water-using shrubs, and trees;
 - C. Low water usage areas (Less than one (1) inch per week, or gallons per hour): seeded fieldgrass, swales, native plantings, drought-tolerant shrubs, and ornamental grasses or drip irrigated areas.
 - D. Interim or unique water usage areas: areas with temporary seeding, aquatic plants, erosion control areas, areas with temporary irrigation systems, and areas with special water-saving features or water harvesting irrigation capabilities. These categories shall be noted in general on the plan and on the plant material list.

Response: A Preliminary Landscape Plan (Exhibit A) is included in the plan set (Exhibit A). Individual lot landscaping will be proposed at the time of building permit submittal.

- (.10) Completion of Landscaping. The installation of plant materials may be deferred for a period of time specified by the Board or Planning Director acting on an application, in order to avoid hot summer or cold winter periods, or in response to water shortages. In these cases, a temporary permit shall be issued, following the same procedures specified in subsection (.07)(C)(3), above, regarding temporary irrigation systems. No final Certificate of Occupancy shall be granted until an adequate bond or other security is posted for the completion of the landscaping, and the City is given written authorization to enter the property and install the required landscaping, in the event that the required landscaping has not been installed. The form of such written authorization shall be submitted to the City Attorney for review.

Response: No deferral is requested at this time but may be requested in the future subject to the scenarios above. This requirement is acknowledged.

- (.11) Street Trees Not Typically Part of Site Landscaping. Street trees are not subject to the requirements of this Section and are not counted toward the required standards of this Section. Except, however, that the Development Review Board may, by granting a waiver or variance, allow for special landscaping within the right-of-way to compensate for a lack of appropriate on-site locations for landscaping. See subsection (.06), above, regarding street trees.

Response: No waiver or variance for on-site landscaping is requested. This standard is not applicable.

- (.12) Mitigation and Restoration Plantings. A mitigation plan is to be approved by the City's Development Review Board before the destruction, damage, or removal of any existing native plants. Plantings intended to mitigate the loss of native vegetation are subject to the following standards. Where these standards conflict with other requirements of this Code, the standards of this Section shall take precedence. The desired effect of this section is to preserve existing native vegetation.
 - A. Plant Sources. Plant materials are to be native and are subject to approval by the City. They are to be non-clonal in origin; seed source is to be as local as possible, and plants must be nursery propagated or taken from a pre-approved transplantation area. All of these requirements are to be addressed in any proposed mitigation plan.
 - B. Plant Materials. The mitigation plan shall specify the types and installation sizes of plant materials to be used for restoration. Practices such as the use of pesticides, fungicides, and fertilizers shall not be employed in mitigation areas unless specifically authorized and approved.

- C. Installation. Install native plants in suitable soil conditions. Plant materials are to be supported only when necessary because of extreme winds at the site. Where support is necessary, all stakes, guy wires or other measures are to be removed as soon as the plants can support themselves. Protect from animal and fowl predation and foraging until establishment.
- D. Irrigation. Permanent irrigation systems are generally not appropriate in restoration situations, and manual or temporary watering of new plantings is often necessary. The mitigation plan shall specify the method and frequency of manual watering, including any that may be necessary after the first growing season.
- E. Monitoring and Reporting. Monitoring of native landscape areas is the on-going responsibility of the property owner. Plants that die are to be replaced in kind and quantity within one year. Written proof of the survival of all plants shall be required to be submitted to the City's Planning Department one year after the planting is completed.

[Section 4.176 amended by Ordinance No. 812, 2/22/18]

Response: The site is currently in residential and agricultural use, and site plantings consist primarily of grass and clustered trees. The existing grass and some of the trees will be removed for site development, specifically to accommodate the planned street network and desired lot pattern. Tree removal will be mitigated as detailed in the response to Section 4.610.40.

Section 4.177 STREET IMPROVEMENT STANDARDS

- (.01) Development and related public facility improvements shall comply with the standards in this section, the Wilsonville Public Works Standards, and the Transportation System Plan, in rough proportion to the potential impacts of the development. Such improvements shall be constructed at the time of development or as provided by Section 4.140, except as modified or waived by the City Engineer for reasons of safety or traffic operations.

Response: The proposed public facility improvements are designed to comply with the standards in this section, the Wilsonville Public Works Standards, and the Transportation System Plan as modified by the Frog Pond Master Plan and as approved by the City Engineer. Final approval will occur with review and issuance of the Public Works construction permit.

The Development will construct the remaining width of Frog Pond Lane and the bicycle/pedestrian facilities associated with it. The SW Stafford Road facilities will be constructed by the City as part of the larger project and the applicant will pay the required impact fees for their portion of the Stafford Road improvements.

- (.02) Street Design Standards.
 - A. All street improvements and intersections shall provide for the continuation of streets through specific developments to adjoining properties or subdivisions.
 - 1. Development shall be required to provide existing or future connections to adjacent sites through the use of access easements where applicable. Such easements shall be required in addition to required public street dedications as required in Section 4.236(.04).

Response: The street network has been designed in substantial compliance with the Frog Pond West Street Demonstration Plan. Future connections to adjacent sites are anticipated to the south and west.

-
- B. The City Engineer shall make the final determination regarding right-of-way and street element widths using the ranges provided in Chapter 3 of the Transportation System Plan and the additional street design standards in the Public Works Standards.

Response: The applicant does not propose revisions to the right-of-way or street element width for Frog Pond Lane.

C. Rights-of-way.

1. Prior to issuance of a Certificate of Occupancy Building permits or as a part of the recordation of a final plat, the City shall require dedication of rights-of-way in accordance with the Transportation System Plan. All dedications shall be recorded with the County Assessor's Office.
2. The City shall also require a waiver of remonstrance against formation of a local improvement district, and all non-remonstrances shall be recorded in the County Recorder's Office as well as the City's Lien Docket, prior to issuance of a Certificate of Occupancy Building Permit or as a part of the recordation of a final plat.
3. In order to allow for potential future widening, a special setback requirement shall be maintained adjacent to all arterial streets. The minimum setback shall be 55 feet from the centerline or 25 feet from the right-of-way designated on the Master Plan, whichever is greater.

Response: The site abuts SW Stafford Road to the east, which is an arterial street. The project will dedicate 12 feet of right-of-way to the western Stafford Road frontage, which will increase the right-of-way to 76 feet. The tentative subdivision plat shows right-of-way dedication.

- D. Dead-end Streets. New dead-end streets or cul-de-sacs shall not exceed 200 feet in length, unless the adjoining land contains barriers such as existing buildings, railroads or freeways, or environmental constraints such as steep slopes, or major streams or rivers, that prevent future street extension and connection. A central landscaped island with rainwater management and infiltration are encouraged in cul-de-sac design. No more than 25 dwelling units shall take access to a new dead-end or cul-de-sac street unless it is determined that the traffic impacts on adjacent streets will not exceed those from a development of 25 or fewer units. All other dimensional standards of dead-end streets shall be governed by the Public Works Standards. Notification that the street is planned for future extension shall be posted on the dead-end street. [Amended by Ord. # 674 11/16/09]

Response: The street network has been designed per the Frog Pond West Master Plan Street Demonstration Plan. No dead-end streets are proposed by the applicant.

E. Corner or clear vision area.

1. A clear vision area which meets the Public Works Standards shall be maintained on each corner of property at the intersection of any two streets, a street and a railroad or a street and a driveway. However, the following items shall be exempt from meeting this requirement:
 - a. Light and utility poles with a diameter less than 12 inches.
 - b. Trees less than 6" d.b.h., approved as a part of the Stage II Site Design, or administrative review.

-
- c. Except as allowed by b., above, an existing tree, trimmed to the trunk, 10 feet above the curb.
 - d. Official warning or street sign.
 - e. Natural contours where the natural elevations are such that there can be no crossvisibility at the intersection and necessary excavation would result in an unreasonable hardship on the property owner or deteriorate the quality of the site.

Response: Clear vision areas will be maintained at the corner of each property.

- F. Vertical clearance - a minimum clearance of 12 feet above the pavement surface shall be maintained over all streets and access drives.

Response: Vertical clearances will be maintained at all streets and access drives.

- G. Interim improvement standard. It is anticipated that all existing streets, except those in new subdivisions, will require complete reconstruction to support urban level traffic volumes. However, in most cases, existing and short-term projected traffic volumes do not warrant improvements to full Master Plan standards. Therefore, unless otherwise specified by the Development Review Board, the following interim standards shall apply.
 - 1. Arterials - 24 foot paved, with standard sub-base. Asphalt overlays are generally considered unacceptable, but may be considered as an interim improvement based on the recommendations of the City Engineer, regarding adequate structural quality to support an overlay.
 - 2. Half-streets are generally considered unacceptable. However, where the Development Review Board finds it essential to allow for reasonable development, a half-street may be approved. Whenever a half-street improvement is approved, it shall conform to the requirements in the Public Works Standards:
 - 3. When considered appropriate in conjunction with other anticipated or scheduled street improvements, the City Engineer may approve street improvements with a single asphalt lift. However, adequate provision must be made for interim storm drainage, pavement transitions at seams and the scheduling of the second lift through the Capital Improvements Plan. [Amended by Ord. 610, 5/1/06]

Response: This project is a new subdivision. The Interim Improvement standards do not apply.

- (.03) Sidewalks. Sidewalks shall be provided on the public street frontage of all development. Sidewalks shall generally be constructed within the dedicated public right-of-way, but may be located outside of the right-of-way within a public easement with the approval of the City Engineer.
 - A. Sidewalk widths shall include a minimum through zone of at least five feet. The through zone may be reduced pursuant to variance procedures in Section 4.196, a waiver pursuant to Section 4.118, or by authority of the City Engineer for reasons of traffic operations, efficiency, or safety.
 - B. Within a Planned Development, the Development Review Board may approve a sidewalk on only one side. If the sidewalk is permitted on just one side of the street, the owners will be required to sign an agreement to an assessment in the future to construct the other sidewalk if the City Council decides it is necessary.

Response: As shown on the Preliminary Street Plan (Exhibit A), all sidewalks within Frog Pond Crossing are at least 5 feet wide. No adjustments are requested.

(.04) **Bicycle Facilities.** Bicycle facilities shall be provided to implement the Transportation System Plan, and may include on-street and off-street bike lanes, shared lanes, bike boulevards, and cycle tracks. The design of on-street bicycle facilities will vary according to the functional classification and the average daily traffic of the facility.

Response: As shown on the Preliminary Street Plan (Exhibit A), the proposed street cross-sections comply with the street classifications and cross-sections identified in the Frog Pond West Master Plan. Frog Pond Lane cross-section includes buffered bike lanes; bikes will share the vehicular lane with vehicles in the local streets. These standards are met.

(.05) **Multiuse Pathways.** Pathways may be in addition to, or in lieu of, a public street. Paths that are in addition to a public street shall generally run parallel to that street, and shall be designed in accordance with the Public Works Standards or as specified by the City Engineer. Paths that are in lieu of a public street shall be considered in areas only where no other public street connection options are feasible and are subject to the following standards.

- A. Paths shall be located to provide a reasonably direct connection between likely pedestrian and bicyclist destinations. Additional standards relating to entry points, maximum length, visibility, and path lighting are provided in the Public Works Standards.
- B. To ensure ongoing access to and maintenance of pedestrian/bicycle paths, the City Engineer will require dedication of the path to the public and acceptance of the path by the City as public right-of-way; or creation of a public access easement over the path.

Response: Several pedestrian connections are proposed within the community. A pedestrian trail through Open Space Tract A connects the residential neighborhood to the open space in the northeast portion of the site and to the exterior perimeter streets (SW Kahle Road and SW Stafford Road). An interior pedestrian pathway is proposed at a mid-block crossing between Trillium Street and Windflower Street, where the Frog Pond West Master Plan envisions a public street. Since the proposed street network within the subdivision does not exactly match the conceptual Street Demonstration Plan, this pathway achieves the desired connectivity in that particular block. Please see responses to WDC Section 4.127(.10), above, for more details.

(.06) **Transit Improvements**

Development on sites that are adjacent to or incorporate major transit streets shall provide improvements as described in this section to any bus stop located along the site's frontage, unless waived by the City Engineer for reasons of safety or traffic operations. Transit facilities include bus stops, shelters, and related facilities. Required transit facility improvements may include the dedication of land or the provision of a public easement.[...]

Response: The site is not adjacent to any transit routes. These standards are not applicable.

(.07) **Residential Private Access Drives.** Residential Private Access Drives shall meet the following standards:

- A. Residential Private Access Drives shall provide primary vehicular access to no more than four (4) dwelling units, excluding accessory dwelling units.

Response: No private access drives are proposed. Tract B is a private alley; therefore, this requirement does not apply.

(.08) Access Drive and Driveway Approach Development Standards.

- A. An access drive to any proposed development shall be designed to provide a clear travel lane free from any obstructions.
- B. Access drive travel lanes shall be constructed with a hard surface capable of carrying a 23-ton load.
- C. Where emergency vehicle access is required, approaches and driveways shall be designed and constructed to accommodate emergency vehicle apparatus and shall conform to applicable fire protection requirements. The City may restrict parking, require signage, or require other public safety improvements pursuant to the recommendations of an emergency service provider.
- D. Secondary or emergency access lanes may be improved to a minimum 12 feet with an all-weather surface as approved by the Fire District. All fire lanes shall be dedicated easements.
- E. Minimum access requirements shall be adjusted commensurate with the intended function of the site based on vehicle types and traffic generation.
- F. The number of approaches on higher classification streets (e.g., collector and arterial streets) shall be minimized; where practicable, access shall be taken first from a lower classification street.
- G. The City may limit the number or location of connections to a street, or impose access restrictions where the roadway authority requires mitigation to alleviate safety or traffic operations concerns.
- H. The City may require a driveway to extend to one or more edges of a parcel and be designed to allow for future extension and inter-parcel circulation as adjacent properties develop. The City may also require the owner(s) of the subject site to record an access easement for future joint use of the approach and driveway as the adjacent property(ies) develop(s).
- I. Driveways shall accommodate all projected vehicular traffic on-site without vehicles stacking or backing up onto a street.
- J. Driveways shall be designed so that vehicle areas, including but not limited to drive-up and drive-through facilities and vehicle storage and service areas, do not obstruct any public right-of-way.
- K. Approaches and driveways shall not be wider than necessary to safely accommodate projected peak hour trips and turning movements, and shall be designed to minimize crossing distances for pedestrians.
- L. As it deems necessary for pedestrian safety, the City, in consultation with the roadway authority, may require traffic-calming features, such as speed tables, textured driveway surfaces, curb extensions, signage or traffic control devices, or other features, be installed on or in the vicinity of a site.
- M. Approaches and driveways shall be located and designed to allow for safe maneuvering in and around loading areas, while avoiding conflicts with pedestrians, parking, landscaping, and buildings.
- N. Where a proposed driveway crosses a culvert or drainage ditch, the City may require the developer to install a culvert extending under and beyond the edges of the driveway on both sides of it, pursuant applicable Public Works standards.

-
- O. Except as otherwise required by the applicable roadway authority or waived by the City Engineer, temporary driveways providing access to a construction site or staging area shall be paved or graveled to prevent tracking of mud onto adjacent paved streets.

Response: As shown on the Preliminary Street Plan (Exhibit A), the project meets the above code requirements, as applicable.

- P. Unless constrained by topography, natural resources, rail lines, freeways, existing or planned or approved development, or easements or covenants, driveways proposed as part of a residential or mixed-use development shall meet local street spacing standards and shall be constructed to align with existing or planned streets, if the driveway.
 - 1. Intersects with a public street that is controlled, or is to be controlled in the planning period, by a traffic signal;
 - 2. Intersects with an existing or planned arterial or collector street; or
 - 3. Would be an extension of an existing or planned local street, or of another major driveway.

Response: As shown on the Preliminary Street Plan (Exhibit A), project streets are designed to meet local spacing standards.

(.09) Minimum street intersection spacing standards.

- A. New streets shall intersect at existing street intersections so that centerlines are not offset. Where existing streets adjacent to a proposed development do not align properly, conditions shall be imposed on the development to provide for proper alignment.
- B. Minimum intersection spacing standards are provided in Transportation System Plan Table 3-2.

Response: Marigold Terrace intersection is proposed to align with the existing street intersection on Frog Pond Lane. Marigold Terrace is the only proposed intersection with Frog Pond Lane, which is a collector. All the other streets within the proposed project are Local Streets. Per Table 3-2 of the Transportation System Plan, there are no minimum access spacing standards along Local Streets; access is permitted to each lot. No individual lot accesses are proposed on Frog Pond Lane.

(.10) Exceptions and Adjustments. The City may approve adjustments to the spacing standards of subsections (.08) and (.09) above through a Class II process, or as a waiver per Section 4.118(.03)(A.), where an existing connection to a City street does not meet the standards of the roadway authority, the proposed development moves in the direction of code compliance, and mitigation measures alleviate all traffic operations and safety concerns. Mitigation measures may include consolidated access (removal of one access), joint use driveways (more than one property uses same access), directional limitations (e.g., one-way), turning restrictions (e.g., right in/out only), or other mitigation. [Section 4.177 amended by Ord. 719, 6/17/13]

Response: No exceptions or adjustments are requested.

Section 4.180 EXCEPTIONS AND MODIFICATIONS - PROJECTIONS INTO REQUIRED YARDS

(.01) Certain non-structural architectural features are permitted to project into required yards or courts, without requiring the approval of a Variance or Reduced Setback Agreement, as follows:

-
- A. Into any required yard:
 - 1. Architectural features may project into the required yard not more than two (2) inches for each foot of required setback.
 - 2. Architectural features on buildings within the Coffee Creek Industrial Design Overlay District shall be subject to the applicable requirements in Section 4.134. : [Added by Ord. 682, 9/9/10]
 - 3. Open, unenclosed fire escapes may project a distance not exceeding forty-eight (48) inches.
 - B. Into any required yard, adjoining a street or tract with a private drive: [Amended by Ord. 682, 9/9/10]
 - 1. Architectural features may project a distance not exceeding forty (40) inches.
 - 2. An uncovered porch, terrace, or patio extending no more than two and one-half (2 1/2) feet above the finished elevation may extend within three (3) feet of an interior side lot line, or within ten (10) feet of a front lot line or of an exterior side lot line.

Response: No buildings are proposed with this application. Compliance with this section will be reviewed during a subsequent permit submittal.

Section 4.181 EXCEPTIONS & MODIFICATIONS - HEIGHT LIMITS.

Except as stipulated in Sections 4.800 through 4.804, height limitations specified elsewhere in this Code shall not apply to barns, silos or other farm buildings or structures on farms; to church spires; belfries; cupolas; and domes; monuments; water towers; windmills; chimneys; smokestacks; fire and hose towers; flag poles; above-ground electric transmission, distribution, communication and signal lines, towers and poles; and properly screened mechanical and elevator structures.

Response: No listed structures are proposed at this time. Compliance with this section will be reviewed during a subsequent permit submittal.

Section 4.182 EXCEPTIONS AND MODIFICATIONS - SETBACK MODIFICATIONS

In any residential zone where the average depth of at least two (2) existing front yards on adjoining lots or within one hundred fifty (150) feet of the lot in question and within the same block front is less or greater than the minimum or maximum front yard depth prescribed elsewhere in this Code, the required depth of the front yard on such lot shall be modified. In such case, the front yard depth shall not be less than the average depth, nor more than the greater depth, of existing front yards on at least two (2) adjoining lots within one hundred and fifty (150) feet. In the case of a corner lot, the depth of the front yard may be reduced to that of the lot immediately adjoining, provided, however, that the depth of a front yard on any corner lot shall be at least ten (10) feet.

Response: No setback modifications are requested. Compliance with this section will be reviewed during a subsequent permit submittal.

[...]

Section 4.197 ZONE CHANGES AND AMENDMENTS TO THIS CODE – PROCEDURES

(.01) The following procedure shall be followed in applying for an amendment to the text of this Chapter: [...]

Response: No zoning text amendments are proposed. This procedure is not applicable.

-
- B. All other quasi-judicial zone map amendments shall be reviewed by the Development Review Board to make a recommendation to City Council and all legislative zone map amendments shall be reviewed by the Planning Commission to make a recommendation to City Council.
 - C. In recommending approval or denial of a proposed zone map amendment, the Planning Commission or Development Review Board shall at a minimum, adopt findings addressing the following criteria:
 - 1. That the application before the Commission or Board was submitted in accordance with the procedures set forth in Section 4.008, Section 4.125 (.18)(B)(2) or, in the case of a Planned Development, Section 4.140; and [Amended by Ord 557, adopted 9/5/03]

Response: The Zone Map Amendment is being requested concurrent with a Planned Development. The application has been submitted in accordance with the procedures set forth in Section 4.140. This criterion is met.

- 2. That the proposed amendment is consistent with the Comprehensive Plan map designation and substantially complies with the applicable goals, policies and objectives, set forth in the Comprehensive Plan text; and

Response: Concurrent with the adoption of the Frog Pond West Master Plan, the City added a new zoning district, Residential Neighborhood (RN), intended for application to the Master Plan area. The applicant is requesting 8.45 acres of unincorporated land be annexed to the City of Wilsonville and have the RN zone applied. The applicable goals, policies, and objectives of the Comprehensive Plan text are addressed earlier in the narrative.

- 3. In the event that the subject property, or any portion thereof, is designated as "Residential" on the City's Comprehensive Plan Map; specific findings shall be made addressing substantial compliance with Implementation Measures 4.1.4.b, d, e, q, and x of Wilsonville's Comprehensive Plan text; and [Amended by Ordinance No. 538, 2/21/02.]

Response: Compliance with Implementation Measures 4.1.4.b, d, e, q, and x is addressed earlier in the narrative.

- 4. That the existing primary public facilities, i.e., roads and sidewalks, water, sewer and storm sewer are available and are of adequate size to serve the proposed development; or, that adequate facilities can be provided in conjunction with project development. The Planning Commission and Development Review Board shall utilize any and all means to ensure that all primary facilities are available and are adequately sized; and

Response: As addressed elsewhere in this narrative, the project will extend roads and sidewalks, water, sewer, and storm drain to serve the residents. This criterion is met.

- 5. That the proposed development does not have a significant adverse effect upon Significant Resource Overlay Zone areas, an identified natural hazard, or an identified geologic hazard. When Significant Resource Overlay Zone areas or natural hazard, and/or geologic hazard are located on or abut the proposed development, the Planning Commission or Development Review Board shall use appropriate measures to mitigate and significantly reduce conflicts

between the development and identified hazard or Significant Resource Overlay Zone and

Response: The subject site does not contain any SROZ areas, identified natural hazards, or identified geologic hazards.

6. That the applicant is committed to a development schedule demonstrating that development of the property is reasonably expected to commence within two (2) years of the initial approval of the zone change; and

Response: The zone change request is being submitted concurrently with a planned development, subdivision, and site plan review application. The applicant is committed to developing the property as soon as these applications and related site development permits are approved.

7. That the proposed development and use(s) can be developed in compliance with the applicable development standards or appropriate conditions are attached that ensure that the project development substantially conforms to the applicable development standards.

Response: This project is a single-family neighborhood, in accordance with the Frog Pond West Master Plan. Compliance with the applicable development standards of the RN zone is addressed earlier narrative.

8. Adequate public facilities, services, and transportation networks are in place, or are planned to be provided concurrently with the development of the property. The applicant shall demonstrate compliance with the Transportation Planning Rule, specifically by addressing whether the proposed amendment has a significant effect on the transportation system pursuant to OAR 660012-0060. A Traffic Impact Analysis (TIA) shall be prepared pursuant to the requirements in Section 4.133.05.(01).

Response: Adequate public facilities, services, and transportation networks are in place, or are planned to be provided concurrently with the construction of the project. The applicant will extend sewer and water infrastructure and will provide storm drainage facilities to serve the project. A Traffic Impact Analysis (TIA) was prepared by DKS Engineering at the direction of the City of Wilsonville. Compliance with the Transportation Planning Rule (TPR) is included in the Frog Pond Area Plan and assumes full development of the Frog Pond area. The Frog Pond Area Plan determined that the anticipated development within Frog Pond would comply with the TPR with the addition of a traffic signal at the intersection of Stafford Road and Frog Pond Lane. This criterion is met.

- (.05) In cases where a property owner or other applicant has requested a change in zoning and the City Council has approved the change subject to conditions, the owner or applicant shall sign a statement accepting, and agreeing to complete the conditions of approval before the zoning shall be changed.

Response: This project meets the applicable criteria as described above. The applicant will sign the statement accepting and agreeing to complete the conditions of approval, as required by this section.

CHAPTER 4. LAND DIVISIONS

Section 4.210 APPLICATION PROCEDURE

- (.01) Pre-application conference. Prior to submission of a tentative condominium, partition, or subdivision plat, a person proposing to divide land in the City shall contact the Planning Department to arrange a pre-application conference as set forth in Section 4.010.

Response: The applicant held a preapplication conference with City staff on December 12, 2019.

B. Tentative Plat Submission. The purpose of the Tentative Plat is to present a study of the proposed subdivision to the Planning Department and Development Review Board and to receive approval or recommendations for revisions before preparation of a final Plat. The design and layout of this plan plat shall meet the guidelines and requirements set forth in this Code. The Tentative Plat shall be submitted to the Planning Department with the following information:

1. Site development application form completed and signed by the owner of the land or a letter of authorization signed by the owner. A preliminary title report or other proof of ownership is to be included with the application form.
2. Application fees as established by resolution of the City Council.
3. Ten (10) copies and one (1) sepia or suitable reproducible tracing of the Tentative Plat shall be submitted with the application. Paper size shall be eighteen inch (18") by twenty-four inch (24"), or such other size as may be specified by the City Engineer.
4. Name of the subdivision. No subdivision name shall duplicate or resemble the name of any other subdivision in Clackamas or Washington County. Names may be checked through the county offices.
5. Names, addresses, and telephone numbers of the owners and applicants, and engineer or surveyor.
6. Date, north point and scale of drawing.
7. Location of the subject property by Section, Township, and Range.
8. Legal road access to subject property shall be indicated as City, County, or other public roads.
9. Vicinity map showing the relationship to the nearest major highway or street.
10. Lots: Dimensions of all lots, minimum lot size, average lot size, and proposed lot and block numbers.
11. Gross acreage in proposed plat.
12. Proposed uses of the property, including sites, if any, for multi-family dwellings, shopping centers, churches, industries, parks, and playgrounds or other public or semi-public uses.
13. Improvements: Statement of the improvements to be made or installed including streets, private drives, sidewalks, lighting, tree planting, and times such improvements are to be made or completed. [Amended by Ord. 682, 9/9/10]
14. Trees. Locations, types, sizes, and general conditions of all existing trees, as required in Section 4.600.

-
15. Utilities such as electrical, gas, telephone, on and abutting the tract.
 16. Easements: Approximate width, location, and purpose of all existing and proposed easements on, and known easements abutting the tract.
 17. Deed Restrictions: Outline of proposed deed restrictions, if any.
 18. Written Statement: Information which is not practical to be shown on the maps may be shown in separate statements accompanying the Tentative Plat.
 19. If the subdivision is to be a "Planned Development," a copy of the proposed Home Owners Association By-Laws must be submitted at the time of submission of the application. The Tentative Plat shall be considered as the Stage I Preliminary Plan. The proposed By-Laws must address the maintenance of any parks, common areas, or facilities.
 20. Any plat bordering a stream or river shall indicate areas subject to flooding and shall comply with the provisions of Section 4.172.
 21. Proposed use or treatment of any property designated as open space by the City of Wilsonville.
 22. A list of the names and addresses of the owners of all properties within 250 feet of the subject property, printed on self-adhesive mailing labels. The list shall be taken from the latest available property ownership records of the Assessor's office of the affected county.
 23. A completed "liens and assessments" form, provided by the City Finance Department.
 24. Locations of all areas designated as a Significant Resource Overlay Zone by the City, as well as any wetlands shall be shown on the tentative plat.
 25. Locations of all existing and proposed utilities, including but not limited to domestic water, sanitary sewer, storm drainage, and any private utilities crossing or intended to serve the site. Any plans to phase the construction or use of utilities shall be indicated. [Amended by Ord. 682, 9/9/10]
 26. A traffic study, prepared under contract with the City, shall be submitted as part of the tentative plat application process, unless specifically waived by the Community Development Director.

Response: The application materials include all of the information required in subsection Section 4.210(.01)B.

- D. Land division phases to be shown. Where the applicant intends to develop the land in phases, the schedule of such phasing shall be presented for review at the time of the tentative plat. In acting on an application for tentative plat approval, the Planning Director or Development Review Board may set time limits for the completion of the phasing schedule which, if not met, shall result in an expiration of the tentative plat approval.

Response: The Applicant is not proposing phased development.

- E. Remainder tracts to be shown as lots or parcels. Tentative plats shall clearly show all affected property as part of the application for land division. All

remainder tracts, regardless of size, shall be shown and counted among the parcels or lots of the division.

Response: The proposed subdivision does not create remainder tracts. The tentative plat accounts for all land within the plat area as lots, tracts, or right-of-way.

Section 4.236 GENERAL REQUIREMENTS - STREETS

(.01) Conformity to the Transportation System Plan. Land divisions shall conform to and be in harmony with the Transportation Systems Plan, the Bicycle and Pedestrian Master Plan, and the Parks and Recreation Master Plan. [Amended by Ord. #719, 6/17/13]

Response: As confirmed by the TIS, the proposed street plan conforms to the Transportation System Plan and the Frog Pond West Master Plan.

The 2006 Bicycle and Pedestrian Master Plan identifies an improvement, Community Walkway/Bikeway C10, within the site area. The 2017 Frog Pond West Master Plan incorporates a Bicycle and Pedestrian Framework (Figure 17), which identifies bicycle lanes and sidewalks along Frog Pond Lane and Stafford Road adjacent to the project frontage. The project will construct Frog Pond Lane and the bicycle/pedestrian facilities associated with it. The Stafford Road facilities will be constructed as part of the City's Stafford Road project.

(.02) Relation to Adjoining Street System.

A. A land division shall provide for the continuation of the principal streets existing in the adjoining area, or of their proper projection when adjoining property is not developed, and shall be of a width not less than the minimum requirements for streets set forth in these regulations. Where, in the opinion of the Planning Director or Development Review Board, topographic conditions make such continuation or conformity impractical, an exception may be made. In cases where the Board or Planning Commission has adopted a plan or plat of a neighborhood or area of which the proposed land division is a part, the subdivision shall conform to such adopted neighborhood or area plan.

Response: As shown on the Preliminary Street Plan (Exhibit A), the proposed street network is designed for future continuation, per the Frog Pond West Master Plan, including Tax Lots 200 and 401. These standards are met.

B. Where the plat submitted covers only a part of the applicant's tract, a sketch of the prospective future street system of the unsubmitted part shall be furnished and the street system of the part submitted shall be considered in the light of adjustments and connections with the street system of the part not submitted.

Response: The submitted tentative plat covers the entirety of the Applicant's tract.

C. At any time when an applicant proposes a land division and the Comprehensive Plan would allow for the proposed lots to be further divided, the city may require an arrangement of lots and streets such as to permit a later resubdivision in conformity to the street plans and other requirements specified in these regulations.

Response: The proposed lots follow the minimum lot size standards for R-5 and R-7 designations and will not be further subdivided.

(.03) All streets shall conform to the standards set forth in Section 4.177 and the block size requirements of the zone.

Response: Compliance with the standards of Section 4.177 is addressed earlier in the narrative.

(.04) **Creation of Easements:** The Planning Director or Development Review Board may approve an easement to be established without full compliance with these regulations, provided such an easement is the only reasonable method by which a portion of a lot large enough to allow partitioning into two (2) parcels may be provided with vehicular access and adequate utilities. If the proposed lot is large enough to divide into more than two (2) parcels, a street dedication may be required. [Amended by Ord. 682, 9/9/10]

Response: The Applicant is not requesting street easements.

(.05) **Topography:** The layout of streets shall give suitable recognition to surrounding topographical conditions in accordance with the purpose of these regulations.

Response: The street layout recognizes topographical conditions.

(.06) **Reserve Strips:** The Planning Director or Development Review Board may require the applicant to create a reserve strip controlling the access to a street. Said strip is to be placed under the jurisdiction of the City Council, when the Director or Board determine that a strip is necessary:

- A. To prevent access to abutting land at the end of a street in order to assure the proper extension of the street pattern and the orderly development of land lying beyond the street; or
- B. To prevent access to the side of a street on the side where additional width is required to meet the right-of-way standards established by the City; or
- C. To prevent access to land abutting a street of the land division but not within the tract or parcel of land being divided; or
- D. To prevent access to land unsuitable for building development.

Response: The project does not include reserve strips.

(.07) **Future Expansion of Street:** When necessary to give access to, or permit a satisfactory future division of, adjoining land, streets shall be extended to the boundary of the land division and the resulting dead-end street may be approved without a turn-around. Reserve strips and street plugs shall be required to preserve the objective of street extension. Notification that the street is planned for future extension shall be posted on the stub street. [Amended by Ord. #719, 6/17/13]

Response: Local Trillium Street and Windflower Street are designed to extend to the boundaries of the site and are intended for future extension. For that reason, no turnarounds are proposed for these streets. The Applicant will comply with any requirements related to signage street extension objectives. This standard is met.

(.08) **Existing Streets:** Whenever existing streets adjacent to or within a tract are of inadequate width, additional right-of-way shall conform to the designated width in this Code or in the Transportation Systems Plan.

Response: The project will dedicate 12 feet of right-of-way to Stafford Road and 10 feet of right-of-way to Kahle Road for the future expansion. The project also dedicates 21.5 feet of right-of-way to Frog Pond Lane and will construct the remaining width of this street simultaneously with the construction of the Frog Pond Crossing neighborhood.

-
- (.09) **Street Names:** No street names will be used which will duplicate or be confused with the names of existing streets, except for extensions of existing streets. Street names and numbers shall conform to the established name system in the City, and shall be subject to the approval of the City Engineer.

Response: Local streets (Marigold Terrace, Windflower Street, Trillium Street, Yarrow Lane) and the Private Alley (Tract B) will conform to the City's established name system and will be subject to approval by the City Engineer. This standard is met.

Section 4.237 **GENERAL REQUIREMENTS – OTHER.**

(.01) **Blocks:**

- A. The length, width, and shape of blocks shall be designed with due regard to providing adequate building sites for the use contemplated, consideration of needs for convenient access, circulation, control, and safety of pedestrian, bicycle, and motor vehicle traffic, and recognition of limitations and opportunities of topography.
- B. **Sizes:** Blocks shall not exceed the sizes and lengths specified for the zone in which they are located unless topographical conditions or other physical constraints necessitate larger blocks. Larger blocks shall only be approved where specific findings are made justifying the size, shape, and configuration.

Response: The length, width, and shape of blocks have been designed to accommodate the development established by the Frog Pond West Master Plan and to comply with the standards of Section 4.177. These standards are addressed above. The site is located within the RN zone and is also subject to the block, access, and connectivity standards of Section 4.127(.10). Those standards are addressed above.

(.02) **Easements:**

- A. **Utility lines.** Easements for sanitary or storm sewers, drainage, water mains, electrical lines or other public utilities shall be dedicated wherever necessary. Easements shall be provided consistent with the City's Public Works Standards, as specified by the City Engineer or Planning Director. All of the public utility lines within and adjacent to the site shall be installed within the public right-of-way or easement; with underground services extending to the private parcel constructed in conformance to the City's Public Works Standards. All franchise utilities shall be installed within a public utility easement. All utilities shall have appropriate easements for construction and maintenance purposes. [Amended by Ord. 682, 9/9/10]
- B. **Water courses.** Where a land division is traversed by a water course, drainage way, channel or stream, there shall be provided a storm water easement or drainage right-of-way conforming substantially with the lines of the water course, and such further width as will be adequate for the purposes of conveying storm water and allowing for maintenance of the facility or channel. Streets or parkways parallel to water courses may be required.

Response: Public utilities are placed within public rights-of-way or within public utility easements (PUE) adjacent to the public streets. The tentative plat shows a public access and utility easement (PAUE) over the private alley/Tract B.

- (.03) **Pedestrian and bicycle pathways.** An improved public pathway shall be required to transverse the block near its middle if that block exceeds the length standards of the zone in which it is located.

-
- A. Pathways shall be required to connect to cul-de-sacs or to pass through unusually shaped blocks.
 - B. Pathways required by this subsection shall have a minimum width of ten (10) feet unless they are found to be unnecessary for bicycle traffic, in which case they are to have a minimum width of six (6) feet.

Response: There is one block that exceeds the maximum block length of 330 feet. As discussed above, a pedestrian connection with a ten-foot-wide paved pathway is proposed running north/south through that block to provide connectivity between Trillium Street and Windflower Street. Additionally, pathways are proposed for a pedestrian connection between local Trillium Street and BPA Open Space. These standards are met.

- (.04) Tree planting. Tree planting plans for a land division must be submitted to the Planning Director and receive the approval of the Director or Development Review Board before the planting is begun. Easements or other documents shall be provided, guaranteeing the City the right to enter the site and plant, remove, or maintain approved street trees that are located on private property.

Response: Proposed tree planting is shown on the Preliminary Landscape Plan (Exhibit A). Proposed street trees are located within public right-of-way planter strips and additional easements are not required.

- (.05) Lot Size and shape. The lot size, width, shape and orientation shall be appropriate for the location of the land division and for the type of development and use contemplated. Lots shall meet the requirements of the zone where they are located.
 - A. In areas that are not served by public sewer, an on-site sewage disposal permit is required from the City. If the soil structure is adverse to on-site sewage disposal, no development shall be permitted until sewer service can be provided.
 - B. Where property is zoned or deeded for business or industrial use, other lot widths and areas may be permitted at the discretion of the Development Review Board. Depth and width of properties reserved or laid out for commercial and industrial purposes shall be adequate to provide for the off-street service and parking facilities required by the type of use and development contemplated.
 - C. In approving an application for a Planned Development, the Development Review Board may waive the requirements of this section and lot size, shape, and density shall conform to the Planned Development conditions of approval.

Response: The site is served by public sewer and no on-site sewage disposal is proposed. The property is zoned for residential use and is subject to an application for a Planned Development. The site is located within the RN zone and is subject to the standards of that zone. The proposed lots meet the dimensional standards of the RN zone and the R-7 and R-5 designations, with the allowed lot size reduction for the purpose of open space preservation in a PUD. Please refer to response under WDC Section 4.127(.08). These standards are met.

- (.06) Access. The division of land shall be such that each lot shall have a minimum frontage on a street or private drive, as specified in the standards of the relative zoning districts. This minimum frontage requirement shall apply with the following exceptions:

-
- A. A lot on the outer radius of a curved street or tract with a private drive, or facing the circular end of a cul-de-sac shall have frontage of not less than twenty-five (25) feet upon a street or tract with a private drive, measured on the arc.
 - B. The Development Review Board may waive lot frontage requirements where in its judgment the waiver of frontage requirements will not have the effect of nullifying the intent and purpose of this regulation or if the Board determines that another standard is appropriate because of the characteristics of the overall development.

[Section 4.237(.06) amended by Ord. 682, 9/9/10]

Response: The minimum lot width in the RN zone R-5 and R-7 designations is 35 feet. As shown on the Preliminary Subdivision Plan (Exhibit A), the lots meet the dimensional standards. The applicant is requesting a waiver for public street frontage for lots 17 – 24 in order to accommodate preservation of a mature Oregon White Oak tree grove. Eight single-family lots will have frontage on common open space with pedestrian pathways and legal lot access via a private alley. This project is a PUD, which allows certain flexibility with design in order to encourage preservation of natural resources. The Development Review Board can make a finding that the lot frontage requirement can be waived in the interest of a greater public benefit and an asset to the community in the form of additional usable open space, without nullifying the intent of the regulation. Please refer to the response to Section 4.127 earlier in the narrative.

(.07) Through lots. Through lots shall be avoided except where essential to provide separation of residential development from major traffic arteries or adjacent non-residential activity or to overcome specific disadvantages of topography and orientation. A planting screen easement of at least ten (10) feet, across which there shall be no access, may be required along the line of lots abutting such a traffic artery or other disadvantageous use. Through lots with planting screens shall have a minimum average depth of one hundred (100) feet. The Development Review Board may require assurance that such screened areas be maintained as specified in Section 4.176.

Response: No through lots are proposed. This standard is not applicable.

(.08) Lot side lines. The side lines of lots, as far as practicable for the purpose of the proposed development, shall run at right angles to the street or tract with a private drive upon which the lots face. [Amended by Ord. 682, 9/9/10]

Response: All side lot lines run at right angles to the street or the tract upon which they face. This standard is met.

(.09) Large lot land divisions. In dividing tracts which at some future time are likely to be re-divided, the location of lot lines and other details of the layout shall be such that re-division may readily take place without violating the requirements of these regulations and without interfering with the orderly development of streets. Restriction of buildings within future street locations shall be made a matter of record if the Development Review Board considers it necessary.

Response: No future development tracts are proposed in this application.

-
- (.10) **Building line.** The Planning Director or Development Review Board may establish special building setbacks to allow for the future redivision or other development of the property or for other reasons specified in the findings supporting the decision. If special building setback lines are established for the land division, they shall be shown on the final plat.

Response: No special building setbacks are proposed.

- (.11) **Build-to line.** The Planning Director or Development Review Board may establish special build-to lines for the development, as specified in the findings and conditions of approval for the decision. If special build-to lines are established for the land division, they shall be shown on the final plat.

Response: There is no maximum setback in the RN zone and no build-to lines are proposed.

- (.12) **Land for public purposes.** The Planning Director or Development Review Board may require property to be reserved for public acquisition, or irrevocably offered for dedication, for a specified period of time.

Response: The City has not identified any requirements for property to be reserved for public acquisition. The development will dedicate right-of-way for the public street network.

- (.13) **Corner lots.** Lots on street intersections shall have a corner radius of not less than ten (10) feet.

Response: As shown on the Preliminary Street Plan (Exhibit A), lots on street intersections have corner radii of at least 10 feet. This standard is met.

Section 4.250 LOTS OF RECORD

All lots of record that have been legally created prior to the adoption of this ordinance shall be considered to be legal lots. Tax lots created by the County Assessor are not necessarily legal lots of record.

Response: The application contains documents confirming that all subject lots are lots of record.

Section 4.262 IMPROVEMENTS - REQUIREMENTS

- (.01) **Streets.** Streets within or partially within the development shall be graded for the entire right-of-way width, constructed and surfaced in accordance with the Transportation Systems Plan and City Public Works Standards. Existing streets which abut the development shall be graded, constructed, reconstructed, surfaced or repaired as determined by the City Engineer.
- (.02) **Curbs.** Curbs shall be constructed in accordance with standards adopted by the City.
- (.03) **Sidewalks.** Sidewalks shall be constructed in accordance with standards adopted by the City.

Response: As shown on the Preliminary Street Plan (Exhibit A), streets will be graded, constructed, and surfaced according to the TSP, the cross-sections incorporated into the Frog Pond West Master Plan, and the City's Public Works Standards as modified by the City Engineer. These standards are met.

- (.04) **Sanitary sewers.** When the development is within two hundred (200) feet of an existing public sewer main, sanitary sewers shall be installed to serve each lot or parcel in accordance with standards adopted by the City. When the development is more than two hundred (200) feet from an existing public sewer main, the City Engineer may approve an alternate sewage disposal system.

Response: As shown on the Preliminary Composite Utility Plan (Exhibit A), the project connects to existing public sanitary sewer main at SW Frog Pond Lane and SW Marigold Terrace and serves each lot in accordance with standards adopted by the City.

(.05) **Drainage.** Storm drainage, including detention or retention systems, shall be provided as determined by the City Engineer.

Response: Storm drainage systems are being provided as outlined in the City's Public Works Standards. These requirements are met.

(.06) **Underground utility and service facilities.** All new utilities shall be subject to the standards of Section 4.300 (Underground Utilities). The developer shall make all necessary arrangements with the serving utility to provide the underground services in conformance with the City's Public Works Standards.

Response: The standards of Section 4.300 are addressed earlier in the narrative. These standards are met.

(.07) **Streetlight standards.** Streetlight standards shall be installed in accordance with regulations adopted by the City.

Response: Streetlights will be installed per the Frog Pond West Master Plan and regulations adopted by the City.

(.08) **Street signs.** Street name signs shall be installed at all street intersections and dead-end signs at the entrance to all dead-end streets and cul-de-sacs in accordance with standards adopted by the City. Other signs may be required by the City Engineer.

Response: Street signs will be installed per City standards.

(.09) **Monuments.** Monuments shall be placed at all lot and block corners, angle points, points of curves in streets, at intermediate points and shall be of such material, size and length as required by State Law. Any monuments that are disturbed before all improvements are completed by the developer and accepted by the City shall be replaced to conform to the requirements of State Law.

Response: Monuments will be placed per State, Clackamas County, and City requirements.

(.10) **Water.** Water mains and fire hydrants shall be installed to serve each lot in accordance with City standards.

Response: Water mains and fire hydrants are proposed to serve each lot in accordance with City and Fire Department standards. Please refer to the Preliminary Composite Utility Plan (Exhibit A).

CHAPTER 4. UNDERGROUND UTILITIES.

Section 4.300 GENERAL

(.02) After the effective date of this Code, the approval of any development of land within the City will be upon the express condition that all new utility lines, including but not limited to those required for power, communication, street lighting, gas, cable television services and related facilities, shall be placed underground.

(.03) The construction of underground utilities shall be subject to the City's Public Works Standards and shall meet applicable requirements for erosion control and other environmental protection.

Response: The project is subject to the requirements of this section.

Section 4.320 REQUIREMENTS

-
- (.01) The developer or subdivider shall be responsible for and make all necessary arrangements with the serving utility to provide the underground services (including cost of rearranging any existing overhead facilities). All such underground facilities as described shall be constructed in compliance with the rules and regulations of the Public Utility Commission of the State of Oregon relating to the installation and safety of underground lines, plant, system, equipment and apparatus.
 - (.02) The location of the buried facilities shall conform to standards supplied to the subdivider by the City. The City also reserves the right to approve location of all surface-mounted transformers.
 - (.03) Interior easements (back lot lines) will only be used for storm or sanitary sewers, and front easements will be used for other utilities unless different locations are approved by the City Engineer. Easements satisfactory to the serving utilities shall be provided by the developer and shall be set forth on the plat.

Response: New utilities will be installed underground in accordance with City and other agency requirements.

CHAPTER 4. SITE DESIGN REVIEW

Section 4.421 CRITERIA AND APPLICATION OF DESIGN STANDARDS

- (.01) The following standards shall be utilized by the Board in reviewing the plans, drawings, sketches and other documents required for Site Design Review. These standards are intended to provide a frame of reference for the applicant in the development of site and building plans as well as a method of review for the Board. These standards shall not be regarded as inflexible requirements. They are not intended to discourage creativity, invention and innovation. The specifications of one or more particular architectural styles is not included in these standards. (Even in the Boones Ferry Overlay Zone, a range of architectural styles will be encouraged.)
 - A. Preservation of Landscape. The landscape shall be preserved in its natural state, insofar as practicable, by minimizing tree and soils removal, and any grade changes shall be in keeping with the general appearance of neighboring developed areas.

Response: Tract A includes BPA easement/open space corridor which contain a wetland and mature oak trees. Site design incorporates preservation of landscape to the greatest degree practicable.

- B. Relation of Proposed Buildings to Environment. Proposed structures shall be located and designed to assure harmony with the natural environment, including protection of steep slopes, vegetation and other naturally sensitive areas for wildlife habitat and shall provide proper buffering from less intensive uses in accordance with Sections 4.171 and 4.139 and 4.139.5. The achievement of such relationship may include the enclosure of space in conjunction with other existing buildings or other proposed buildings and the creation of focal points with respect to avenues of approach, street access or relationships to natural features such as vegetation or topography.

Response: The project layout is considerate to the natural features of the site. The existing wetland in the northeast corner of the site is left undisturbed and provides shelter for wildlife and passive recreational opportunities for the residents. A 12-foot landscape strip with a brick wall provides appropriate buffering for the single-family homes along Stafford Road, an arterial street, from the light and noise generated by traffic. Homes were located on the site to avoid a grove of mature Oregon White Oak trees along the northwestern edge of

the site and a pedestrian path is placed along the tree grove for residents to enjoy this natural feature.

- C. **Drives, Parking and Circulation.** With respect to vehicular and pedestrian circulation, including walkways, interior drives and parking, special attention shall be given to location and number of access points, general interior circulation, separation of pedestrian and vehicular traffic, and arrangement of parking areas that are safe and convenient and, insofar as practicable, do not detract from the design of proposed buildings and structures and the neighboring properties.

Response: The drives, parking, and circulation within the development are subject to the requirements of the RN Zone, the Planned Development overlay, and Land Division requirements and are not subject to Site Design Review. This standard is not applicable.

- D. **Surface Water Drainage.** Special attention shall be given to proper site surface drainage so that removal of surface waters will not adversely affect neighboring properties of the public storm drainage system.

Response: Please refer to Exhibit G for the Preliminary Stormwater Report. The Preliminary Street Plan (Exhibit A) shows the location of Low Impact Development Approaches (LIDA) facilities within the planter strips of the public streets and the stormwater facility within Tract A.

- E. **Utility Service.** Any utility installations above ground shall be located so as to have a harmonious relation to neighboring properties and site. The proposed method of sanitary and storm sewage disposal from all buildings shall be indicated.

Response: As shown on the Preliminary Composite Utility Plan (Exhibit A), each lot will be served by a sanitary sewer line. Storm sewage disposal is provided by a storm drain system connecting to each on-site stormwater facility.

- (.02) **The standards of review outlined in Sections (a) through (g) above shall also apply to all accessory buildings, structures, exterior signs and other site features, however related to the major buildings or structures.**

Response: This application does not include accessory buildings or exterior signs.

- (.04) **Conditional application. The Planning Director, Planning Commission, Development Review Board or City Council may, as a Condition of Approval for a zone change, subdivision, land partition, variance, conditional use, or other land use action, require conformance to the site development standards set forth in this Section.**

Response: This application includes a zone change and planned development, among other applications, and includes responses to the site development standards of those sections. Per City staff, the project elements subject to Site Design Review and the standards of this chapter are tracts and their landscaping, landscaping in the public right-of-way, and the Stafford Road wall.

-
- (.05) The Board may attach certain development or use conditions in granting an approval that are determined necessary to insure the proper and efficient functioning of the development, consistent with the intent of the Comprehensive Plan, allowed densities and the requirements of this Code. In making this determination of compliance and attaching conditions, the Board shall, however, consider the effects of this action on the availability and cost of needed housing. The provisions of this section shall not be used in such a manner that additional conditions either singularly or accumulatively have the effect of unnecessarily increasing the cost of housing or effectively excluding a needed housing type.

Response: This single-family community has been designed in accordance with the Frog Pond West Master Plan, which is part of, and consistent with, the Comprehensive Plan. The site plan is consistent with allowable number of homes and other requirements established by the Frog Pond West Master Plan and the implementing RN zone. No additional conditions are needed to ensure that the project remains consistent with the City's adopted policies.

- (.06) The Board or Planning Director may require that certain paints or colors of materials be used in approving applications. Such requirements shall only be applied when site development or other land use applications are being reviewed by the City.
- A. Where the conditions of approval for a development permit specify that certain paints or colors of materials be used, the use of those paints or colors shall be binding upon the applicant. No Certificate of Occupancy shall be granted until compliance with such conditions has been verified.
 - B. Subsequent changes to the color of a structure shall not be subject to City review unless the conditions of approval under which the original colors were set included a condition requiring a subsequent review before the colors could be changed.

Response: This project is a detached single-family community. No paints or colors of materials are identified in the design standards of the Frog Pond West Master Plan. It is anticipated that building elevations, including paint and material colors, will be evaluated at the time of building permit review.

Section 4.440 PROCEDURE

- (.01) Submission of Documents. A prospective applicant for a building or other permit who is subject to site design review shall submit to the Planning Department, in addition to the requirements of Section 4.035, the following:
- A. A site plan, drawn to scale, showing the proposed layout of all structures and other improvements including, where appropriate, driveways, pedestrian walks, landscaped areas, fences, walls, offstreet parking and loading areas, and railroad tracks. The site plan shall indicate the location of entrances and exits and direction of traffic flow into and out of off-street parking and loading areas, the location of each parking space and each loading berth and areas of turning and maneuvering vehicles. The site plan shall indicate how utility service and drainage are to be provided.

Response: The Preliminary Plans (Exhibit A) provide the information listed above, as applicable.

- B. A Landscape Plan, drawn to scale, showing the location and design of landscaped areas, the variety and sizes of trees and plant materials to be planted on the site, the location and design of landscaped areas, the varieties, by scientific and common name, and sizes of trees and plant materials to be retained or planted on the site, other pertinent landscape features, and irrigation systems required to maintain trees and plant materials. An inventory, drawn at the same scale as the Site Plan, of existing trees of 4"

caliper or more is required. However, when large areas of trees are proposed to be retained undisturbed, only a survey identifying the location and size of all perimeter trees in the mass is necessary.

Response: The Preliminary Landscape Plan and Preliminary Tree Preservation and Removal Plan (Exhibit A) are included with this application. The plans provide the information required in section.

- C. Architectural drawings or sketches, drawn to scale, including floor plans, in sufficient detail to permit computation of yard requirements and showing all elevations of the proposed structures and other improvements as they will appear on completion of construction. Floor plans shall also be provided in sufficient detail to permit computation of yard requirements based on the relationship of indoor versus outdoor living area, and to evaluate the floor plan's effect on the exterior design of the building through the placement and configuration of windows and doors.

Response: Example building elevations and floor plans are included as Exhibit M.

- D. A Color Board displaying specifications as to type, color, and texture of exterior surfaces of proposed structures. Also, a phased development schedule if the development is constructed in stages.
- E. A sign Plan, drawn to scale, showing the location, size, design, material, color and methods of illumination of all exterior signs.
- F. The required application fee.

Response: A color board is not included, as exterior dwelling design will be evaluated at the time of building permit review. No signs are proposed at this time. The required application fee has been submitted with this application.

CHAPTER 4. TREE PRESERVATION AND PROTECTION

Section 4.600.30 TREE REMOVAL PERMIT REQUIRED

- (.01) Requirement Established. No person shall remove any tree without first obtaining a Tree Removal Permit (TRP) as required by this subchapter.
- (.02) Tree Removal Permits will be reviewed according to the standards provided for in this subchapter, in addition to all other applicable requirements of Chapter 4.
- (.03) Although tree activities in the Willamette River Greenway are governed by WC 4.500 - 4.514, the application materials required to apply for a conditional use shall be the same as those required for a Type B or C permit under this subchapter, along with any additional materials that may be required by the Planning Department. An application for a Tree Removal Permit under this section shall be reviewed by the Development Review Board.

Response: As shown on the Preliminary Tree Protection and Removal Plan included in Exhibit A, the development will remove trees and a Tree Removal Permit is required.

Section 4.600.50 APPLICATION FOR TREE REMOVAL PERMIT

- (.01) Application for Permit. A person seeking to remove one or more trees shall apply to the Director for a Tree Removal Permit for a Type A, B, C, or D permit, depending on the applicable standards as provided in this subchapter.
 - A. An application for a tree removal permit that does not meet the requirements of Type A may be submitted as a Type B application.

-
- (.02) Time of Application. Application for a Tree Removal Permit shall be made before removing or transplanting trees, except in emergency situations as provided in WC 4.600.40 (1)(B) above. Where the site is proposed for development necessitating site plan or plat review, application for a Tree Removal Permit shall be made as part of the site development application as specified in this subchapter.
 - (.03) Fees. A person applying for a Tree Removal Permit shall pay a non-refundable application fee; as established by resolution of the City Council.
 - A. By submission of an application, the applicant shall be deemed to have authorized City representatives to have access to applicant's property as may be needed to verify the information provided, to observe site conditions, and if a permit is granted, to verify that terms and conditions of the permit are followed.

Response: The project application includes a Type C Removal Plan for Design Review Board review and approval. A Type C Tree Removal Permit will be obtained prior to commencement of construction.

Section 4.610.00 APPLICATION REVIEW PROCEDURE

- (.01) The permit applicant shall provide complete information as required by this subchapter in order for the City to review the application.
- (.02) Departmental Review. All applications for Tree Removal Permits must be deemed complete by the City Planning Department before being accepted for review. When all required information has been supplied, the Planning Department will verify whether the application is complete. Upon request of either the applicant or the City, the City may conduct a field inspection or review meeting. City departments involved in the review shall submit their report and recommendations to the Planning Director who shall forward them to the appropriate reviewing authority.
- (.03) Reviewing Authority.
 - A. Type A or B. Where site plan review or plat approval by the Development Review Board is not required by City ordinance, the grant or denial of the Tree Removal Permit application shall be the responsibility of the Planning Director. The Planning Director has the authority to refer a Type B permit application to the DRB under the Class II administrative review procedures of this Chapter. The decision to grant or deny a permit shall be governed by the applicable review standards enumerated in WC 4.610.10
 - B. Type C. Where the site is proposed for development necessitating site plan review or plat approval by the Development Review Board, the Development Review Board shall be responsible for granting or denying the application for a Tree Removal Permit, and that decision may be subject to affirmance, reversal or modification by the City Council, if subsequently reviewed by the Council.
 - C. Type D. Type D permit applications shall be subject to the standards and procedures of Class I administrative review and shall be reviewed for compliance with the Oregon Forest Practice Rules and Statutes. The Planning Director shall make the decision to grant or deny an application for a Type D permit.
 - D. Review period for complete applications. Type A permit applications shall be reviewed within 10 (ten) working days. Type B permit applications shall be reviewed by the Planning Director within thirty (30) calendar days, except that the DRB shall review any referred application within sixty (60) calendar days. Type C permit applications shall be reviewed within the time frame

established by this Chapter. Type D permit applications shall be reviewed within 15 calendar days.

Response: The application is for a Type C Tree Removal Plan and is subject to review and approval by the DRB.

Section 4.610.10 STANDARDS FOR TREE REMOVAL, RELOCATION OR REPLACEMENT

(.01) Except where an application is exempt, or where otherwise noted, the following standards shall govern the review of an application for a Type A, B, C or D Tree Removal Permit:

[...]

- B. **Preservation and Conservation.** No development application shall be denied solely because trees grow on the site. Nevertheless, tree preservation and conservation as a design principle shall be equal in concern and importance to other design principles.
- C. **Developmental Alternatives.** Preservation and conservation of wooded areas and trees shall be given careful consideration when there are feasible and reasonable location alternatives and design options on-site for proposed buildings, structures or other site improvements.

Response: The site layout is based on and limited by factors such as allowable residential densities, lot dimensional standards, and circulation network established in the Frog Pond West Mater Plan. The existing trees are planned to be preserved to the greatest extent practicable while meeting the objectives of the project and meeting the Development Code requirements. This standard is met.

- D. **Land Clearing.** Where the proposed activity requires land clearing, the clearing shall be limited to designated street rights-of-way and areas necessary for the construction of buildings, structures or other site improvements.

Response: The proposed land clearing is limited to designated street rights-of-way and areas necessary for the construction of single-family homes. This standard is met.

- E. **Residential Development.** Where the proposed activity involves residential development, residential units shall, to the extent reasonably feasible, be designed and constructed to blend into the natural setting of the landscape.

Response: This project is a single-family residential neighborhood. The homes will be designed and constructed, as much as possible, to blend into the natural areas on the site. This standard is met.

- F. **Compliance with Statutes and Ordinances.** The proposed activity shall comply with all applicable statutes and ordinances.

Response: Applicable statutes and ordinances include the City's Development Code. The proposed activity will comply with this code and any other applicable statutes and ordinances. This standard is met.

- G. **Relocation or Replacement.** The proposed activity shall include necessary provisions for tree relocation or replacement, in accordance with WC 4.620.00, and the protection of those trees that are not to be removed, in accordance with WC 4.620.10.

Response: As shown on the Preliminary Tree Protection and Removal Plan, trees to be retained will be protected per the provisions of 4.620.10 and trees will be replaced in accordance with 4.620.00. Those provisions are addressed in the responses to WDC Section 4.620 later in this narrative. This standard is met.

H. **Limitation.** Tree removal or transplanting shall be limited to instances where the applicant has provided completed information as required by this Chapter and the reviewing authority determines that removal or transplanting is necessary based on the criteria of this subsection.

1. **Necessary For Construction.** Where the applicant has shown to the satisfaction of the reviewing authority that removal or transplanting is necessary for the construction of a building, structure or other site improvement, and that there is no feasible and reasonable location alternative or design option on-site for a proposed building, structure or other site improvement; or a tree is located too close to existing or proposed buildings or structures, or creates unsafe vision clearance.

Response: As shown on the Preliminary Tree Preservation and Removal Plan (Exhibit A) and the associated Table included in the Preliminary Plans (Exhibit A), there are 34 existing trees on site, 3 line trees, and 24 offsite trees. Of those trees, 22 are in poor or declining condition. Removal of 38 trees is necessary for construction of site improvements, including utilities, stormwater pond, public streets, and single-family homes. The location of public streets and connections, as well as minimum and maximum residential density and dimensional standards of residential lots are determined by the requirements of the Frog Pond West Master Plan. The construction of this project is anticipated by the Frog Pond West Master Plan. The trees will be replaced onsite with a variety of native trees that will be planted in the open space tract. Additionally, street trees in the right-of-way planter strips will serve to soften the urban environment, contribute to stormwater management, and provide shade and protection for pedestrians.

2. **Disease, Damage, or Nuisance, or Hazard.** Where the tree is diseased, damaged, or in danger of falling, or presents a hazard as defined in WC 6.208, or is a nuisance as defined in WC 6.200 et seq., or creates unsafe vision clearance as defined in this Code.

(a) As a condition of approval of Stage II development, filbert trees must be removed if they are no longer commercially grown or maintained.

3. **Interference.** Where the tree interferes with the healthy growth of other trees, existing utility service or drainage, or utility work in a previously dedicated right-of-way, and it is not feasible to preserve the tree on site.

4. **Other.** Where the applicant shows that tree removal or transplanting is reasonable under the circumstances.

I. **Additional Standards for Type C Permits.**

1. **Tree survey.** For all site development applications reviewed under the provisions of Chapter 4 Planning and Zoning, the developer shall provide a Tree Survey before site development as required by WC 4.610.40, and provide a Tree Maintenance and Protection plan, unless specifically exempted by the Planning Director or DRB, prior to initiating site development.

Response: A tree survey has been completed and incorporated into the Tree Removal and Protection Plan (Exhibit A). This standard is met.

2. **Platted Subdivisions.** The recording of a final subdivision plat whose preliminary plat has been reviewed and approved after the effective date of Ordinance 464 by the City and that conforms with this subchapter shall include a Tree Survey and Maintenance and Protection Plan, as required by this subchapter, along with all other conditions of approval.

Response: This application includes a preliminary subdivision plat (Exhibit A). Following the approval of this application, the applicant will submit a final subdivision plat, which will include a Tree Survey and Maintenance Protection Plan (Exhibit A), pursuant to the Code requirements. This standard is met

3. **Utilities.** The City Engineer shall cause utilities to be located and placed wherever reasonably possible to avoid adverse environmental consequences given the circumstances of existing locations, costs of placement and extensions, the public welfare, terrain, and preservation of natural resources. Mitigation and/or replacement of any removed trees shall be in accordance with the standards of this subchapter.

Response: The utilities will be located and placed within rights-of-way or adjacent PUEs whenever possible. Trees removed from the site will be mitigated and/or replaced per the provisions of 4.620.00. This standard is met.

[...]

Section 4.610.40 TYPE C PERMIT

- (.01) Approval to remove any trees on property as part of a site development application may be granted in a Type C permit. A Type C permit application shall be reviewed by the standards of this subchapter and all applicable review criteria of Chapter 4. Application of the standards of this section shall not result in a reduction of square footage or loss of density, but may require an applicant to modify plans to allow for buildings of greater height. If an applicant proposes to remove trees and submits a landscaping plan as part of a site development application, an application for a Tree Removal Permit shall be included. The Tree Removal Permit application will be reviewed in the Stage II development review process, and any plan changes made that affect trees after Stage II review of a development application shall be subject to review by DRB. Where mitigation is required for tree removal, such mitigation may be considered as part of the landscaping requirements as set forth in this Chapter. Tree removal shall not commence until approval of the required Stage II application and the expiration of the appeal period following that decision. If a decision approving a Type C permit is appealed, no trees shall be removed until the appeal has been settled.

Response: As described above, removal of 38 trees is necessary for construction associated with this site development application. The project earns a credit for 9 trees through preservation of existing mature Oregon White Oaks. A Preliminary Landscape Plan and an application for a Tree Removal Permit are included in this application. The Preliminary Landscape Plan (Exhibit A) indicates 29 mitigation trees will be planted in the open space tract, in addition to 26 street trees in the public rights-of-way.

- (.02) The applicant must provide ten copies of a Tree Maintenance and Protection Plan completed by an arborist that contains the following information:

-
- A. A plan, including a topographical survey bearing the stamp and signature of a qualified, registered professional containing all the following information:
1. Property Dimensions. The shape and dimensions of the property, and the location of any existing and proposed structure or improvement.
 2. Tree survey. The survey must include:
 - a. An accurate drawing of the site based on accurate survey techniques at a minimum scale of one inch (1") equals one hundred feet (100') and which provides a) the location of all trees having six inches (6") or greater d.b.h. likely to be impacted, b) the spread of canopy of those trees, (c) the common and botanical name of those trees, and d) the approximate location and name of any other trees on the property.
 - b. A description of the health and condition of all trees likely to be impacted on the site property. In addition, for trees in a present or proposed public street or road right-of-way that are described as unhealthy, the description shall include recommended actions to restore such trees to full health. Trees proposed to remain, to be transplanted or to be removed shall be so designated. All trees to remain on the site are to be designated with metal tags that are to remain in place throughout the development. Those tags shall be numbered, with the numbers keyed to the tree survey map that is provided with the application.
 - c. Where a stand of twenty (20) or more contiguous trees exist on a site and the applicant does not propose to remove any of those trees, the required tree survey may be simplified to accurately show only the perimeter area of that stand of trees, including its drip line. Only those trees on the perimeter of the stand shall be tagged, as provided in "b," above.
 - d. All Oregon white oaks, native yews, and any species listed by either the state or federal government as rare or endangered shall be shown in the tree survey.
 3. Tree Protection. A statement describing how trees intended to remain will be protected during development, and where protective barriers are necessary, that they will be erected before work starts. Barriers shall be sufficiently substantial to withstand nearby construction activities. Plastic tape or similar forms of markers do not constitute "barriers."
 4. Easements and Setbacks. Location and dimension of existing and proposed easements, as well as all setbacks required by existing zoning requirements.
 5. Grade Changes. Designation of grade changes proposed for the property that may impact trees.
 6. Cost of Replacement. A cost estimate for the proposed tree replacement program with a detailed explanation including the number, size and species.

-
7. **Tree Identification.** A statement that all trees being retained will be identified by numbered metal tags, as specified in subsection "A," above in addition to clear identification on construction documents.

Response: A Preliminary Tree Preservation and Removal Plan is included in the preliminary plans (Exhibit A). It includes a tree survey indicating the location of trees greater than 6-inch diameter at breast height (DBH), information about the condition of the trees, crown diameter, and proposed action for each tree. The plan also includes a statement identifying the purpose of the tree tags. Please refer to the Preliminary Existing Conditions Plan (Exhibit A) prepared by a professional surveyor for the location of existing structures and improvements. Please refer to the Preliminary Dimensioned Subdivision Plan for the location of proposed improvements and setbacks. Since tree replacement requirement is fully satisfied onsite, payment into the tree replacement fund is not proposed, therefore the cost estimate requirement is not applicable.

Section 4.620.00 TREE RELOCATION, MITIGATION, OR REPLACEMENT

- (.01) **Requirement Established.** A Type B or C Tree Removal Permit grantee shall replace or relocate each removed tree having six (6) inches or greater d.b.h. within one year of removal.
- (.02) **Basis for Determining Replacement.** The permit grantee shall replace removed trees on a basis of one (1) tree replanted for each tree removed. All replacement trees must measure two inches (2") or more in diameter. Alternatively, the Planning Director or Development Review Board may require the permit grantee to replace removed trees on a per caliper inch basis, based on a finding that the large size of the trees being removed justifies an increase in the replacement trees required. Except, however, that the Planning Director or Development Review Board may allow the use of replacement Oregon white oaks and other uniquely valuable trees with a smaller diameter.

Response: The Preliminary Landscape Plan (Exhibit A) includes replacement trees at a 1:1 ratio. Project construction requires removal of 38 trees. As outlined in the response to WDC Section 4.176(.06)F, the project earns a credit for 9 trees through preservation of existing mature trees, thus 29 trees are required to be replaced. There are 29 replacement trees proposed to be planted in Open Space Tract A, in addition to 26 street trees. All replacement trees measure minimum 2 inch in diameter.

- (.03) **Replacement Tree Requirements.** A mitigation or replacement tree plan shall be reviewed by the City prior to planting and according to the standards of this subsection.
- A. Replacement trees shall have shade potential or other characteristics comparable to the removed trees, shall be appropriately chosen for the site from an approved tree species list supplied by the City, and shall be state Department of Agriculture Nursery Grade No. 1 or better.
- B. Replacement trees must be staked, fertilized and mulched, and shall be guaranteed by the permit grantee or the grantee's successors-in-interest for two (2) years after the planting date.
- C. A "guaranteed" tree that dies or becomes diseased during that time shall be replaced.
- D. Diversity of tree species shall be encouraged where trees will be replaced, and diversity of species shall also be maintained where essential to preserving a wooded area or habitat.

Response: The replacement trees have been selected by a professional landscape architect to meet the above requirements. One of the mitigation trees is an Oregon White Oak, which replaces an oak tree being removed. The rest of the trees required to be removed are Ponderosa Pines and assorted landscape deciduous species. Mitigation tree species for those trees include Oregon Crab Apple, Vine Maples, Serviceberry, and Osoberry. Mitigation trees have been chosen from the approved tree list to provide comparable shade potential and other characteristics, and to account for height and canopy restrictions associated with BPA easement, where the trees will be planted.

(.04) All trees to be planted shall consist of nursery stock that meets requirements of the American Association of Nurserymen (AAN) American Standards for Nursery Stock (ANSI Z60.1) for top grade.

(.05) Replacement Tree Location.

A. City Review Required. The City shall review tree relocation or replacement plans in order to provide optimum enhancement, preservation and protection of wooded areas. To the extent feasible and desirable, trees shall be relocated or replaced on-site and within the same general area as trees removed.

B. Relocation or Replacement Off-Site. When it is not feasible or desirable to relocate or replace trees on-site, relocation or replacement may be made at another location approved by the City.

Response: As shown on the Preliminary Landscape Plan (Exhibit A), 29 replacement trees are proposed within Open Space Tract A, in addition to 26 street trees.

(.06) City Tree Fund. Where it is not feasible to relocate or replace trees on site or at another approved location in the City, the Tree Removal Permit grantee shall pay into the City Tree Fund, which fund is hereby created, an amount of money approximately the value as defined by this subchapter, of the replacement trees that would otherwise be required by this subchapter. The City shall use the City Tree Fund for the purpose of producing, maintaining and preserving wooded areas and heritage trees, and for planting trees within the City.

A. The City Tree Fund shall be used to offer trees at low cost on a first-come, first-serve basis to any Type A Permit grantee who requests a tree and registers with the City Tree Fund.

B. In addition, and as funds allow, the City Tree Fund shall provide educational materials to assist with tree planting, mitigation, and relocation.

Response: The Applicant will replace the trees onsite.

(.07) Exception. Tree replacement may not be required for applicants in circumstances where the Director determines that there is good cause to not so require. Good cause shall be based on a consideration of preservation of natural resources, including preservation of mature trees and diversity of ages of trees. Other criteria shall include consideration of terrain, difficulty of replacement and impact on adjacent property.

Response: The Applicant is not requesting an exception to the tree replacement requirement. Section 4.620.10. Tree Protection During Construction

Section 4.620.10 TREE PROTECTION DURING CONSTRUCTION

(.01) Where tree protection is required by a condition of development under Chapter 4 or by a Tree Maintenance and Protection Plan approved under this subchapter, the following standards apply: A. All trees required to be protected must be clearly labeled as such.

-
- B. **Placing Construction Materials Near Tree.** No person may conduct any construction activity likely to be injurious to a tree designated to remain, including, but not limited to, placing solvents, building material, construction equipment, or depositing soil, or placing irrigated landscaping, within the drip line, unless a plan for such construction activity has been approved by the Planning Director or Development Review Board based upon the recommendations of an arborist.
 - C. **Attachments to Trees During Construction.** Notwithstanding the requirement of WC 4.620.10(1)(A), no person shall attach any device or wire to any protected tree unless needed for tree protection.
 - D. **Protective Barrier.** Before development, land clearing, filling or any land alteration for which a Tree Removal Permit is required, the developer shall erect and maintain suitable barriers as identified by an arborist to protect remaining trees. Protective barriers shall remain in place until the City authorizes their removal or issues a final certificate of occupancy, whichever occurs first. Barriers shall be sufficiently substantial to withstand nearby construction activities. Plastic tape or similar forms of markers do not constitute "barriers." The most appropriate and protective barrier shall be utilized. Barriers are required for all trees designated to remain, except in the following cases:
 - 1. **Right-of-Ways and Easements.** Street right-of-way and utility easements may be cordoned by placing stakes a minimum of fifty (50) feet apart and tying ribbon, plastic tape, rope, etc., from stake to stake along the outside perimeters of areas to be cleared.
 - 2. **Any property area separate from the construction or land clearing area onto which no equipment will venture may also be cordoned off as described in paragraph (D) of this subsection, or by other reasonable means as approved by the reviewing authority.**

Response: The Preliminary Tree Preservation and Removal Plan (Exhibit A) provides direction regarding the protection of trees on the site. The applicable standards will be included on the construction documents as well.

CHAPTER 4. ANNEXATIONS AND URBAN GROWTH BOUNDARY AMENDMENTS

Section 4.700 PROCEDURES RELATING TO THE PROCESSING OF REQUESTS FOR ANNEXATION AND URBAN GROWTH BOUNDARY AMENDMENTS.

(.01) The City of Wilsonville is located within the Portland Metropolitan Area, and is therefore subject to regional government requirements affecting changes to the city limits and changes to the Urban Growth Boundary (UGB) around Wilsonville. The City has the authority to annex properties as prescribed in State law, but the City's role in determining the UGB is primarily advisory to Metro, as provided in Oregon Revised Statutes. The following procedures will be used to aid the City Council in formulating recommendations to those regional entities. [Amended by Ordinance No. 538, 2/21/02.]

- A. Proponents of such changes shall provide the Planning Director with all necessary maps and written information to allow for review by city decision-makers. The Planning Director, after consultation with the City Attorney, will determine whether each given request is quasi-judicial or legislative in nature and will make the necessary arrangements for review based upon that determination.

Response: The Applicant has provided the required information. The Planning Director has determined that the annexation request is subject to quasi-judicial review.

-
- B. Written information submitted with each request shall include an analysis of the relationship between the proposal and the City's Comprehensive Plan, applicable statutes, as well as the Statewide Planning Goals and any officially adopted regional plan that may be applicable.

Response: Please refer to the responses addressing compliance with the relevant Comprehensive Plan goals.

IV. Conclusion

The required findings have been made and this written narrative and accompanying documentation demonstrate that the application is consistent with the applicable standards of the City of Wilsonville. The evidence in the record is substantial and supports approval of the application. Therefore, the Applicant respectfully requests that the City approve this Combined Application.

Exhibit A: Preliminary Plans

FROG POND CROSSING

PLANNED UNIT DEVELOPMENT PRELIMINARY PLANS

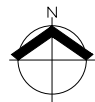
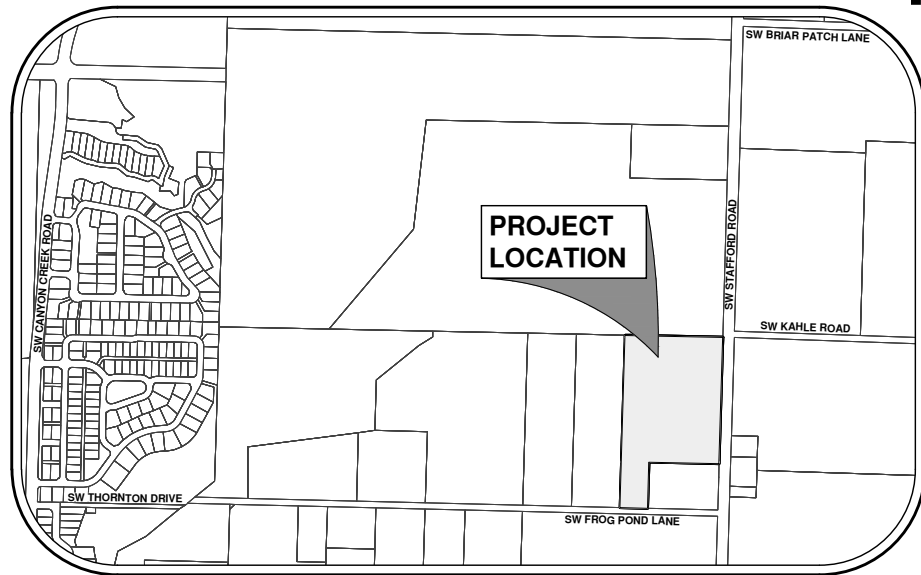

VICINITY MAP

1" = 500'

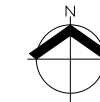
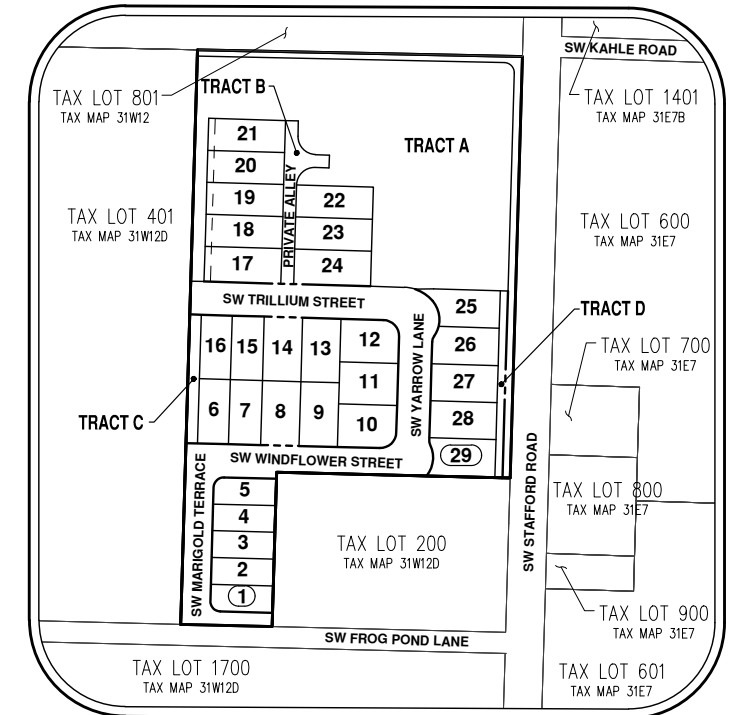

SITE MAP

1" = 150'

APPLICANT:

VENTURE PROPERTIES, INC.
4230 GALEWOOD STREET #100
LAKE OSWEGO, OR 97035

**PLANNING / ENGINEERING /
SURVEYING TEAM:**

AKS ENGINEERING & FORESTRY, LLC
CONTACT: AMY DOWNHOUR / MIMI DOUKAS
12965 SW HERMAN RD, SUITE 100
TUALATIN, OR 97062
PH: 503-563-6151

PROJECT LOCATION:

SOUTHWEST OF THE INTERSECTION OF SW KAHLE ROAD
AND SW STAFFORD ROAD, WILSONVILLE, OREGON

PROPERTY DESCRIPTION:

TAX LOT(S) 100, 300, AND 302, CLACKAMAS COUNTY
ASSESSOR'S MAP 3S 1W 12. TOWNSHIP 3 SOUTH, RANGE
1 WEST, LOCATED IN SECTION 12, WILLAMETTE MERIDIAN,
CITY OF WILSONVILLE, CLACKAMAS COUNTY, OREGON.

EXISTING LAND USE:

EXISTING HOUSE WITH ACCESSORY STRUCTURES.

PROJECT PURPOSE:

PLANNED UNIT DEVELOPMENT FOR FUTURE SINGLE-FAMILY HOMES.

VERTICAL DATUM:

VERTICAL DATUM: DERIVED FROM GPS OBSERVATIONS
USING THE TRIMBLE VRS NOW NETWORK (NAVD 88).

HORIZONTAL DATUM:

HORIZONTAL DATUM: A LOCAL DATUM PLANE SCALED
FROM OREGON STATE PLANE NORTH 3601 NAD83(2011)
EPOCH 2010.0000 BY HOLDING A PROJECT MEAN GROUND
COMBINED SCALE FACTOR OF 1.0001095227 AT A
CALCULATED CENTRAL PROJECT POINT WITH GRID VALUES
OF (NORTH:611619.612 EAST:7624210.554). THE MERIDIAN
CONVERGENCE ANGLE AT THE CALCULATED CENTRAL
POINT IS -1'35"37". THE STATE PLANE COORDINATES
WERE DERIVED FROM THE TRIMBLE VRS NETWORK.

SITE INFO:

GROSS AREA: 8.46 AC.
TL 100 AREA: 2.02 AC. - 27227 SW STAFFORD RD
TL 300 AREA: 6.42 AC. - NO SITUS
TL 302 AREA: 0.02 AC. - NO SITUS

SHEET INDEX

- P-01 COVER SHEET WITH LEGEND, VICINITY, AND SITE MAPS
- P-02 ZONING MAP
- P-03 ANNEXATION PLAN
- P-04 PRELIMINARY EXISTING CONDITIONS PLAN
- P-05 PRELIMINARY AERIAL PHOTOGRAPH PLAN
- P-06 PRELIMINARY DIMENSIONED P.U.D. PLAN
- P-07 PRELIMINARY GRADING AND EROSION CONTROL PLAN
- P-08 PRELIMINARY COMPOSITE UTILITY PLAN
- P-09 PRELIMINARY STREET PLAN
- P-10 PRELIMINARY STREET CROSS SECTIONS
- P-11 PRELIMINARY STREET PROFILES
- P-12 PRELIMINARY TREE PRESERVATION AND REMOVAL PLAN
- P-13 PRELIMINARY TREE PRESERVATION AND REMOVAL TABLE
- P-14 PRELIMINARY DEMOLITION PLAN
- P-15 PRELIMINARY STREET TREE PLANTING PLAN
- P-16 PRELIMINARY TRACT C AND D PLANTING PLANS
- P-17 PRELIMINARY FRONTAGE WALL DETAILS
- P-18 PRELIMINARY STORMWATER DETAILS

LEGEND

	EXISTING	PROPOSED		EXISTING	PROPOSED
DECIDUOUS TREE			STORM DRAIN CLEAN OUT		
CONIFEROUS TREE			STORM DRAIN CATCH BASIN		
FIRE HYDRANT			STORM DRAIN AREA DRAIN		
WATER BLOWOFF			STORM DRAIN MANHOLE		
WATER METER			GAS METER		
WATER VALVE			GAS VALVE		
DOUBLE CHECK VALVE			GUY WIRE ANCHOR		
AIR RELEASE VALVE			UTILITY POLE		
SANITARY SEWER CLEAN OUT			POWER VAULT		
SANITARY SEWER MANHOLE			POWER JUNCTION BOX		
SIGN			POWER PEDESTAL		
STREET LIGHT			COMMUNICATIONS VAULT		
MAILBOX			COMMUNICATIONS JUNCTION BOX		
			COMMUNICATIONS RISER		
	EXISTING	PROPOSED			
RIGHT-OF-WAY LINE					
BOUNDARY LINE					
PROPERTY LINE					
CENTERLINE					
DITCH					
CURB					
EDGE OF PAVEMENT					
EASEMENT					
FENCE LINE					
GRAVEL EDGE					
POWER LINE					
OVERHEAD WIRE					
COMMUNICATIONS LINE					
FIBER OPTIC LINE					
GAS LINE					
STORM DRAIN LINE					
SANITARY SEWER LINE					
WATER LINE					



RENEWALS:	DECEMBER 31, 2021
JOB NUMBER:	5252
DATE:	08/26/2021
DESIGNED BY:	AJD
DRAWN BY:	NLB
CHECKED BY:	MD

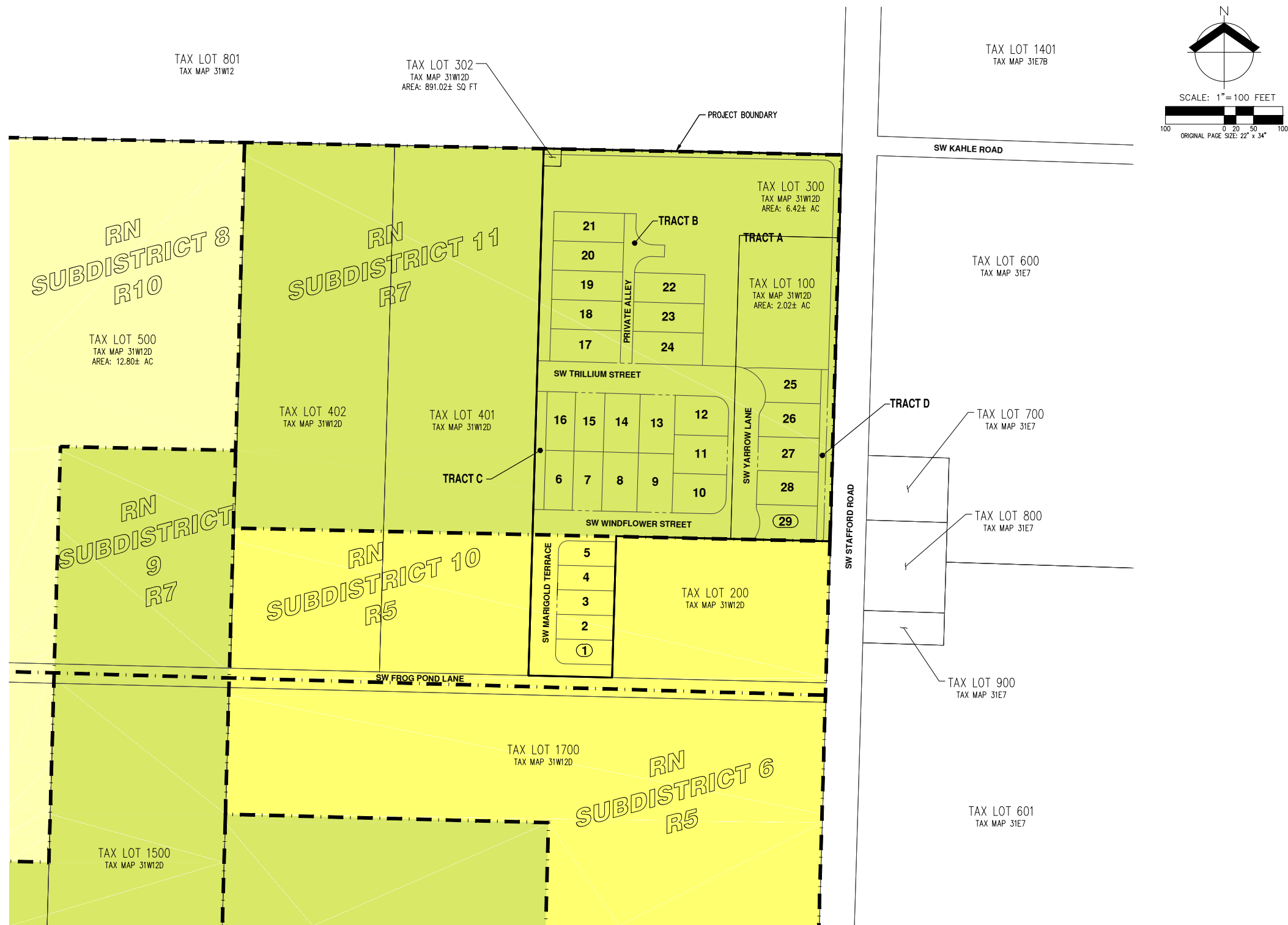

LEGEND

R5 ZONE	
R7 ZONE	
R10 ZONE	

ZONING MAP
FROG POND CROSSING
VENTURE PROPERTIES, INC.
WILSONVILLE, OREGON

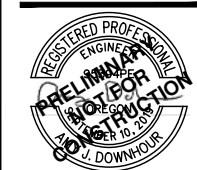

RENEWAL: DECEMBER 31, 2021

JOB NUMBER:	5252
DATE:	08/26/2021
DESIGNED BY:	AJD
DRAWN BY:	NLB
CHECKED BY:	MD

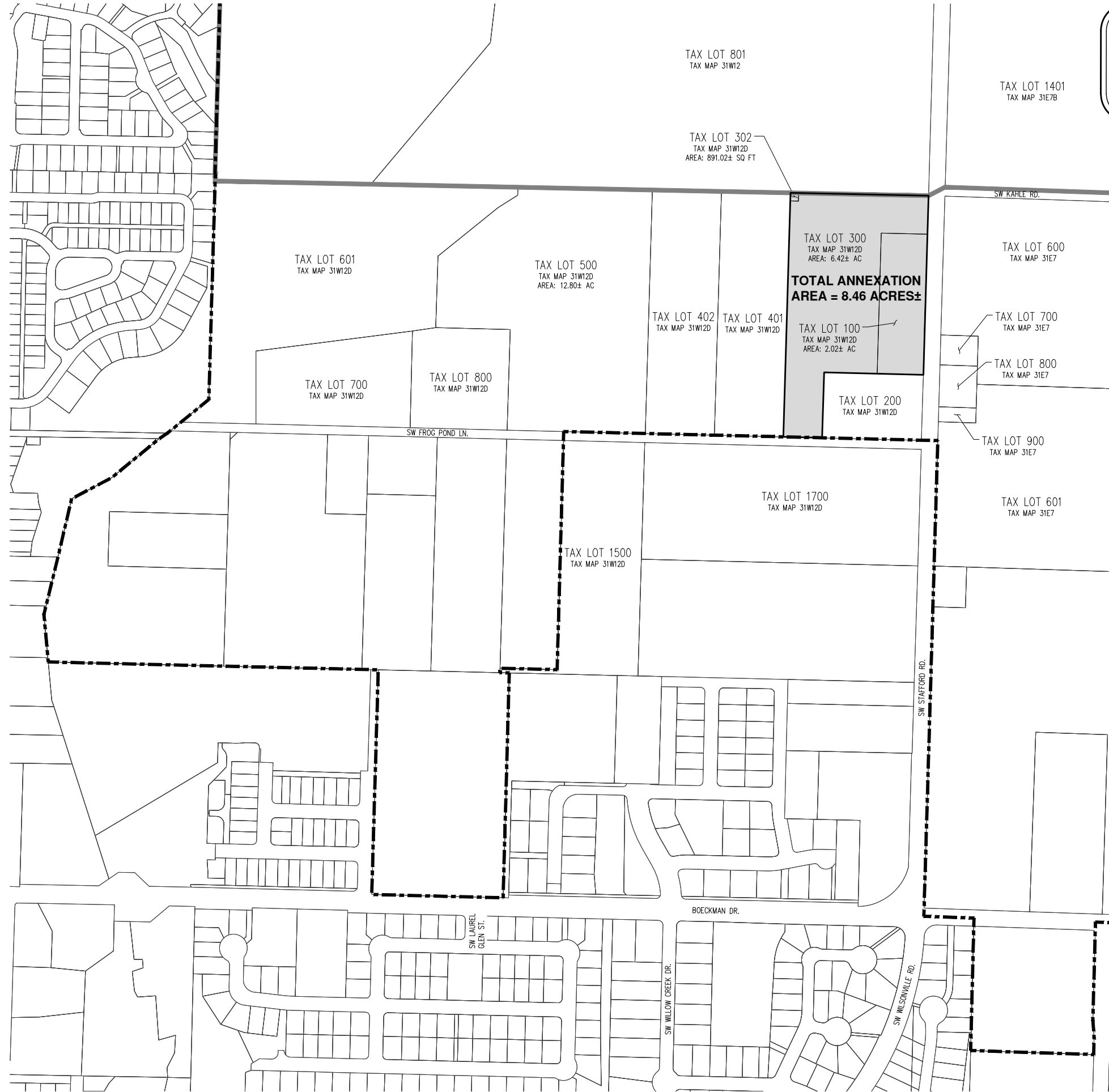

LEGEND

PROPOSED AREA TO BE ANNEXED

URBAN GROWTH BOUNDARY

CITY LIMITS

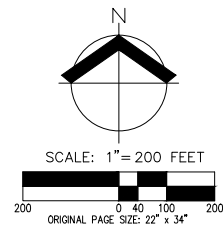

**ANNEXATION PLAN
 FROG POND CROSSING
 VENTURE PROPERTIES, INC.
 WILSONVILLE, OREGON**



RENEWS: DECEMBER 31, 2021

JOB NUMBER:	5252
DATE:	08/26/2021
DESIGNED BY:	AJD
DRAWN BY:	NLB
CHECKED BY:	MD

TREE TABLE		
TREE NUMBER	TYPE	DBH (IN.)
10386	DECIDUOUS	6
10393	DECIDUOUS	10
10407	DECIDUOUS	6
10766	DECIDUOUS	6
10770	CONIFEROUS	47
10771	CONIFEROUS	23
10772	DECIDUOUS	10
10773	DECIDUOUS	7,8,8,8
10776	DECIDUOUS	6,6
10778	CONIFEROUS	21
10863	DECIDUOUS	6,10,12,12,13,13,13,14,15
10872	DECIDUOUS	40
10932	DECIDUOUS	14
11306	CONIFEROUS	38
20110	DECIDUOUS	10,10,14,28
20117	DECIDUOUS	40

TREE TABLE		
TREE NUMBER	TYPE	DBH (IN.)
20118	DECIDUOUS	28
20119	DECIDUOUS	25
20122	DECIDUOUS	31
20124	DECIDUOUS	42
20125	DECIDUOUS	42
20128	DECIDUOUS	63
20131	DECIDUOUS	37
20220	DECIDUOUS	7,9,10
20222	DECIDUOUS	6
20253	CONIFEROUS	10
20254	CONIFEROUS	7
20255	CONIFEROUS	17
20314	DECIDUOUS	6
20315	DECIDUOUS	8,10
20342	DECIDUOUS	8,8,9,10
20344	DECIDUOUS	6,6

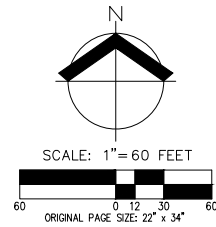

TREE TABLE		
TREE NUMBER	TYPE	DBH (IN.)
20350	DECIDUOUS	8,6,6
20353	DECIDUOUS	32
20355	CONIFEROUS	43
20414	DECIDUOUS	15
20525	VOID	27
20528	DECIDUOUS	50
50044	DECIDUOUS	9,10
50048	DECIDUOUS	16
50049	CONIFEROUS	29
50050	CONIFEROUS	27
50051	CONIFEROUS	22
50052	CONIFEROUS	15
50053	CONIFEROUS	23
50054	CONIFEROUS	11
50055	CONIFEROUS	20
50056	CONIFEROUS	20

TREE TABLE		
TREE NUMBER	TYPE	DBH (IN.)
50057	CONIFEROUS	13
50058	CONIFEROUS	13
50059	CONIFEROUS	17
50060	CONIFEROUS	13
50061	CONIFEROUS	9
50062	CONIFEROUS	9
50064	CONIFEROUS	14
50067	CONIFEROUS	43
50068	CONIFEROUS	12
50069	CONIFEROUS	15
50070	CONIFEROUS	11
50071	CONIFEROUS	14
50072	CONIFEROUS	18
50073	VOID	24
50074	CONIFEROUS	24
58865	DECIDUOUS	8

NOTES:

- UTILITIES SHOWN ARE BASED ON UNDERGROUND UTILITY LOCATE MARKINGS AS PROVIDED BY OTHERS, PROVIDED PER UTILITY LOCATE TICKET NUMBERS 21084848, 21084859, 21084868, 21084871, 21084875. THE SURVEYOR MAKES NO GUARANTEE THAT THE UNDERGROUND LOCATES REPRESENT THE ONLY UTILITIES IN THE AREA. CONTRACTORS ARE RESPONSIBLE FOR VERIFYING ALL EXISTING CONDITIONS PRIOR TO BEGINNING CONSTRUCTION.
- FIELD WORK WAS CONDUCTED FEBRUARY 17-25, AND JUNE 10, 2021.
- VERTICAL DATUM: DERIVED FROM GPS OBSERVATIONS USING THE TRIMBLE VRS NOW NETWORK (NAVD 88).
- HORIZONTAL DATUM: A LOCAL DATUM PLANE SCALED FROM OREGON STATE PLANE NORTH 3601 NAD83(2011) EPOCH 2010.0000 BY HOLDING A PROJECT MEAN GROUND COMBINED SCALE FACTOR OF 1.0001095227 AT A CALCULATED CENTRAL PROJECT POINT WITH GRID VALUES OF (NORTH:611619.612 EAST:7624210.554). THE MERIDIAN CONVERGENCE ANGLE AT THE CALCULATED CENTRAL POINT IS -1'35"37". THE STATE PLANE COORDINATES WERE DERIVED FROM THE TRIMBLE VRS NETWORK.
- THIS IS NOT A PROPERTY BOUNDARY SURVEY TO BE RECORDED WITH THE COUNTY SURVEYOR. BOUNDARIES MAY BE PRELIMINARY AND SHOULD BE CONFIRMED WITH THE STAMPING SURVEYOR PRIOR TO RELYING ON FOR DETAILED DESIGN OR CONSTRUCTION.
- BUILDING FOOTPRINTS ARE MEASURED TO SIDING UNLESS NOTED OTHERWISE. CONTACT SURVEYOR WITH QUESTIONS REGARDING BUILDING TIES.
- CONTOUR INTERVAL IS 1 FOOT.
- TREES WITH DIAMETER OF 6" AND GREATER ARE SHOWN. TREE DIAMETERS WERE MEASURED UTILIZING A DIAMETER TAPE AT BREAST HEIGHT. TREE INFORMATION IS SUBJECT TO CHANGE UPON ARBORIST INSPECTION.
- WETLAND & WATER BOUNDARIES SHOWN WERE DELINEATED BY AKS ENGINEERING & FORESTRY, LLC. ON FEBRUARY 24, 2021 AND WERE PROFESSIONALLY SURVEYED BY AKS ON 02-25-2021.

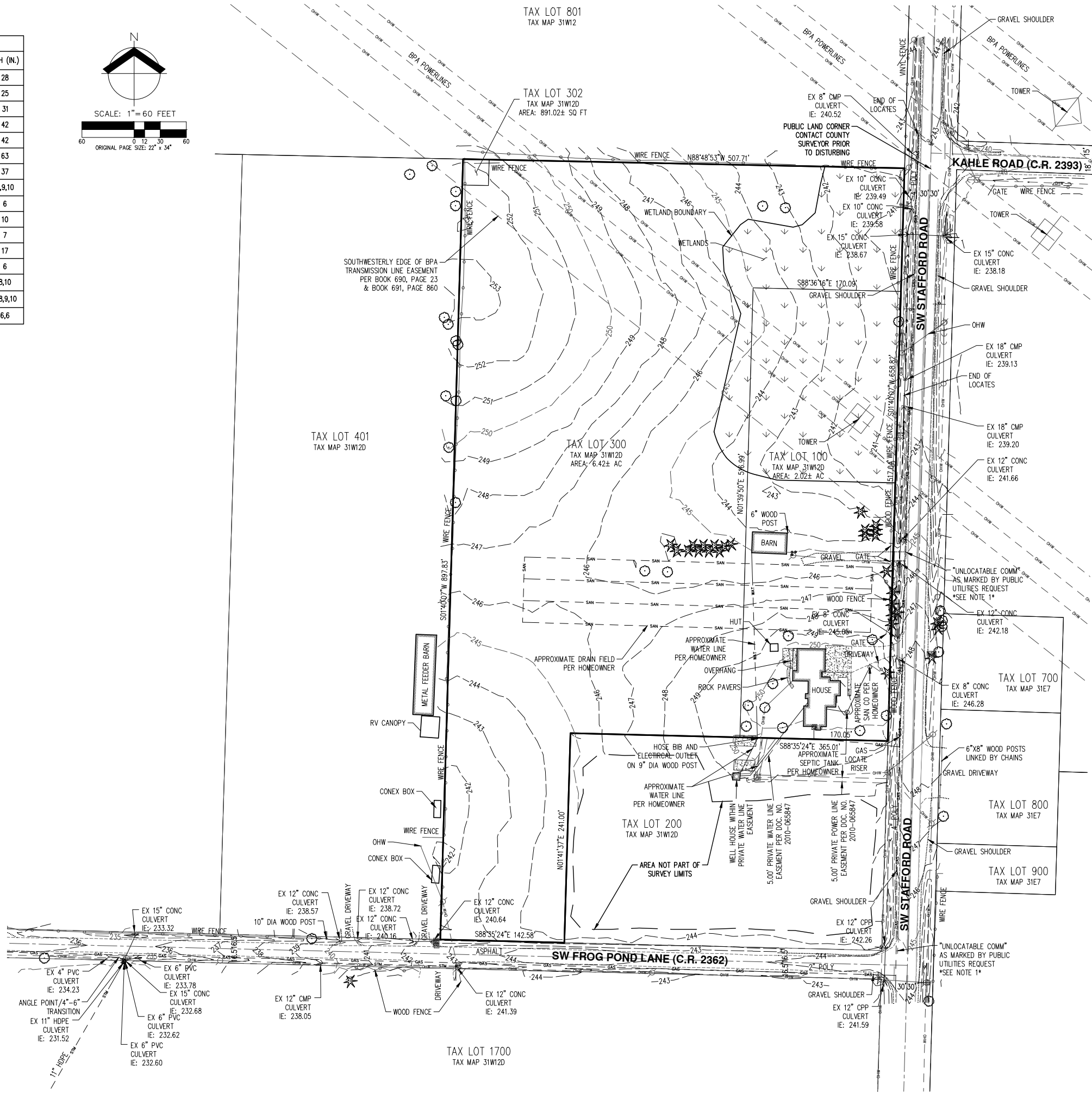

PRELIMINARY EXISTING CONDITIONS PLAN
FROG POND CROSSING
VENTURE PROPERTIES, INC.
WILSONVILLE, OREGON

AKS
 AKS ENGINEERING & FORESTRY, LLC
 12965 SW HERMAN RD, STE 100
 TUALATIN, OR 97062
 503.563.6151
 WWW.AKS-ENG.COM
 ENGINEERING • SURVEYING • LANDSCAPE ARCHITECTURE
 FORESTRY • PLANNING • LANDSCAPE ARCHITECTURE

REGISTERED PROFESSIONAL LAND SURVEYOR
 PRELIMINARY NOT FOR CONSTRUCTION
 JANUARY 17, 2005
 ROBERT D. RETTIG
 60124LS
 RENEWS: 12/31/22

JOB NUMBER:	5252
DATE:	08/26/2021
DESIGNED BY:	AJD
DRAWN BY:	NLB
CHECKED BY:	MD

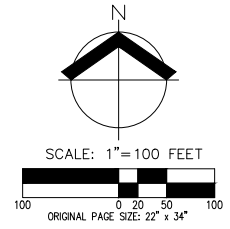

PRELIMINARY AERIAL PHOTOGRAPH PLAN

FROG POND CROSSING
VENTURE PROPERTIES, INC.
WILSONVILLE, OREGON

AKS
 AKS ENGINEERING & FORESTRY, LLC
 12965 SW HERMAN RD., STE 100
 TUALATIN, OR 97062
 503.563.6151
 WWW.AKS-ENG.COM

ENGINEERING • SURVEYING • NATURAL RESOURCES
 FORESTRY • PLANNING • LANDSCAPE ARCHITECTURE



RENEWS: DECEMBER 31, 2021

JOB NUMBER: 5252
 DATE: 08/26/2021
 DESIGNED BY: AJD
 DRAWN BY: NLB
 CHECKED BY: MD

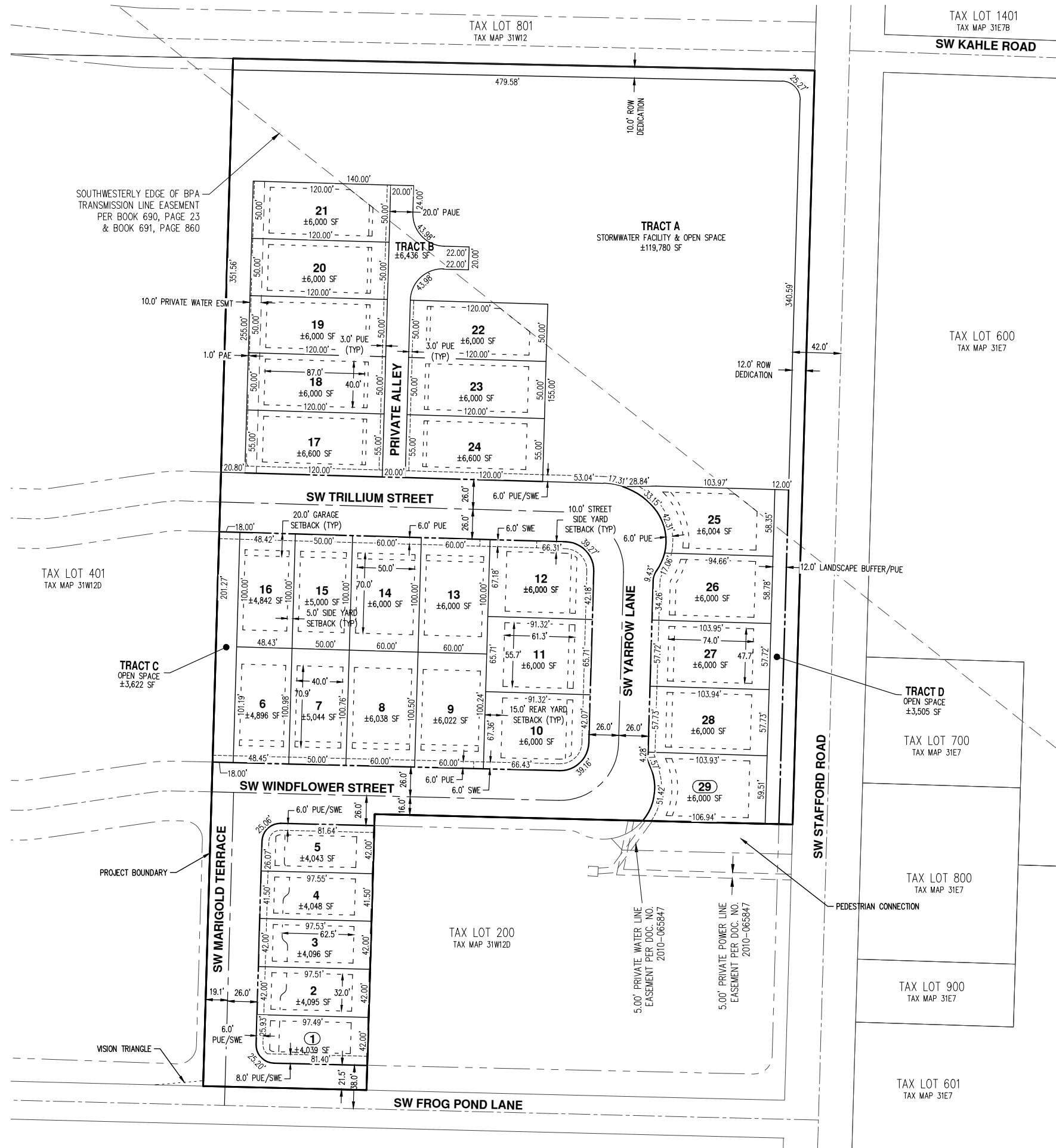

- NOTES:
- TRACT A IS FOR STORMWATER TREATMENT, PEDESTRIAN ACCESS, AND LANDSCAPE PURPOSES. IT IS SUBJECT TO STORM DRAINAGE TO BENEFIT THE CITY OF WILSONVILLE OVER ITS ENTIRETY.
 - TRACT B IS A PRIVATE ROADWAY TRACT AND IS SUBJECT TO A PUBLIC ACCESS EASEMENT AND PEDESTRIAN ACCESS EASEMENT. THE TRACT IS ALSO SUBJECT TO A JOINT UTILITY EASEMENT BENEFITING THE CITY OF WILSONVILLE OVER ITS ENTIRETY.
 - TRACT C IS FOR PEDESTRIAN PURPOSES AND IS SUBJECT TO A PUBLIC ACCESS EASEMENT AND PEDESTRIAN ACCESS EASEMENT.
 - TRACT D IS FOR LANDSCAPE BUFFER PURPOSES.

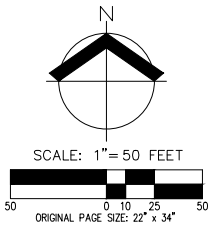

LOT SIZE SUMMARY

	* SUBDISTRICT 11 R-5	* SUBDISTRICT 10 R-7
MIN. LOT SIZE	4,039 SF	4,842 SF
AVG. LOT SIZE	4,064 SF	5,877 SF

SUMMARY OF LAND USES

LAND USE	SF	PERCENTAGE OF PROPERTY
1. GROSS AREA IN PLAT	368,350	—
2. LANDSCAPE COVERAGE AREA/OPEN SPACE	126,125	34%
3. ROW	79,955	22%
4. LOT AREA	155,380	42%
5. STORMWATER	6,888	2%

SETBACKS

	R-7	R-5
FRONT	15 FT	12 FT
REAR	15 FT	15 FT
SIDE - INTERNAL	5 FT	5 FT
SIDE - CORNER	10 FT	10 FT
GARAGE - FROM ALLEY	18 FT	18 FT
GARAGE - FROM STREET	20 FT	20 FT

* SEE SHEET P-05 FOR ZONING MAP

EASEMENT LEGEND

PUE	PUBLIC UTILITY EASEMENT
PAUE	PUBLIC ACCESS AND UTILITY EASEMENT
SWE	SIDEWALK EASEMENT
PAE	PUBLIC ACCESS EASEMENT

PRELIMINARY DIMENSIONED P.U.D. PLAN
FROG POND CROSSING
VENTURE PROPERTIES, INC.
WILSONVILLE, OREGON



RENEW: DECEMBER 31, 2021

JOB NUMBER: 5252
 DATE: 08/26/2021
 DESIGNED BY: AJD
 DRAWN BY: NLB
 CHECKED BY: MD

**PRELIMINARY GRADING AND EROSION CONTROL PLAN
 FROG POND CROSSING
 VENTURE PROPERTIES, INC.
 WILSONVILLE, OREGON**

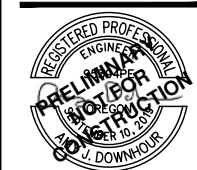

RENEWALS: DECEMBER 31, 2021
 JOB NUMBER: 5252
 DATE: 08/26/2021
 DESIGNED BY: A.J.D.
 DRAWN BY: N.L.B.
 CHECKED BY: M.D.

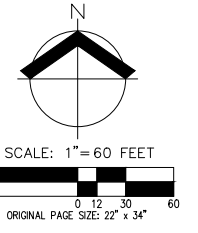
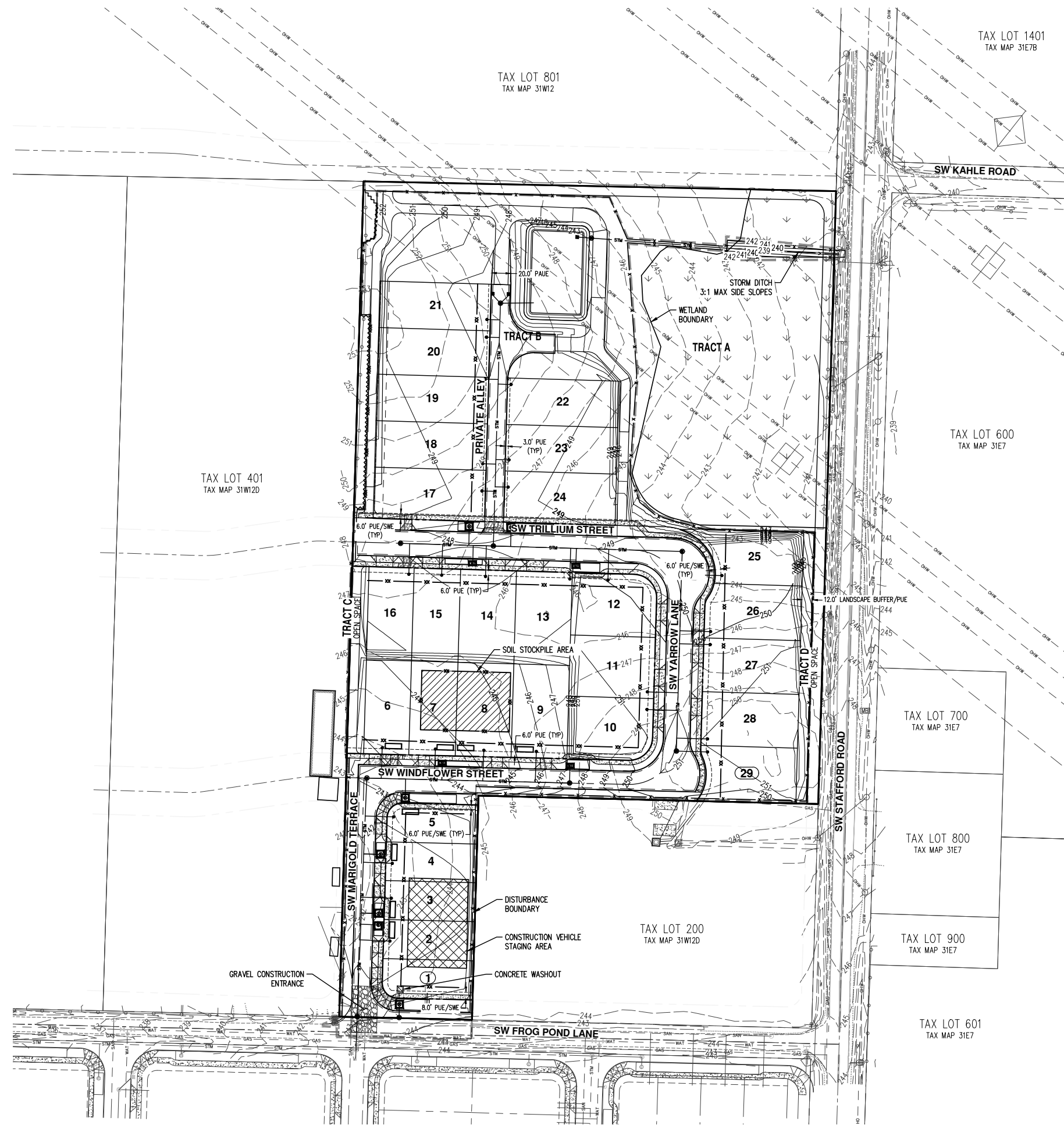

EASEMENT LEGEND	
PUE	PUBLIC UTILITY EASEMENT
PAUE	PUBLIC ACCESS AND UTILITY EASEMENT
SWE	SIDEWALK EASEMENT

LEGEND	
EXISTING GROUND CONTOUR (1 FT)	---
EXISTING GROUND CONTOUR (5 FT)	---
FINISHED GRADE CONTOUR (1 FT)	---
FINISHED GRADE CONTOUR (5 FT)	---
SEDIMENT FENCE (TO BE INSTALLED PRIOR TO GRADING)	x
SEDIMENT FENCE (TO BE INSTALLED AFTER GRADING)	xx
CONCRETE WASHOUT AREA	□
AREA DRAIN PROTECTION (TYP)	▣
GRAVEL CONSTRUCTION ENTRANCE	▨
EXISTING WETLAND	▽
TREE PROTECTION/CONSTRUCTION FENCE (TREE PROTECTION AREA)	~
GRADING LIMITS	- - - -

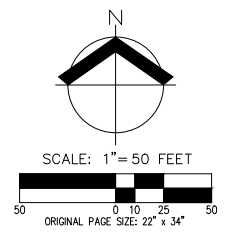
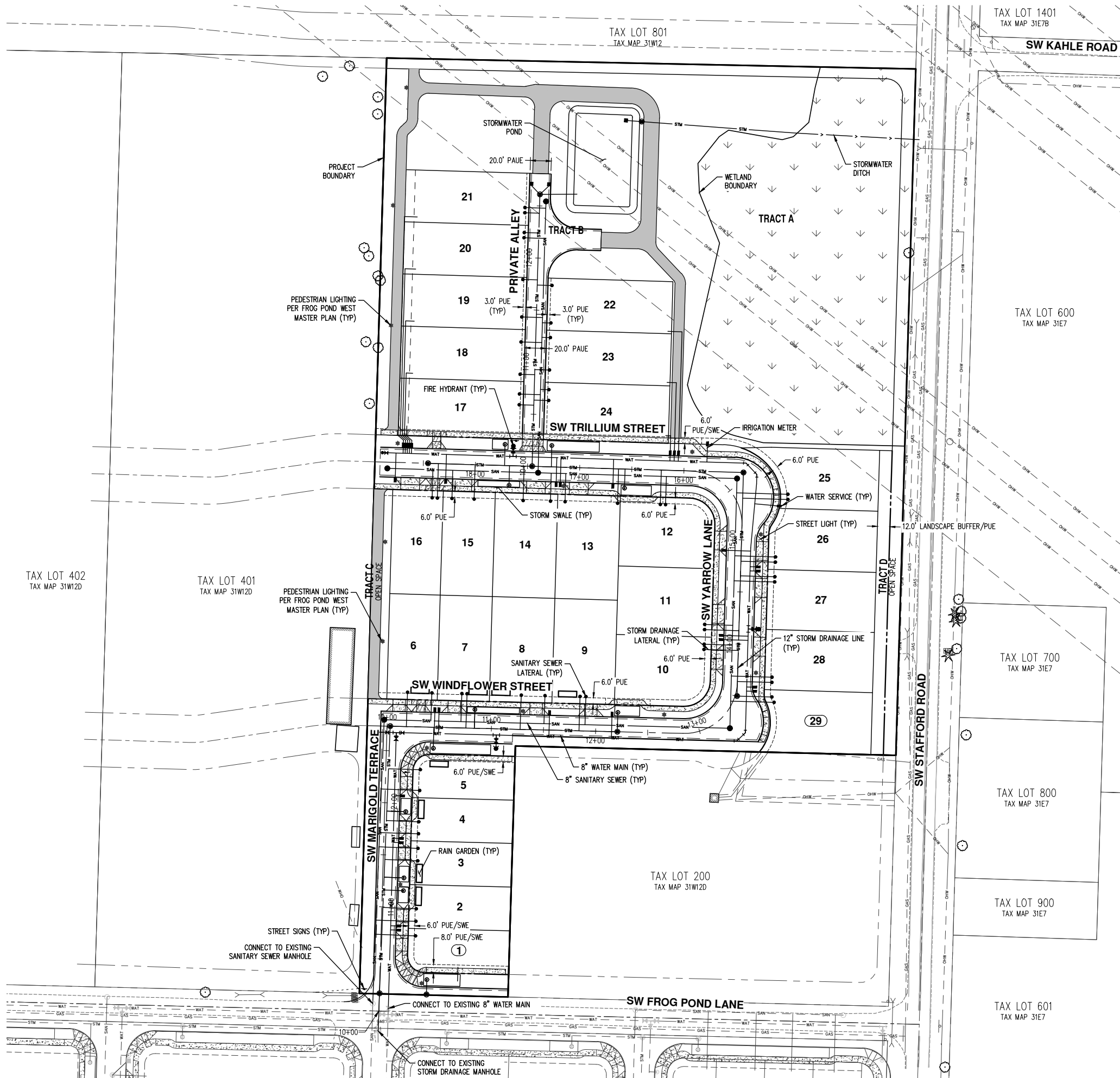

PRELIMINARY COMPOSITE UTILITY PLAN
FROG POND CROSSING
VENTURE PROPERTIES, INC.
WILSONVILLE, OREGON

AKS
 AKS ENGINEERING & FORESTRY, LLC
 12965 SW HERMAN RD., STE. 100
 TUALATIN, OR 97062
 503.563.6151
 WWW.AKS-ENG.COM
 ENGINEERING • SURVEYING • NATURAL RESOURCES
 FORESTRY • PLANNING • LANDSCAPE ARCHITECTURE



RENEWS: DECEMBER 31, 2021
 JOB NUMBER: 5252
 DATE: 08/26/2021
 DESIGNED BY: AJD
 DRAWN BY: NLB
 CHECKED BY: MD

EASEMENT LEGEND	
PUE	PUBLIC UTILITY EASEMENT
PAUE	PUBLIC ACCESS AND UTILITY EASEMENT
SWE	SIDEWALK EASEMENT

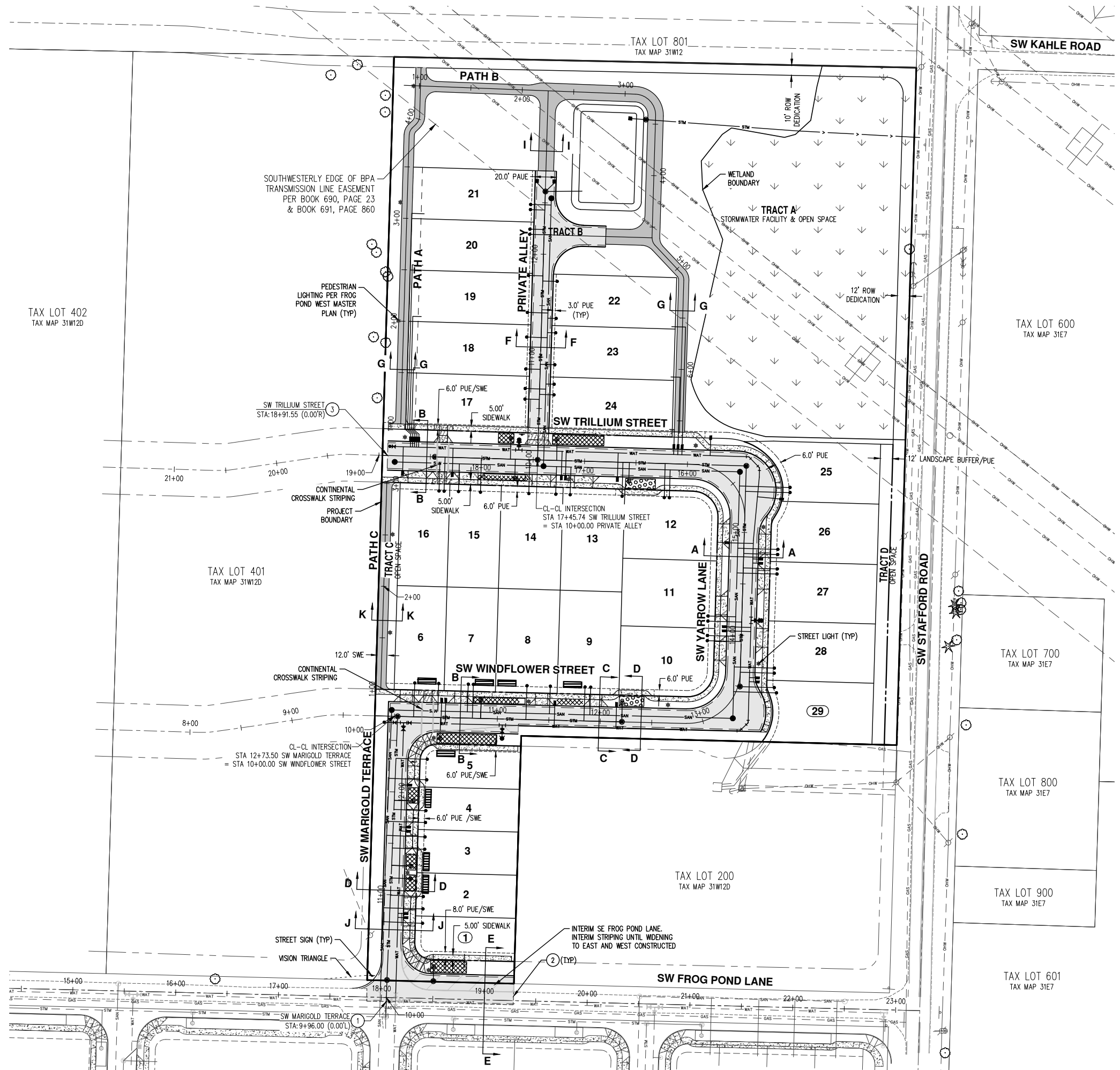
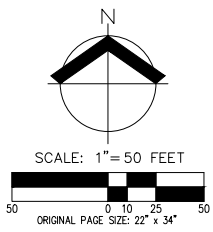

- # KEYED NOTES**
- BEGIN STREET IMPROVEMENTS.
 - SAWCUT EXISTING ASPHALT ROAD.
 - END STREET IMPROVEMENTS.

- LEGEND**
- SIDEWALK AND DRIVEWAY APPROACHES TO BE INSTALLED BY HOMEBUILDER.
 - SIDEWALK AND DRIVEWAY APPROACHES TO BE INSTALLED BY CONTRACTOR.
 - STORMWATER SWALE TO BE CONSTRUCTED BY CONTRACTOR
 - STORMWATER PLANTER TO BE CONSTRUCTED BY CONTRACTOR
 - STORMWATER RAIN GARDEN TO BE CONSTRUCTED BY HOMEBUILDER.
 - TRAIL TO BE CONSTRUCTED BY CONTRACTOR.
 - ASPHALT CONCRETE PAVEMENT
 - EXISTING WETLAND

- EASEMENT LEGEND**
- PUE PUBLIC UTILITY EASEMENT
 - PAUE PUBLIC ACCESS AND UTILITY EASEMENT
 - SWE SIDEWALK EASEMENT

**PRELIMINARY STREET PLAN
 FROG POND CROSSING
 VENTURE PROPERTIES, INC.
 WILSONVILLE, OREGON**



RENEW: DECEMBER 31, 2021
 JOB NUMBER: 5252
 DATE: 08/26/2021
 DESIGNED BY: AJD
 DRAWN BY: NLB
 CHECKED BY: MD

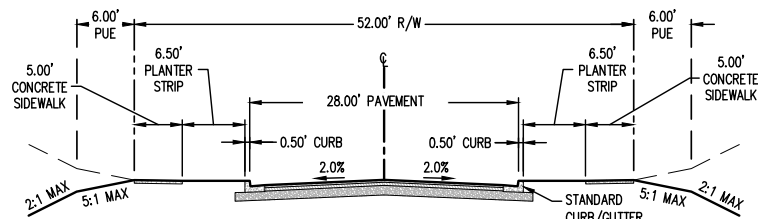

A TYPICAL LOCAL STREET CROSS SECTION
 CROSS SECTION A SHALL BE USED IN THE FOLLOWING LOCATIONS:
 SW YARROW LANE: STA 13+51.46 TO 15+13.66
 SCALE: 1" = 10'

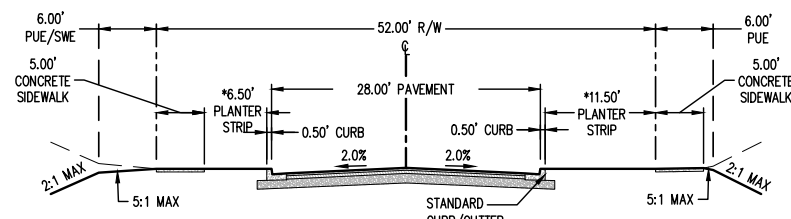

B TYPICAL LOCAL STREET CROSS SECTION WITH WIDE PLANTER STRIP
 CROSS SECTION B SHALL BE USED IN THE FOLLOWING LOCATIONS:
 SW TRILLIUM STREET: STA 15+93.83 TO 16+30.66
 SW WINDFLOWER STREET: STA 16+59.66 TO 18+91.55
 STA 10+90.91 TO 11+20.50
 SCALE: 1" = 10'

*REFER TO SECTIONS 1 AND 4 FOR VEGETATED SWALE LOCATIONS WITHIN PLANTER STRIP.

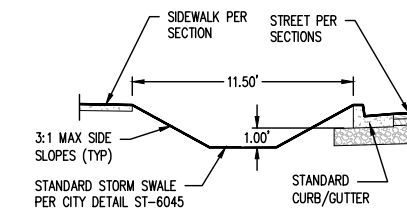

1 TYPICAL VEGETATED SWALE SECTION
 CROSS SECTION 1 SHALL BE USED IN THE PLANTER STRIP AT THE FOLLOWING LOCATION:
 SW TRILLIUM STREET: STA 16+81.74 TO 17+31.74 (NORTH)
 STA 17+69.31 TO 17+84.31 (NORTH)
 STA 16+30.66 TO 16+59.66 (SOUTH)
 SW WINDFLOWER STREET: STA 10+40.91 TO 10+99.44 (SOUTH)
 SCALE: 1" = 5'

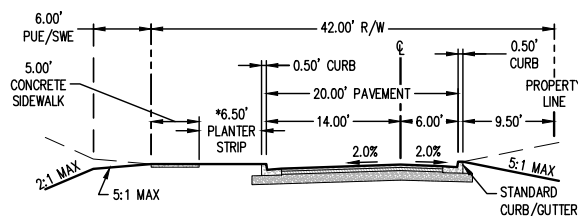

C LOCAL 3/4 STREET CROSS SECTION
 CROSS SECTION D SHALL BE USED IN THE FOLLOWING LOCATIONS:
 SW WINDFLOWER STREET: STA 11+20.50 TO STA 12+17.91
 STA 12+41.91 TO 12+95.16
 SCALE: 1" = 10'

*REFER TO SECTION 4 FOR VEGETATED SWALE LOCATIONS WITHIN PLANTER STRIP.

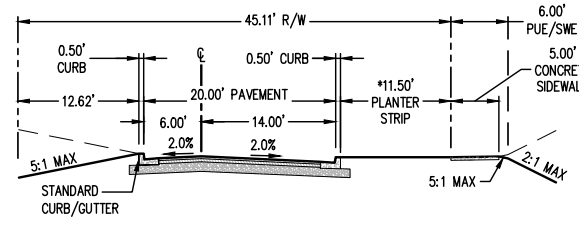

D LOCAL 3/4 STREET CROSS SECTION
 CROSS SECTION G SHALL BE USED IN THE FOLLOWING LOCATIONS:
 SW MARI GOLD TERRACE: STA 10+94.90 TO 11+49.14
 SW WINDFLOWER STREET: STA 11+80.33 TO 12+13.90
 STA 12+17.91 TO 12+41.91
 SCALE: 1" = 10'

*REFER TO SECTION 1 FOR VEGETATED SWALE LOCATIONS WITHIN PLANTER STRIP.

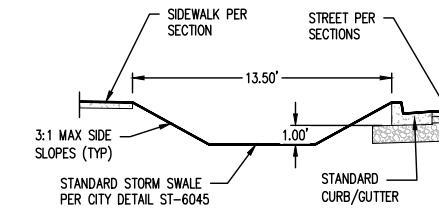

3 COLLECTOR VEGETATED SWALE SECTION
 CROSS SECTION 3 SHALL BE USED IN THE PLANTER STRIP AT THE FOLLOWING LOCATION:
 SW FROG POND LANE: STA 18+47.08 TO 18+82.08 (NORTH)
 SCALE: 1" = 5'

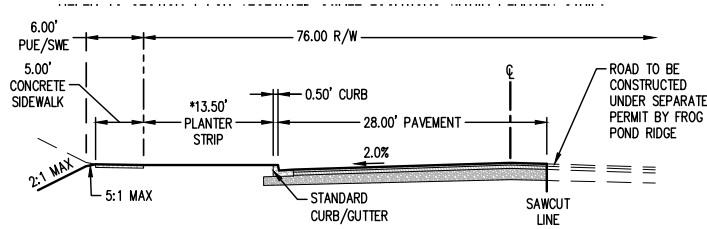

E COLLECTOR 3/4 STREET INTERIM CROSS SECTION
 CROSS SECTION H SHALL BE USED IN THE FOLLOWING LOCATIONS:
 SW FROG POND LANE: STA 18+46.60 TO 19+28.30
 SCALE: 1" = 10'

*REFER TO SECTION 3 FOR VEGETATED SWALE LOCATION WITHIN PLANTER STRIP.

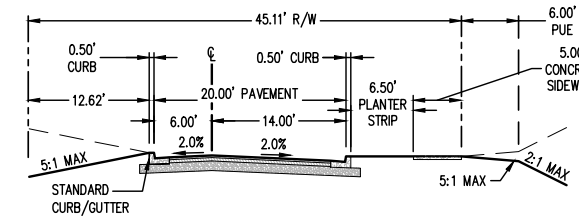

J LOCAL 3/4 STREET CROSS SECTION
 CROSS SECTION G SHALL BE USED IN THE FOLLOWING LOCATIONS:
 SW MARI GOLD TERRACE: STA 10+52.19 TO 10+94.90
 STA 11+49.14 TO 11+80.33
 STA 12+13.90 TO 12+31.69
 SCALE: 1" = 10'

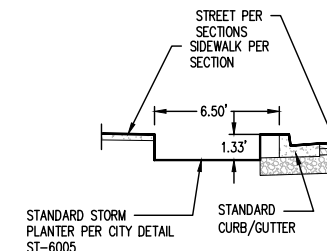

4 TYPICAL PLANTER SECTION
 CROSS SECTION 4 SHALL BE USED IN THE PLANTER STRIP AT THE FOLLOWING LOCATION:
 SW TRILLIUM STREET: STA 17+54.46 TO 18+03.49 (SOUTH)
 SW WINDFLOWER STREET: STA 10+76.42 TO 11+20.75 (NORTH)
 STA 11+57.47 TO 11+82.47 (NORTH)
 SCALE: 1" = 5'

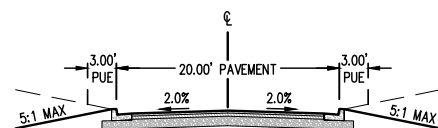

F PRIVATE ALLEY CROSS SECTION
 SCALE: 1" = 10'

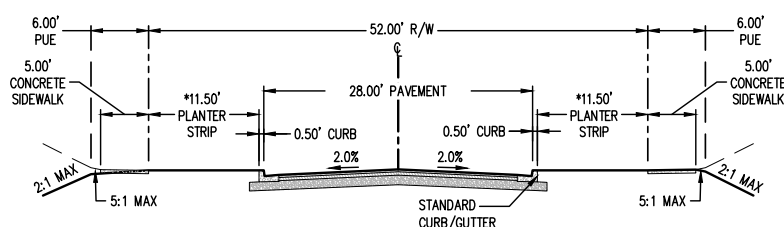

H TYPICAL LOCAL STREET CROSS SECTION WITH WIDE PLANTER STRIP
 CROSS SECTION B SHALL BE USED IN THE FOLLOWING LOCATIONS:
 SW TRILLIUM STREET: STA 16+30.66 TO 16+59.66
 SCALE: 1" = 10'

*REFER TO SECTIONS 1 FOR VEGETATED SWALE LOCATIONS WITHIN PLANTER STRIP.

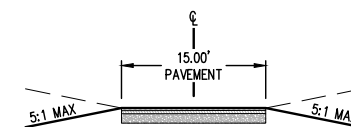

I TYPICAL PATHWAY
 SCALE: 1" = 10'

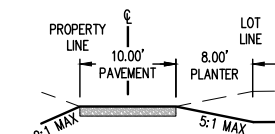

K TYPICAL PATHWAY
 SCALE: 1" = 10'

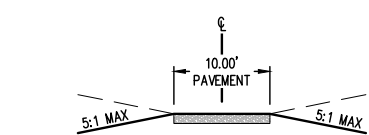

G TYPICAL PATHWAY
 SCALE: 1" = 10'

EASEMENT LEGEND

PUE	PUBLIC UTILITY EASEMENT
PAUE	PUBLIC ACCESS AND UTILITY EASEMENT
SWE	SIDEWALK EASEMENT

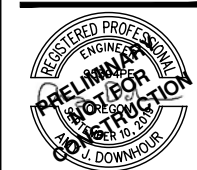

RENEWED:	DECEMBER 31, 2021
JOB NUMBER:	5252
DATE:	08/26/2021
DESIGNED BY:	AJD
DRAWN BY:	NLB
CHECKED BY:	MD

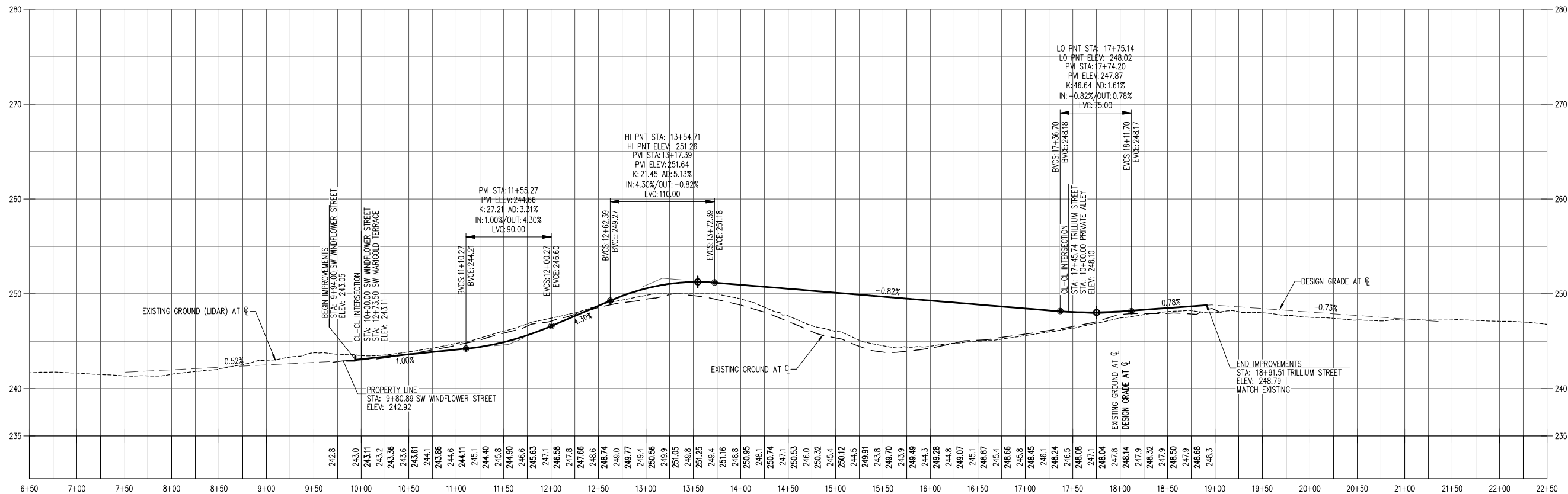

SW TRILLIUM STREET, SW YARROW LANE & SW WINDFLOWER STREET PROFILE
 HORZ. SCALE: 1" = 50'
 VERT. SCALE: 1" = 5'

PROFILE ELEVATION BASED ON CENTERLINE UNLESS NOTED OTHERWISE.

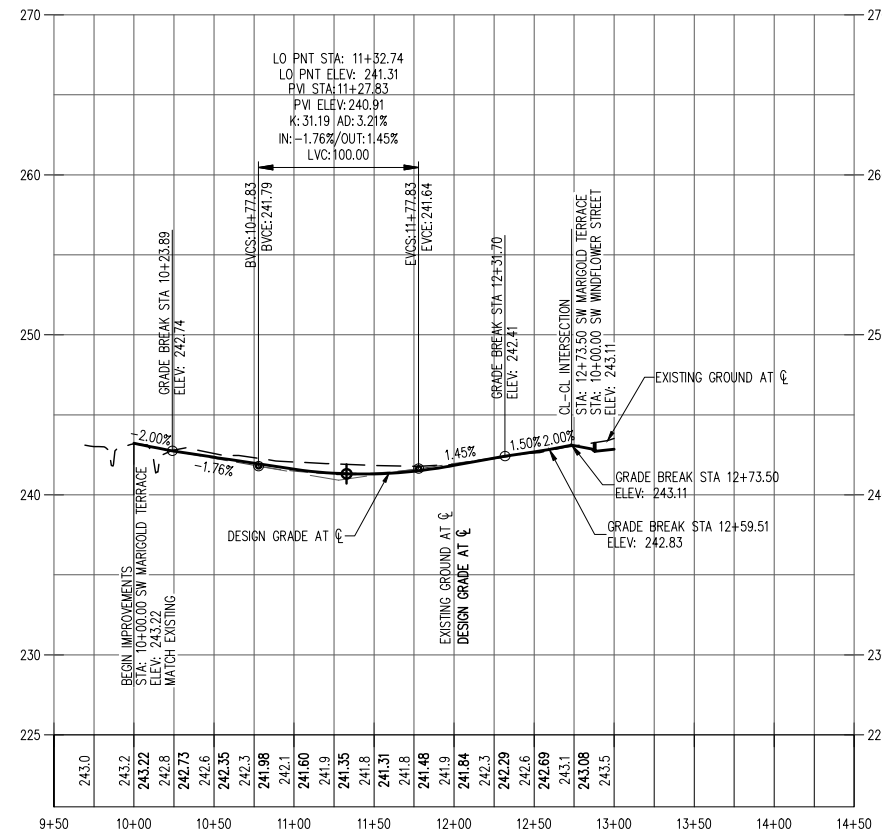

SW MARIGOLD TERRACE PROFILE
 HORZ. SCALE: 1" = 50'
 VERT. SCALE: 1" = 5'

PROFILE ELEVATION BASED ON CENTERLINE UNLESS NOTED OTHERWISE.

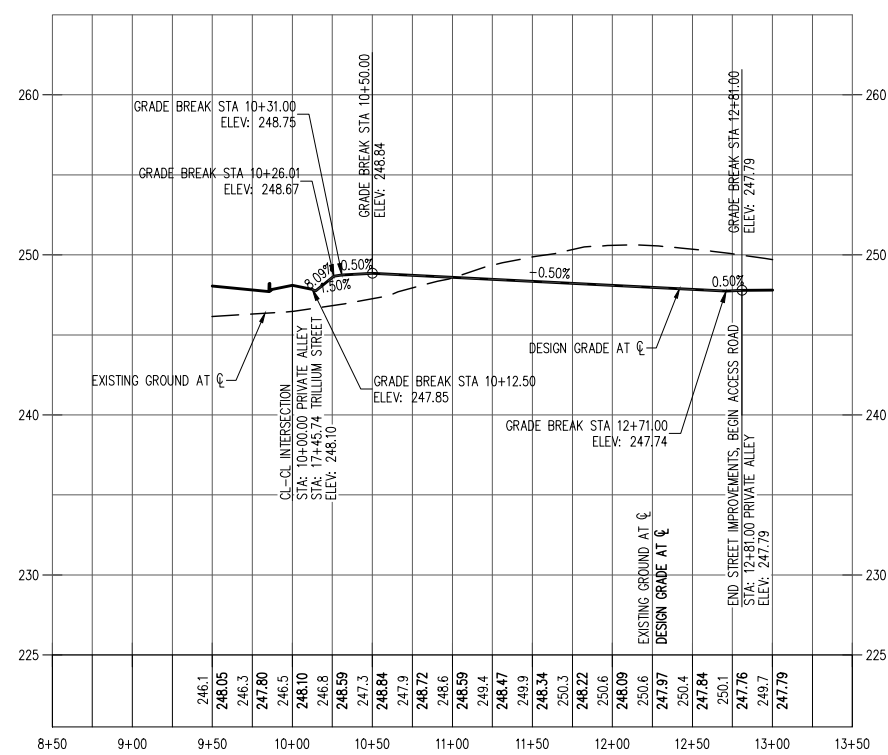

PRIVATE ALLEY PROFILE
 HORZ. SCALE: 1" = 50'
 VERT. SCALE: 1" = 5'

PROFILE ELEVATION BASED ON CENTERLINE UNLESS NOTED OTHERWISE.

PRELIMINARY STREET PROFILES
FROG POND CROSSING
VENTURE PROPERTIES, INC.
WILSONVILLE, OREGON



REVISIONS: DECEMBER 31, 2021

JOB NUMBER:	5252
DATE:	08/26/2021
DESIGNED BY:	AJD
DRAWN BY:	NLB
CHECKED BY:	MD

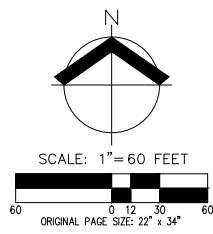

LEGEND

EXISTING GROUND CONTOUR (1 FT)	---	149
EXISTING GROUND CONTOUR (5 FT)	---	150
FINISHED GRADE CONTOUR (1 FT)	---	149
FINISHED GRADE CONTOUR (5 FT)	---	150
EXISTING CONIFEROUS TREE		
EXISTING DECIDUOUS TREE		
TREE REMOVAL		
TREE PROTECTION FENCE (TREE PROTECTION AREA)		
STRAW WATTLE		
ASSUMED TREE ROOT ZONE (1-FT RADIUS PER 1-IN OF DBH)		
EXISTING WETLAND		

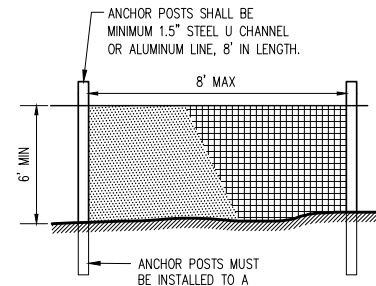

- NOTES:
- 2" MESH CHAIN LINK FENCE FOR TREE PROTECTION DEVICE OR APPROVED EQUAL.
 - AVOID DAMAGE TO CRITICAL ROOT ZONE. DO NOT DAMAGE OR SEVER LARGE ROOTS WHEN INSTALLING POSTS.
 - DEVICE SHALL BE MAINTAINED THROUGHOUT CONSTRUCTION.
- TREE PROTECTION FENCE**

SPECIAL PATH CONSTRUCTION NOTE:
 PEDESTRIAN PATH BEING PLACED NEAR TREES TO BE PRESERVED SHALL BE CONSTRUCTED BY STRIPPING GRASS/ORGANIC MATERIAL TO BARE SOIL, BEING CAREFUL NOT TO DAMAGE TREE ROOTS, AND THEN PLACING PATH CONSTRUCTION MATERIALS. EXCAVATION BEYOND STRIPPING GRASS/ORGANIC MATERIAL SHALL NOT OCCUR. IF NECESSARY TO LEVEL THE PATH, MINOR AMOUNTS OF FILL MATERIAL SHALL BE USED INSTEAD OF EXCAVATING SOIL. COMPACTION AND EQUIPMENT TRACK WALKING SHALL BE LIMITED AND CONFINED TO THE LIMITS OF THE PATH FOOTPRINT. A CERTIFIED ARBORIST SHALL BE ONSITE DURING PATH CONSTRUCTION WITHIN THE ASSUMED TREE ROOT ZONES.

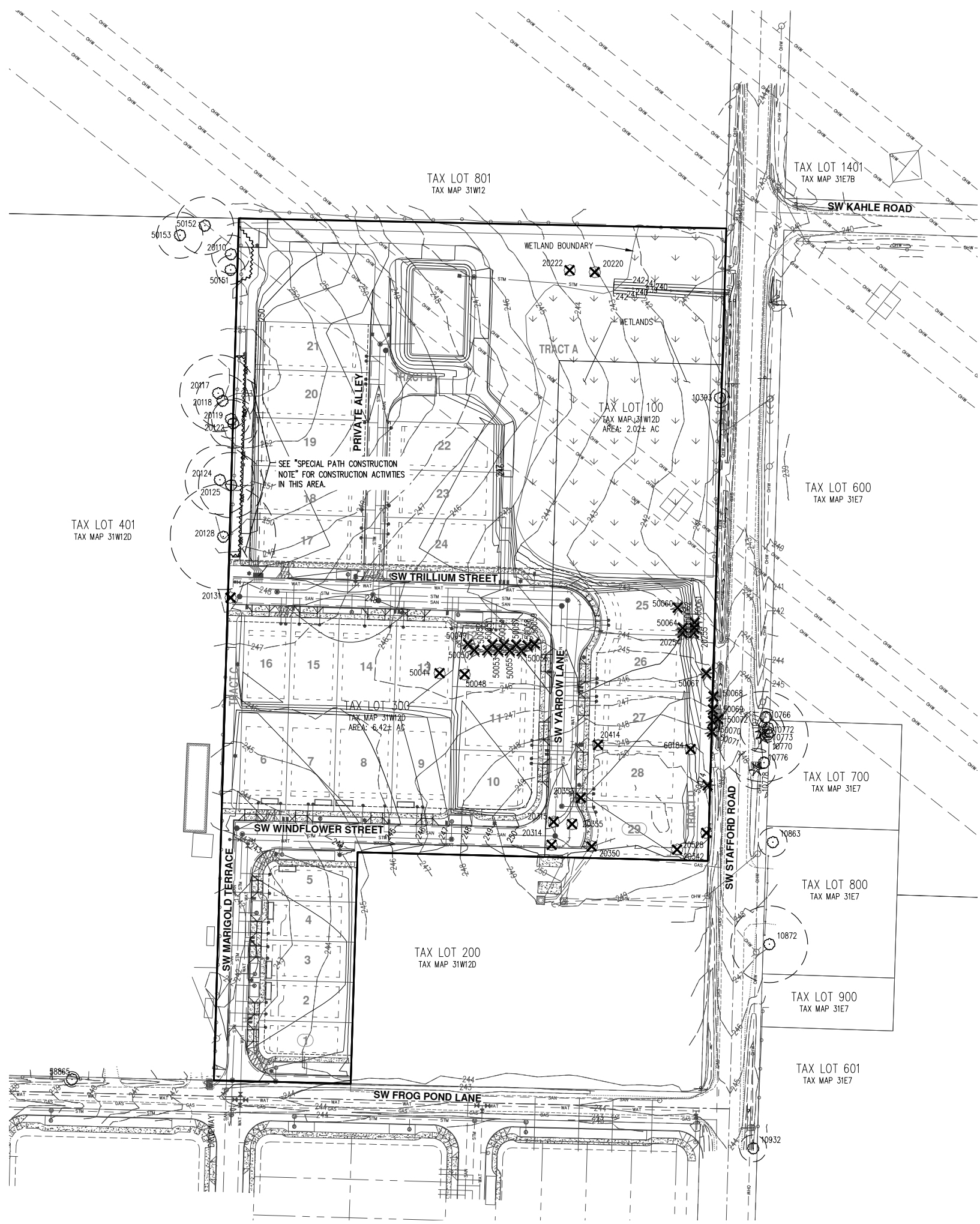

PRELIMINARY NOT FOR CONSTRUCTION

BRUCE R. BALDWIN
 CERTIFICATE NUMBER: PN-6666A
 EXPIRATION DATE: 12/31/23

PRELIMINARY TREE PRESERVATION AND REMOVAL PLAN
FROG POND CROSSING
VENTURE PROPERTIES, INC.
WILSONVILLE, OREGON

REGISTERED PROFESSIONAL ENGINEER	BRUCE R. BALDWIN
STATE OF OREGON	PN-6666A
EXPIRES 12/31/23	
RENEW: DECEMBER 31, 2021	
JOB NUMBER:	5252
DATE:	08/26/2021
DESIGNED BY:	AJD
DRAWN BY:	NLB
CHECKED BY:	MD

Detailed Tree Inventory for Frog Pond Crossing

AKS Job No. 5252 - Evaluation Date: 8/7/2020 & 6/11/2021 - Evaluated by: BRK

Tree #	DBH (in.)	Avg. Crown Radius (ft)	Tree Species (Common Name) (Scientific Name)	Comments	Health Rating*	Structure Rating**	Remove/Preserve
10191	10	17	Cherry (Prunus sp.)		1	1	Preserve
10166	8	16	Bogleaf Maple (Acer macrophyllum)	OFFSITE	1	1	Preserve
10170	17	20	Ponderosa Pine (Pinus ponderosa)	OFFSITE	1	1	Preserve
10171	23	20	Ponderosa Pine (Pinus ponderosa)	OFFSITE; 1 sided canopy (N); lean (N)	1	2	Preserve
10172	10	20	Bogleaf Maple (Acer macrophyllum)	OFFSITE; 1 sided canopy (E)	1	2	Preserve
10173	6,6,8,7	19	Bogleaf Maple (Acer macrophyllum)	OFFSITE; 1 sided canopy (E)	1	2	Preserve
10176	6,6	17	English Hawthorn (Crataegus monogyna)	OFFSITE	1	1	Preserve
10178	21	18	Ponderosa Pine (Pinus ponderosa)	OFFSITE; 1 sided canopy (W); Codominant	1	2	Preserve
10863	15,14,13,13,13,12,12,10,6	25	Bogleaf Maple (Acer macrophyllum)	OFFSITE	1	1	Preserve
10877	40	27	Nashville Catalpa (Catalpa speciosa)	OFFSITE	1	1	Preserve
10922	14	14	Apple (Malus domestica)	OFFSITE	1	1	Preserve
20110	20	20	Oregon White Oak (Quercus garryana)	OFFSITE; Evaluated from Property line; 1 sided canopy (N, lean E)	1	2	Preserve
20117	40	40	Oregon White Oak (Quercus garryana)	OFFSITE; Evaluated from Property line; lean (E)	1	2	Preserve
20118	26	25	Oregon White Oak (Quercus garryana)	OFFSITE; Evaluated from Property line; lean (W); 1 sided canopy (W)	1	2	Preserve
20119	20	25	Oregon White Oak (Quercus garryana)	OFFSITE; Evaluated from Property line	1	1	Preserve
20122	26	30	Oregon White Oak (Quercus garryana)	LINE TREE; Evaluated from Property line	1	1	Preserve
20124	16	27	Oregon White Oak (Quercus garryana)	OFFSITE; Evaluated from Property line; 1 sided canopy (W)	1	2	Preserve
20125	14	15	Oregon White Oak (Quercus garryana)	LINE TREE; Evaluated from Property line; 1 sided canopy (W); failed limbs (E)	2	2	Preserve
20128	55	35	Oregon White Oak (Quercus garryana)	OFFSITE; Evaluated from Property line	1	1	Preserve
20131	37	27	Oregon White Oak (Quercus garryana)	Evaluated from Property line; Abnormal dead branches; Broken branches; 50% loss coverage; sparse canopy	2	2	Remove
20220	10,9,7	13	English Hawthorn (Crataegus monogyna)	Dead branches	2	1	Remove
20222	6	6	English Hawthorn (Crataegus monogyna)		1	1	Remove
20254	7	10	Douglas fir (Pseudotsuga mucronata)		1	1	Remove
20255	16	16	Ponderosa Pine (Pinus ponderosa)		1	1	Remove
20214	6	10	Apple (Malus domestica)		1	1	Remove
20215	10,8	11	Apple (Malus domestica)	Large cavity with significant decay. On ground with epicormic stems	5	5	Remove
20342	10,8,6,9	0	Hazelnut (Corylus avellana)	Dead	3	3	Remove
20250	8,6,6	5	albatross		1	1	Remove
20251	17	18	Black Walnut (Juglans nigra)	Primary stem topped for overhead wires; Weakly attached leader; Significant decay	5	5	Remove
20255	40	0	Black Walnut (Juglans nigra)	Dead; 100% loss coverage	5	5	Remove
20414	15	16	Red Maple (Acer rubrum)		1	1	Remove
20528	46	30	Bogleaf Maple (Acer macrophyllum)	Scaffold branches; pruned for overhead wires; Severe; Broken branches with decay; Many leaders growing horizontal	2	2	Remove
50044	10,10	11	Apple (Malus domestica)	Bore holes, Cavity with insect frass	2	1	Remove
50048	16	17	Apple (Malus domestica)	Bore holes, Cavity with insect frass	2	1	Remove
50049	26	23	Ponderosa Pine (Pinus ponderosa)	Codominant top with included bark; 1 sided canopy (NW)	1	2	Remove
50050	27	20	Ponderosa Pine (Pinus ponderosa)	Codominant top with included bark; 1 sided canopy (SW); Many leaders at top	1	2	Remove
50051	27	22	Ponderosa Pine (Pinus ponderosa)	1 sided canopy (N); Codominant top	1	2	Remove
50052	15	15	Ponderosa Pine (Pinus ponderosa)	1 sided canopy (N); Codominant top; Broken branches	1	2	Remove
50053	27	17	Ponderosa Pine (Pinus ponderosa)	Dead	3	3	Remove
50054	11	11	Ponderosa Pine (Pinus ponderosa)	Suppressed; Codominant with included bark; Abnormal dead branches	2	2	Remove
50055	21	17	Ponderosa Pine (Pinus ponderosa)	1 sided canopy (N)	1	2	Remove
50056	19	15	Ponderosa Pine (Pinus ponderosa)	1 sided canopy (SE); Abnormal dead branches	2	2	Remove
50057	18	15	Ponderosa Pine (Pinus ponderosa)	1 sided canopy (N); Codominant top	1	2	Remove
50058	17	10	Ponderosa Pine (Pinus ponderosa)	Many abnormal dead branches; Very sparse canopy; In decline	5	5	Remove
50059	16	16	Black Walnut (Juglans nigra)	1 sided canopy (E)	1	2	Remove
50060	11	8	Ponderosa Pine (Pinus ponderosa)		1	1	Remove
50061	8	8	Ponderosa Pine (Pinus ponderosa)	Codominant top with included bark; Crooked top	1	2	Remove
50062	15	11	Ponderosa Pine (Pinus ponderosa)	Large scar at base with sap leakage	1	2	Remove
50064	14	11	Ponderosa Pine (Pinus ponderosa)		1	1	Remove
50067	47	16	Ponderosa Pine (Pinus ponderosa)	Last side pruned for overhead wires; Codominant top with included bark; 1 sided canopy (W); Some abnormal dead foliage	2	2	Remove
50068	17	11	Western Red Cedar (Thuja platanifolia)	OFFSITE; Topped for overhead wires; Abnormal dead branches	2	5	Remove
50069	15	11	Western Red Cedar (Thuja platanifolia)	LINE TREE; Topped for overhead wires; Abnormal dead branches	2	5	Remove
50070	11	13	Western Red Cedar (Thuja platanifolia)	OFFSITE; Topped for overhead wires; Abnormal dead branches	2	3	Remove
50071	14	11	Western Red Cedar (Thuja platanifolia)	OFFSITE; Topped for overhead wires; Abnormal dead branches	2	5	Remove
50072	17	15	Ponderosa Pine (Pinus ponderosa)	OFFSITE; Topped for overhead wires; Broken branches	2	3	Remove
60184	28	18	Bogleaf Maple (Acer macrophyllum)	Some scaffold branches; pruned for overhead wires; 1 sided canopy (W); Exposed roots with damage	2	2	Remove
50074	27	18	Blue Spruce (Picea pungens)	Topped for overhead wires; Weak leader to the (W); Abnormal dead branches; Exposed buttress roots (E)	2	3	Remove
50151	15	20	Oregon White Oak (Quercus garryana)	OFFSITE; Evaluated from Property line; 1 sided canopy (SE); lean (E)	1	2	Preserve
50152	10	27	Oregon White Oak (Quercus garryana)	OFFSITE; Evaluated from Property line; lean (N); Broken limbs with decay	2	2	Preserve
50153	24	25	Oregon White Oak (Quercus garryana)	OFFSITE; Evaluated from Property line; 1 sided canopy (SE); lean (E)	1	2	Preserve
58865	8	8	Oregon White Oak (Quercus garryana)	OFFSITE	1	1	Preserve

Total # of Existing Trees Invenoried = 61

Total # of Existing Onsite Trees = 34

Total # of Existing Onsite Trees to be Preserved = 1
 Total # of Existing Onsite Trees to be Removed = 33

Total # of Existing Line Trees = 3

Total # of Existing Line Trees to be Preserved = 2
 Total # of Existing Line Trees to be Removed = 1

Total # of Existing Offsite Trees = 24

Total # of Existing Offsite Trees to be Preserved = 20
 Total # of Existing Offsite Trees to be Removed = 4

***Health Rating:**

- 1 - Good Health - A tree that exhibits typical foliage, bark, and root characteristics, for its respective species, shows no signs of infection or infestation, and has a high level of vigor and vitality.
- 2 - Fair Health - A tree that exhibits some abnormal health characteristics and/or shows some signs of infection or infestation, but may be preserved or abated with supplemental treatment.
- 3 - Poor Health - A tree that is in significant decline, to the extent that supplemental treatment would not likely result in reversing or abating its decline.

****Structure Rating:**

- 1 - Good Structure - A tree that exhibits typical physical form characteristics, for its respective species, shows no signs of structural defects of the canopy, trunk, and/or root system.
- 2 - Fair Structure - A tree that exhibits some abnormal physical form characteristics and/or some signs of structural defects, which reduce the structural integrity of the tree, but are not indicative of imminent physical failure, and may be corrected using arboricultural abatement methods.
- 3 - Poor Structure - A tree that exhibits extensively abnormal physical form characteristics and/or significant structural defects that substantially reduce the structural stability of the tree, cannot feasibly be abated, and are indicative of imminent physical failure.

Arborist Disclosure Statement:

Arborists are tree specialists who use their education, knowledge, training, and experience to examine trees, recommend measures to enhance the health of trees, and attempt to reduce the risk of living near trees. The Client and landowner may choose to accept or disregard the recommendations of the arborist, or seek additional advice. Arborists cannot detect every condition that could possibly lead to the structural failure of a tree. Trees are living organisms that fail in ways we do not fully understand. Conditions are often hidden within trees and belowground. Arborists cannot guarantee that a tree will be healthy or safe under all circumstances, or for a specified period of time. Likewise, remedial treatments, like medicine, cannot be guaranteed. Trees can be managed, but they cannot be controlled. To live near trees is to accept some degree of risk. The only way to eliminate all risk associated with trees is to eliminate all trees. Neither this author nor AKS Engineering & Forestry, LLC have assumed any responsibility for liability associated with the trees on or adjacent to this site.

At the completion of construction, all trees should once again be reviewed, and clearing and removal of percent trees can expose previously unseen defects and otherwise healthy trees can be damaged during construction.

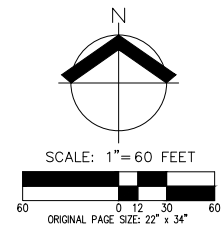

PRELIMINARY TREE PRESERVATION AND REMOVAL TABLE
FROG POND CROSSING
VENTURE PROPERTIES, INC.
WILSONVILLE, OREGON

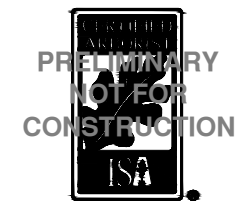

BRUCE R. BALDWIN
 CERTIFICATE NUMBER: PN-6666A
 EXPIRATION DATE: 12/31/21



RENEW: DECEMBER 31, 2021
 JOB NUMBER: 5252
 DATE: 08/26/2021
 DESIGNED BY: AJD
 DRAWN BY: NLB
 CHECKED BY: MD

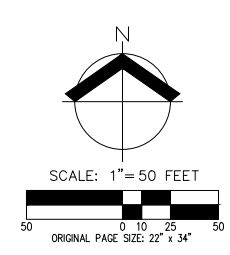
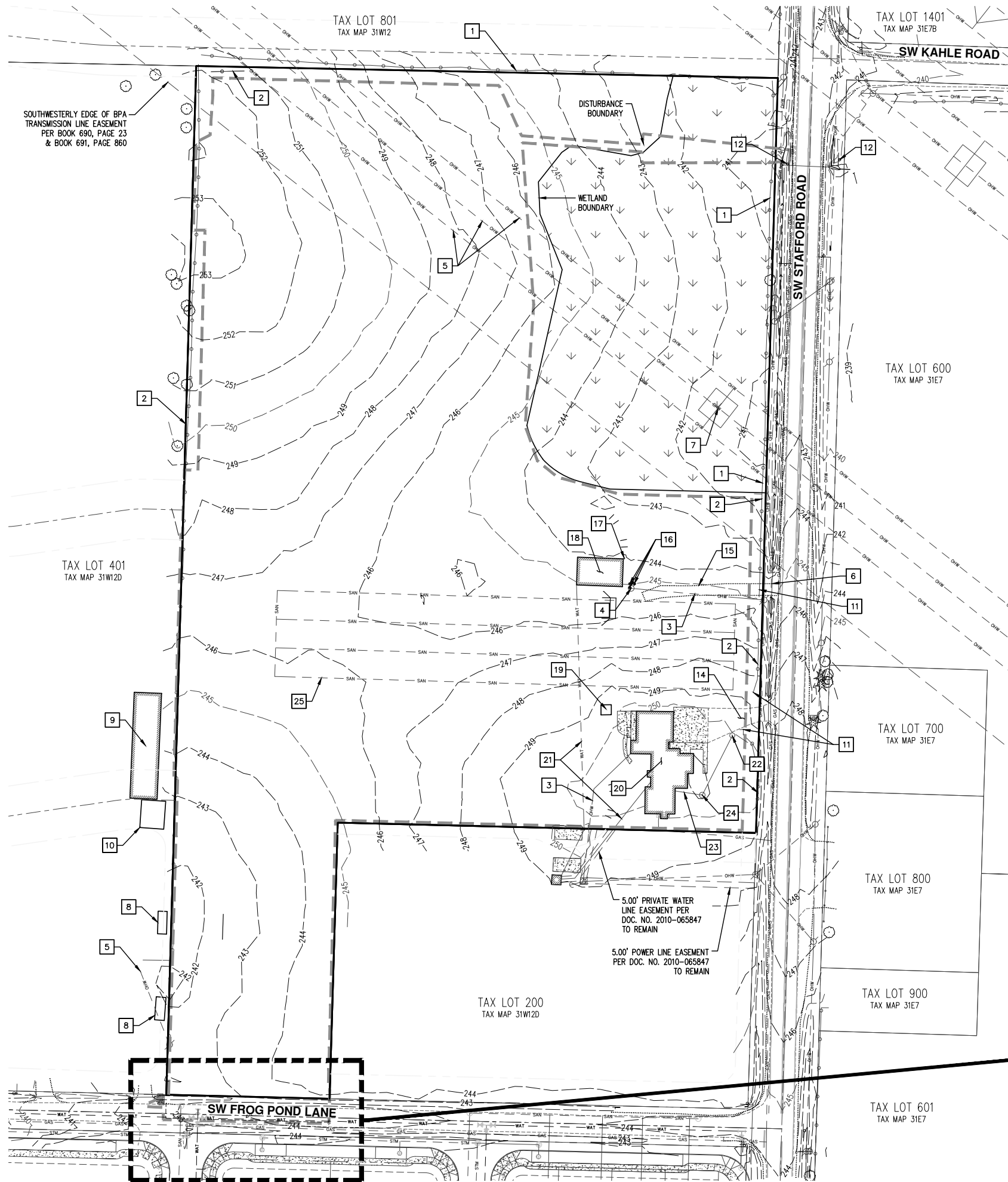

DEMOLITION KEYED NOTES

1. PRESERVE EXISTING FENCE.
2. REMOVE OR RELOCATE EXISTING FENCE. COORDINATE WITH PROPERTY OWNER.
3. REMOVE EXISTING OVERHEAD WIRE.
4. REMOVE EXISTING UTILITY POLE.
5. EXISTING OVERHEAD WIRE TO REMAIN.
6. EXISTING 15" DIA. STORM CULVERT TO REMAIN.
7. EXISTING TOWER TO REMAIN.
8. EXISTING CONEX BOX TO REMAIN.
9. EXISTING METAL FEEDER BARN TO REMAIN.
10. EXISTING RV CANOPY TO REMAIN.
11. EXISTING GATE TO BE REMOVED.
12. EXISTING SIGN TO REMAIN.
13. EXISTING MAILBOX TO BE RELOCATED.
14. REMOVE EXISTING DRIVEWAY.
15. REMOVE EXISTING GRAVEL ROAD.
16. REMOVE EXISTING BOLLARDS.
17. REMOVE EXISTING WOOD POSTS.
18. REMOVE EXISTING BARN STRUCTURE.
19. REMOVE EXISTING HUT.
20. REMOVE EXISTING HOUSE.
21. REMOVE EXISTING WATER LINE.
22. REMOVE EXISTING SANITARY CLEANOUT.
23. REMOVE EXISTING SANITARY LINE.
24. DECOMMISSION EXISTING SEPTIC TANK.
25. DECOMMISSION EXISTING SANITARY DRAIN FIELD.
26. REMOVE EXISTING ASPHALT.
27. SAWCUT LINE.

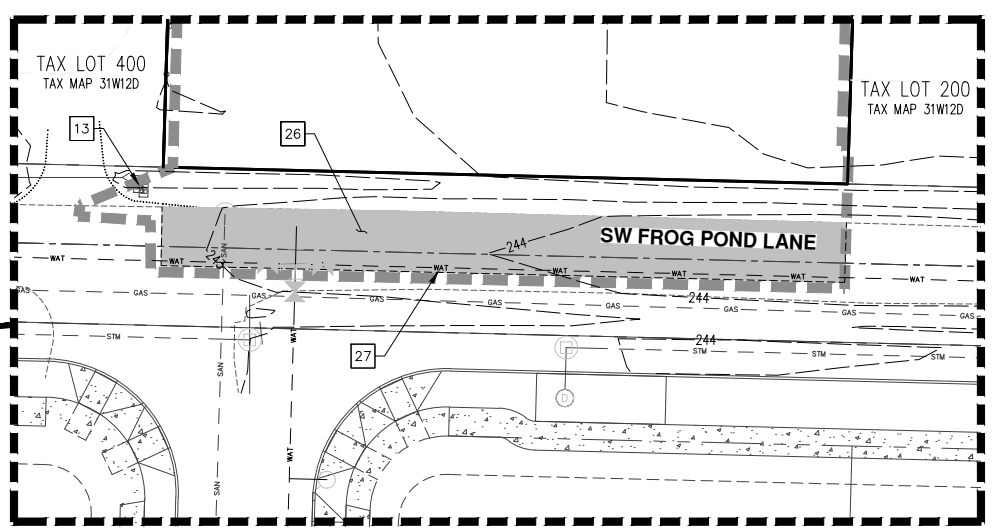
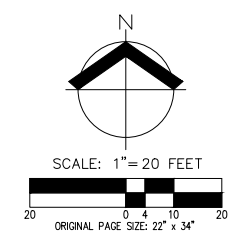
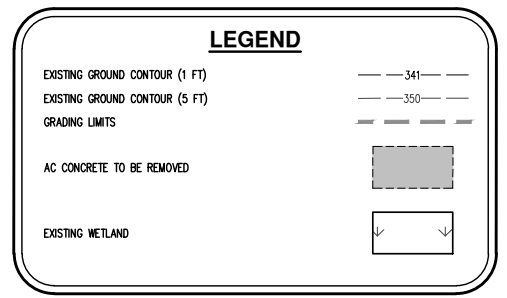

PRELIMINARY DEMOLITION PLAN
FROG POND CROSSING
VENTURE PROPERTIES, INC.
WILSONVILLE, OREGON

AKS
 AKS ENGINEERING & FORESTRY, LLC
 12965 SW HERMAN RD., STE. 100
 TUALATIN, OR 97062
 503.563.6151
 WWW.AKS-ENG.COM
 ENGINEERING • SURVEYING • NATURAL RESOURCES
 FORESTRY • PLANNING • LANDSCAPE ARCHITECTURE

REGISTERED PROFESSIONAL ENGINEER
 PRELIMINARY
 FOR CONSTRUCTION
 J. DOWNHUR
 RENEWS: DECEMBER 31, 2021
 JOB NUMBER: 5252
 DATE: 08/26/2021
 DESIGNED BY: AJD
 DRAWN BY: NLB
 CHECKED BY: MD



JOB NUMBER: 5252
 DATE: 08/26/2021
 DESIGNED BY: KAH
 DRAWN BY: ZTN
 CHECKED BY: KAH

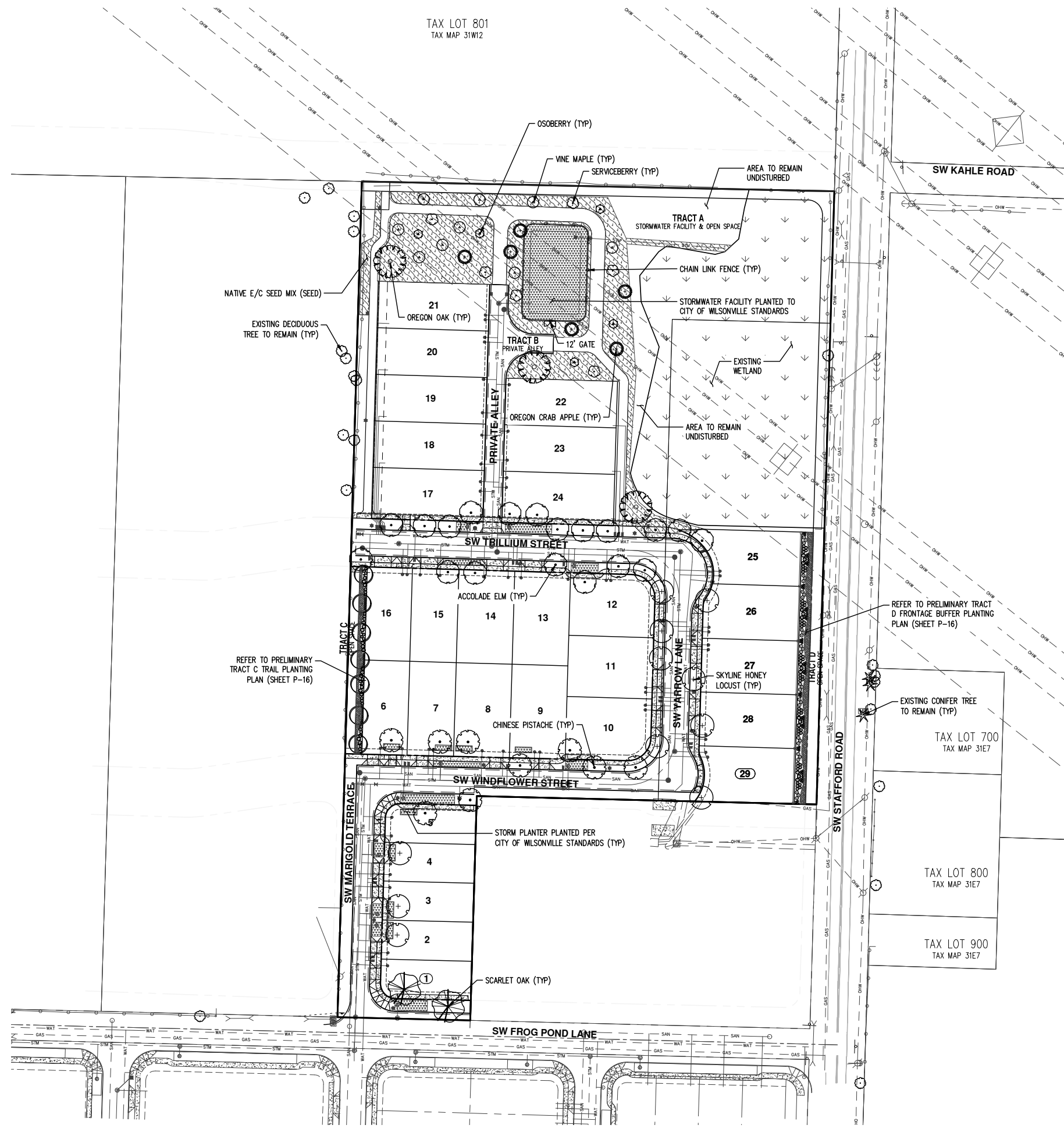

PRELIMINARY PLANT SCHEDULE

MITIGATION TREES	QTY	BOTANICAL NAME	COMMON NAME	SIZE/CONTAINER	SPACING
	9	ACER CIRCINATUM (NATIVE/LOW WATER USAGE)	VINE MAPLE	2" CAL. B&B (MULTI-STEM, CUMULATIVE TRUNKS)	AS SHOWN
	6	AMELANCHIER ALNIFOLIA (NATIVE/LOW WATER USAGE)	SERVICEBERRY	2" CAL. B&B (MULTI-STEM, CUMULATIVE TRUNKS)	AS SHOWN
	6	MALUS FUSCA (NATIVE/LOW WATER USAGE)	OREGON CRAB APPLE	2" CAL. B&B	AS SHOWN
	5	OEMLERIA CERASIFORMIS (NATIVE/LOW WATER USAGE)	OSOBERRY	2" CAL. B&B (MULTI-STEM, CUMULATIVE TRUNKS)	AS SHOWN
	3	QUERCUS CARRYANA (NATIVE/LOW WATER USAGE)	OREGON OAK	2" CAL. B&B	AS SHOWN
TOTAL MITIGATION REPLACEMENT TREES: 29					
STREET TREES	QTY	BOTANICAL NAME	COMMON NAME	SIZE/CONTAINER	SPACING
	11	GLEDTISIA TRIACANTHOS INERMIS 'SKYCOLE'™ (LOW WATER USAGE)	SKYLINE HONEY LOCUST	2" CAL. B&B	AS SHOWN
	9	PISTACIA CHINENSIS (LOW WATER USAGE)	CHINESE PISTACHE	2" CAL. B&B	AS SHOWN
	2	QUERCUS COCCINEA (LOW WATER USAGE)	SCARLET OAK	3" CAL. B&B	AS SHOWN
	19	ULMUS X 'MORTON'™ (MODERATE WATER USAGE)	ACCOLADE ELM	2" CAL. B&B	AS SHOWN
GROUND COVERS	DESCRIPTION				
	NATIVE E/C MIX (NATIVE/INTERIM WATER USAGE - PERMANENT IRRIGATION NOT PROPOSED)				
	SUNMARK SEEDS (OR APPROVED EQUAL) MEADOW BARLEY (HORDEUM BRACHYANTHERUM) 40%; CALIFORNIA BROME (BROMUS CARINATUS) 35%; NATIVE RED FESCUE (FESTUCA RUBRA RUBRA) 20%; TUFTED HAIRGRASS (DESCHAMPSIA CAESPITOSA) 3%; SPIKE BENTGRASS (AGROSTIS EXERATA) 2%				
	APPLY AT A RATE OF 1 LB PER 1,000 SF OR AT A RATE RECOMMENDED BY SUPPLIER. OBTAIN FROM SUNMARK SEEDS OR OTHER APPROVED SUPPLIER.				
	STORMWATER FACILITY PLANTED TO CITY OF WILSONVILLE STANDARDS (INTERIM WATER USAGE - PERMANENT IRRIGATION NOT PROPOSED)				

PRELIMINARY LANDSCAPE NOTES

- PLANTS AND PLANTINGS ARE PRELIMINARY AND SHOWN TO PORTRAY THE CHARACTER OF THE SITE. PLAN REVISIONS INCLUDING CHANGES TO PLANT SPECIES, SIZES, SPACING, QUANTITIES, ETC., DUE TO PLANT AVAILABILITY, FINAL FIELD LOCATIONS OF DRIVEWAYS, UTILITIES, ETC., OR UNFORESEEN SITE CONDITIONS, MAY BE MADE PRIOR TO INSTALLATION WHERE ALLOWED BY THE CITY OF WILSONVILLE DESIGN STANDARDS.
- ALL PLANTS AND INSTALLATION SHALL CONFORM TO THE CITY OF WILSONVILLE LANDSCAPE DESIGN STANDARDS AND TO THE AMERICAN STANDARD FOR NURSERY STOCK, ANSI Z60.1, CURRENT EDITION IN ALL WAYS. TREES AND OTHER LANDSCAPING PLANT MATERIAL SHALL BE WELL-BRANCHED AND TYPICAL FOR THE SPECIES, BEING FREE OF DAMAGE, DISEASE, OR PESTS.
- PLANT MATERIALS SHALL BE INSTALLED TO CURRENT INDUSTRY STANDARDS, SUCH AS THE BEST PRACTICE STANDARDS ADOPTED BY THE OREGON LANDSCAPE CONTRACTOR'S BOARD (OLCB).
- ALL TREES SHALL BE PROPERLY DOUBLE STAKED TO ASSURE SURVIVAL. SUPPORT DEVICES (GUY WIRES, ETC.) SHALL NOT BE ALLOWED TO INTERFERE WITH NORMAL PEDESTRIAN OR VEHICULAR MOVEMENT OR PLACED IN SUCH A WAY TO DAMAGE TREE BARK. CENTER TREE IN PLANTING STRIP BETWEEN CURB AND SIDEWALK WHERE APPLICABLE.
- LANDSCAPING WITHIN VISION CLEARANCE AREAS SHALL BE MAINTAINED TO THE STANDARDS OF SECTION 4.177. OF THE CITY'S DEVELOPMENT CODE.
- WATERING WILL BE PROVIDED FOR NEW PLANT ESTABLISHMENT AND LONG TERM PLANT HEALTH, THROUGH A PERMANENT, UNDERGROUND IRRIGATION SYSTEM (WATER EFFICIENT DRIP IRRIGATION AND/OR SPRAY IRRIGATION) WITHIN AUTOMATIC CONTROLLER, OR BY OTHER APPROVED METHODS. TEMPORARY IRRIGATION IN NATURAL AREAS, STORMWATER FACILITIES, ETC. MAY BE USED FOR INITIAL ESTABLISHMENT. THE IRRIGATION SYSTEM SHALL BE 'DESIGN-BUILD' BY THE LANDSCAPE CONTRACTOR, USING CURRENT WATER SAVING TECHNOLOGY, AND INCLUDE ALL MATERIALS, COMPONENTS, CITY APPROVED BACKFLOW OR ANTI-SIPHON DEVICES, VALVES, ETC. NECESSARY FOR THE COMPLETE AND EFFICIENT COVERAGE OF LANDSCAPE AREAS SHOWN. IRRIGATION AREAS SHALL BE APPROPRIATELY ZONED BASED ON WATER NEEDS (HIGH WATER USAGE, MODERATE WATER USAGE, LOW WATER USAGE, AND INTERIM (TEMPORARY) IRRIGATION).
- MULCH: APPLY 3" DEEP WELL-AGED DARK HEMLOCK, OR FIR, MEDIUM GRIND, UNDER AND AROUND ALL PLANTS IN PLANTING BEDS. WHERE TREES OR OTHER WOODY PLANT MATERIAL ARE PLANTED IN SEEDED AREAS, A MINIMUM 3" DIAMETER BARK MULCH SHALL BE USED AND CENTERED ON THE PLANT TRUNK FOR EASE OF MAINTENANCE AND SOIL MOISTURE RETENTION.

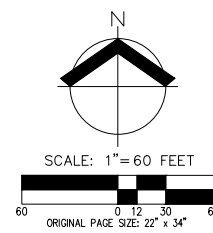

PRELIMINARY TRACT D FRONTAGE BUFFER PLANT SCHEDULE

SHRUBS	QTY	BOTANICAL NAME	COMMON NAME	SIZE/CONTAINER	SPACING
	15	EUONYMUS JAPONICUS 'SILVER KING' (MODERATE WATER USAGE)	SILVER KING EUONYMUS	2 GAL. CONT.	48" o.c.
	50	ILEX CRENATA 'COMPACTA' (MODERATE WATER USAGE)	DWARF JAPANESE HOLLY	2 GAL. CONT.	36" o.c.
	81	PENNISETUM ALOPECUROIDES 'HAMELN' (MODERATE WATER USAGE)	HAMELN FOUNTAIN GRASS	1 GAL. CONT.	24" o.c.
	30	ROSA X 'NOARE' TM (MODERATE WATER USAGE)	FLOWER CARPET RED ROSE	2 GAL. CONT.	42" o.c.
GROUND COVERS	QTY	BOTANICAL NAME	COMMON NAME	SIZE/CONTAINER	SPACING
	355	RUBUS CALYCNOIDES 'EMERALD CARPET' (MODERATE WATER USAGE)	EMERALD CARPET CREEPING BRAMBLE	4" POTS	24" o.c.

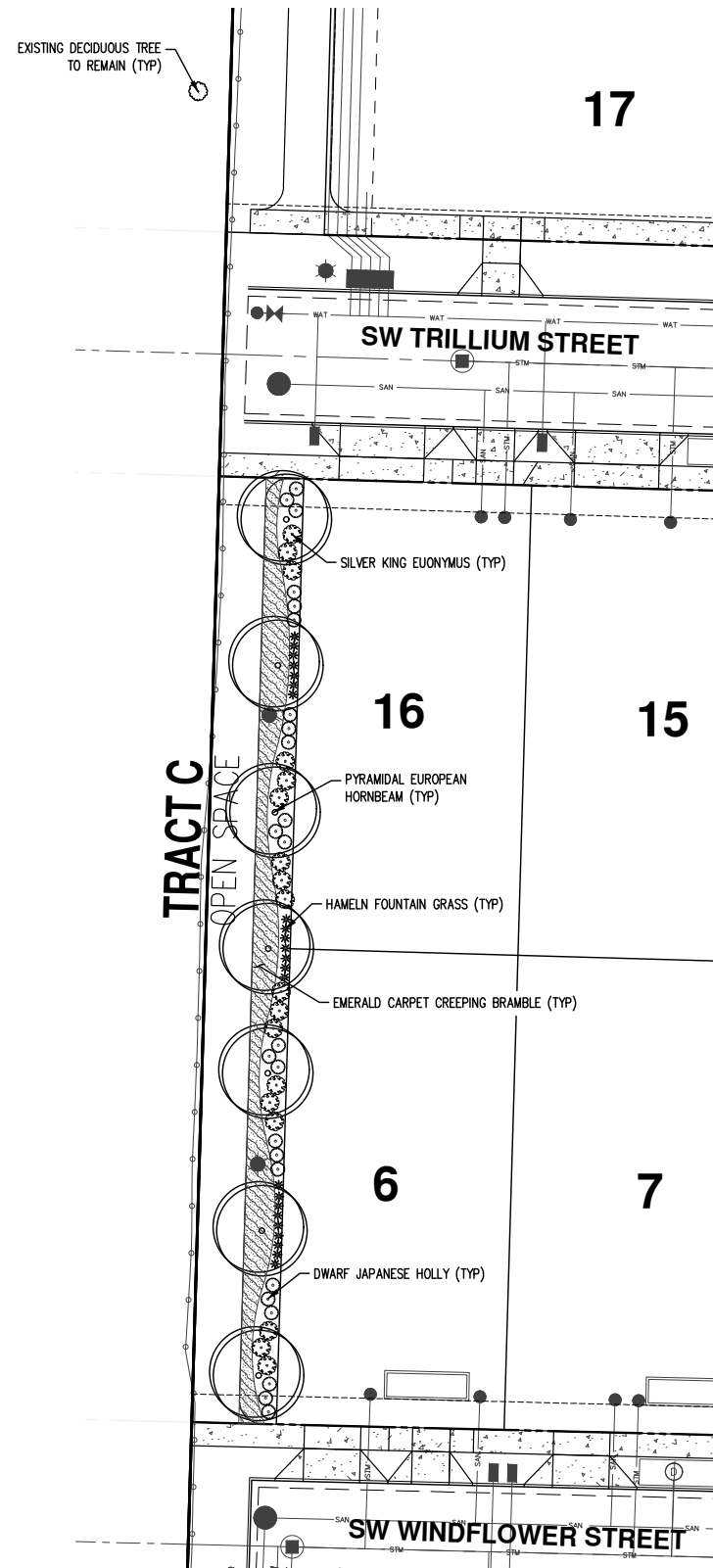
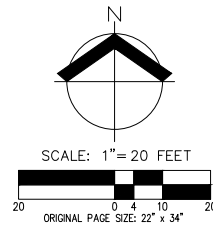

TRACT C TRAIL
SCALE: 1" = 20'

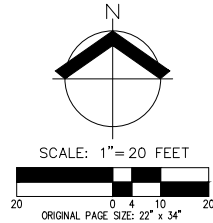

PRELIMINARY TRACT C TRAIL PLANT SCHEDULE

TREES	QTY	BOTANICAL NAME	COMMON NAME	SIZE/CONTAINER	SPACING
	7	CARPINUS BETULUS 'FASTIGIATA' (MODERATE WATER USAGE)	PYRAMIDAL EUROPEAN HORNBEAN	2" CAL. B&B	AS SHOWN
SHRUBS	QTY	BOTANICAL NAME	COMMON NAME	SIZE/CONTAINER	SPACING
	18	EUONYMUS JAPONICUS 'SILVER KING' (MODERATE WATER USAGE)	SILVER KING EUONYMUS	2 GAL. CONT.	48" o.c.
	24	ILEX CRENATA 'COMPACTA' (MODERATE WATER USAGE)	DWARF JAPANESE HOLLY	2 GAL. CONT.	36" o.c.
	23	PENNISETUM ALOPECUROIDES 'HAMELN' (MODERATE WATER USAGE)	HAMELN FOUNTAIN GRASS	1 GAL. CONT.	24" o.c.
GROUND COVERS	QTY	BOTANICAL NAME	COMMON NAME	SIZE/CONTAINER	SPACING
	215	RUBUS CALYCNOIDES 'EMERALD CARPET' (MODERATE WATER USAGE)	EMERALD CARPET CREEPING BRAMBLE	4" POTS	24" o.c.

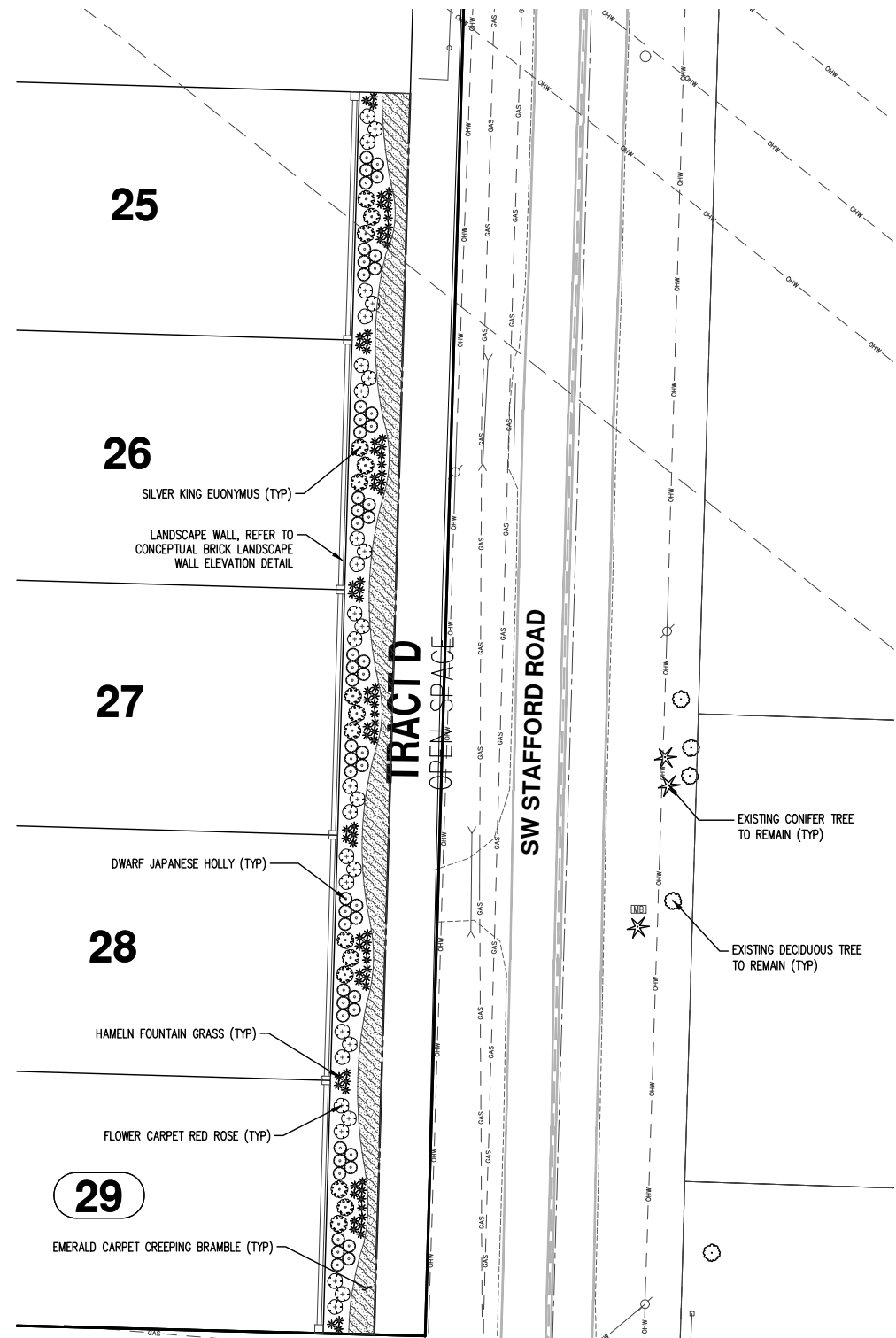

TRACT D FRONTAGE
SCALE: 1" = 20'



JOB NUMBER:	5252
DATE:	08/26/2021
DESIGNED BY:	KAH
DRAWN BY:	NKP
CHECKED BY:	KAH

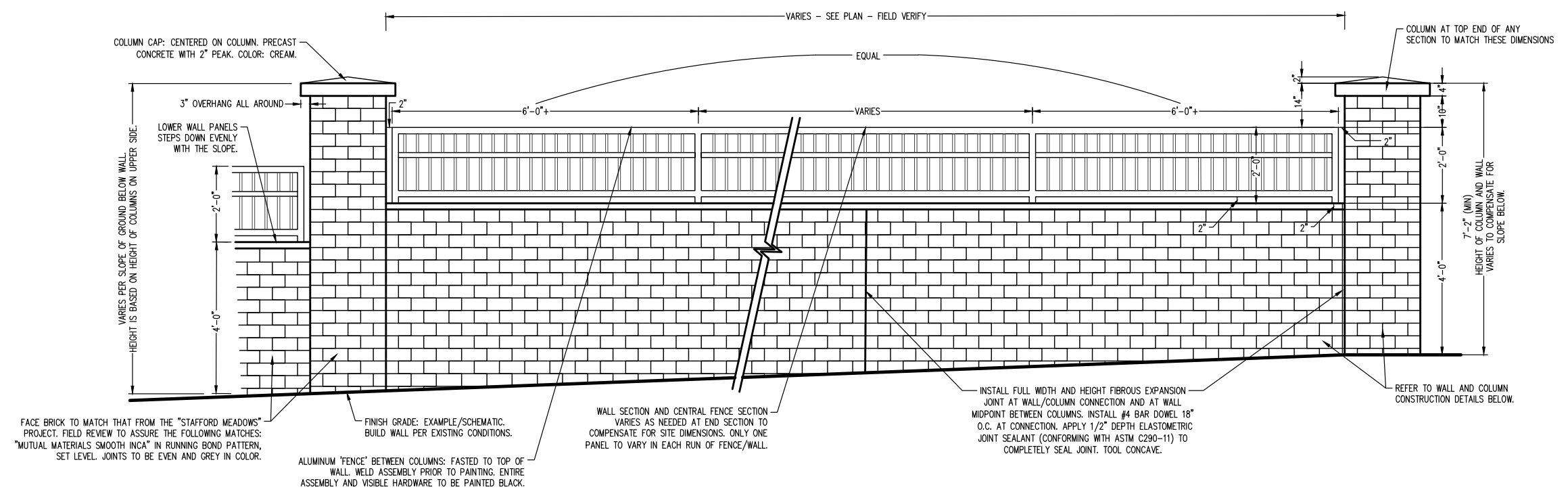

1 CONCEPTUAL BRICK LANDSCAPE WALL ELEVATION DETAIL

- P-17** NTS
 NOTE:
 1. THIS WALL TO MATCH THE EXISTING WALL, IN REGARDS TO COLORS AND MATERIALS. FACE BRICK TO MATCH THAT FROM THE "STAFFORD MEADOWS" PROJECT. FIELD REVIEW TO ASSURE THE FOLLOWING MATCHES: FACE BRICK TO BE "MUTUAL MATERIALS SMOOTH INCA" IN RUNNING BOND PATTERN, SET LEVEL. JOINTS TO BE EVEN AND GREY COLOR. COLUMN CAP TO BE PRECAST CONCRETE WITH 2" PEAK, CREAM IN COLOR.
 2. INSTALL FULL WIDTH AND HEIGHT FIBROUS EXPANSION JOINT AT WALL/COLUMN CONNECTION AND AT WALL MIDPOINT BETWEEN COLUMNS. INSTALL #4 BAR DOWEL 18" O.C. AT CONNECTION. APPLY 1/2" DEPTH ELASTOMETRIC JOINT SEALANT (CONFORMING WITH ASTM C290-11) TO COMPLETELY SEAL JOINT. TOOL CONCAVE.
 3. ALUMINUM "FENCE" BETWEEN COLUMNS: FASTED TO TOP OF WALL. WELD ASSEMBLY PRIOR TO PAINTING. ENTIRE ASSEMBLY AND VISIBLE HARDWARE TO BE PAINTED BLACK.
 4. ALL TO BE PLUMB, ALIGNED, CENTERED, AND SQUARE.
 5. "FENCE", WALL CAP, AND BRICK TO BE LEVEL.
 6. HEIGHT OF COLUMN AND WALL VARIES TO COMPENSATE FOR SLOPE BELOW. TO BE 7'-2" MINIMUM.

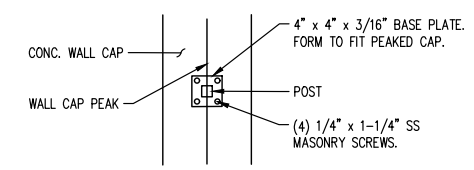

2 CONCEPTUAL FENCE POST MOUNT PLAN DETAIL

P-17 NTS

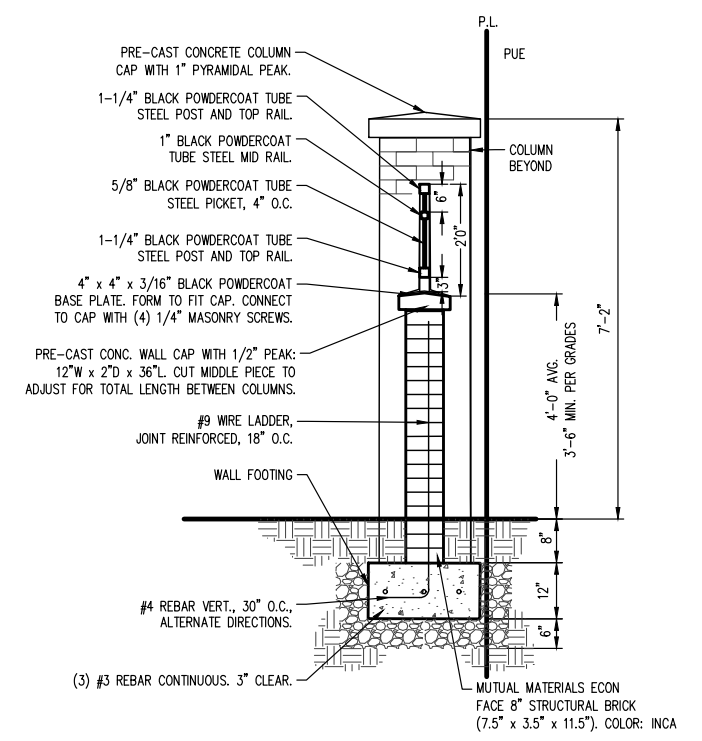

3 CONCEPTUAL BRICK LANDSCAPE WALL SECTION DETAIL

P-17 NTS

PRELIMINARY FRONTAGE WALL DETAILS
FROG POND CROSSING
VENTURE PROPERTIES, INC.
WILSONVILLE, OREGON



JOB NUMBER:	5252
DATE:	08/26/2021
DESIGNED BY:	KAH
DRAWN BY:	NKP
CHECKED BY:	KAH

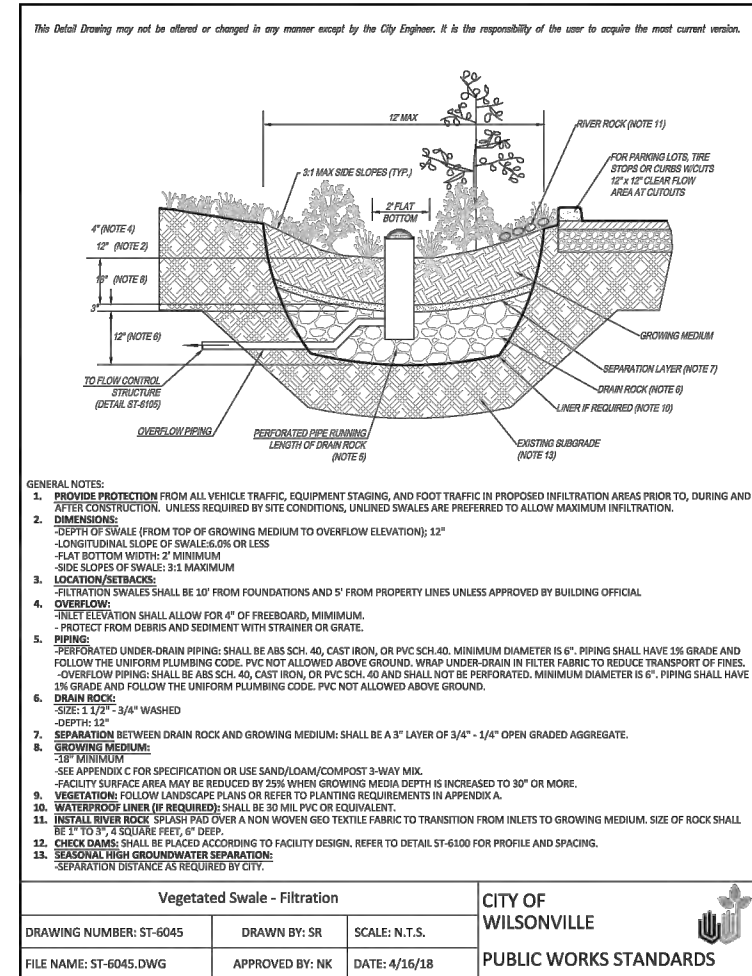
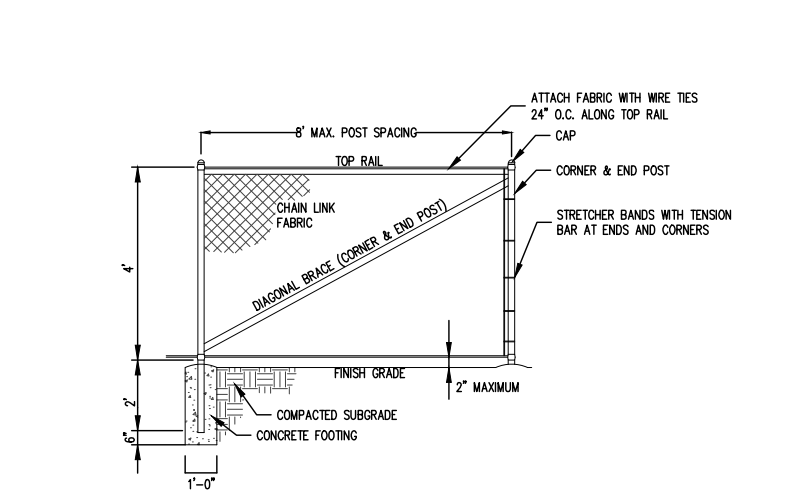
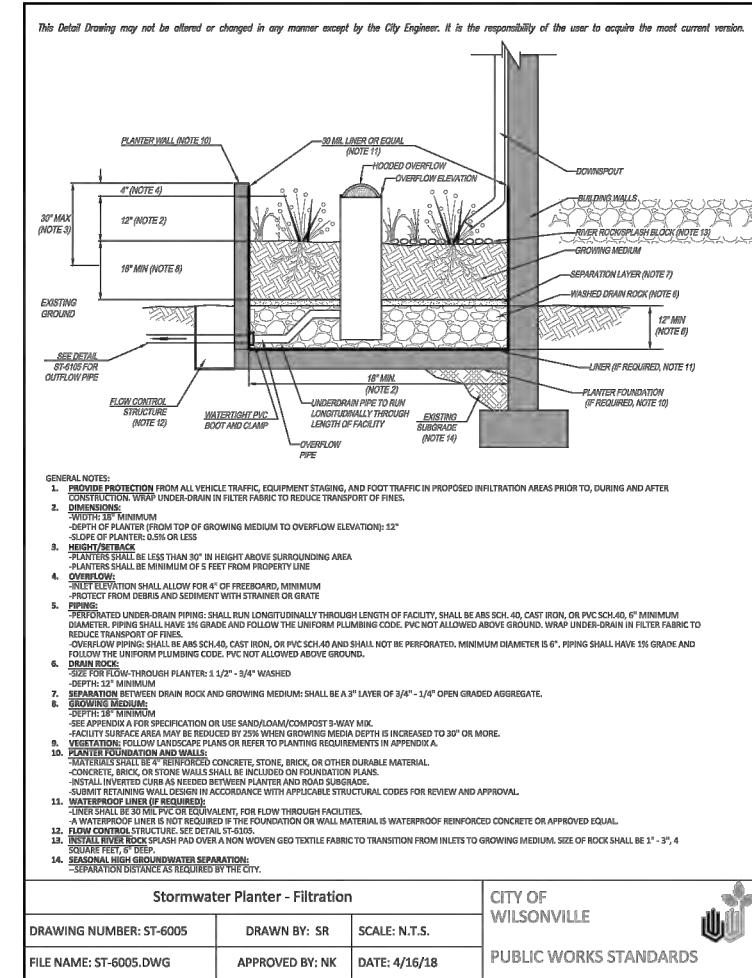
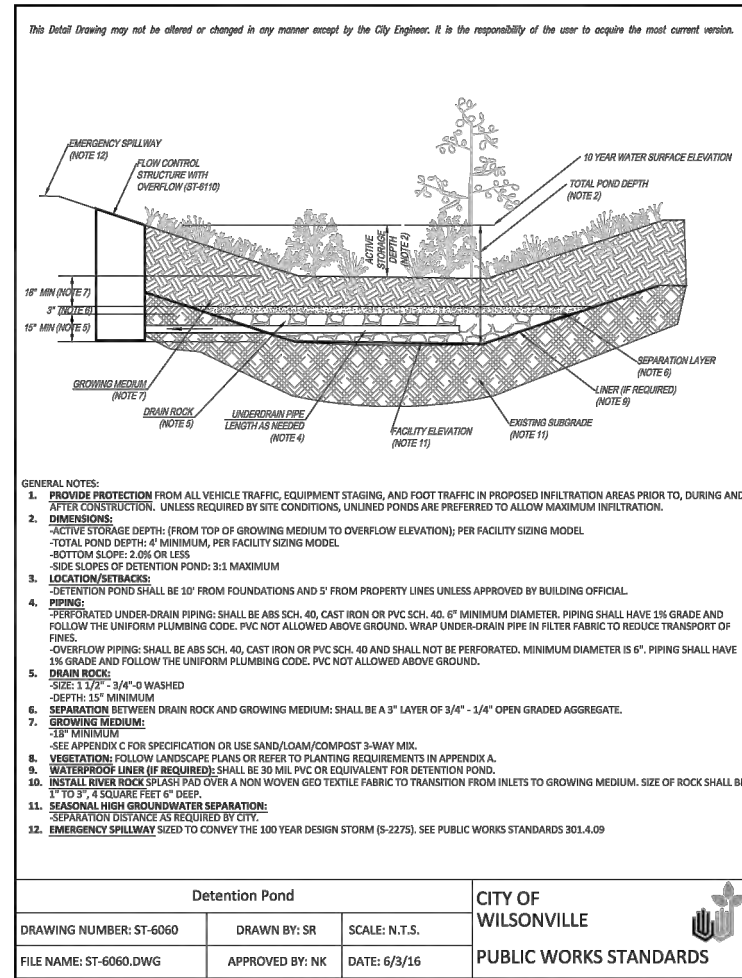
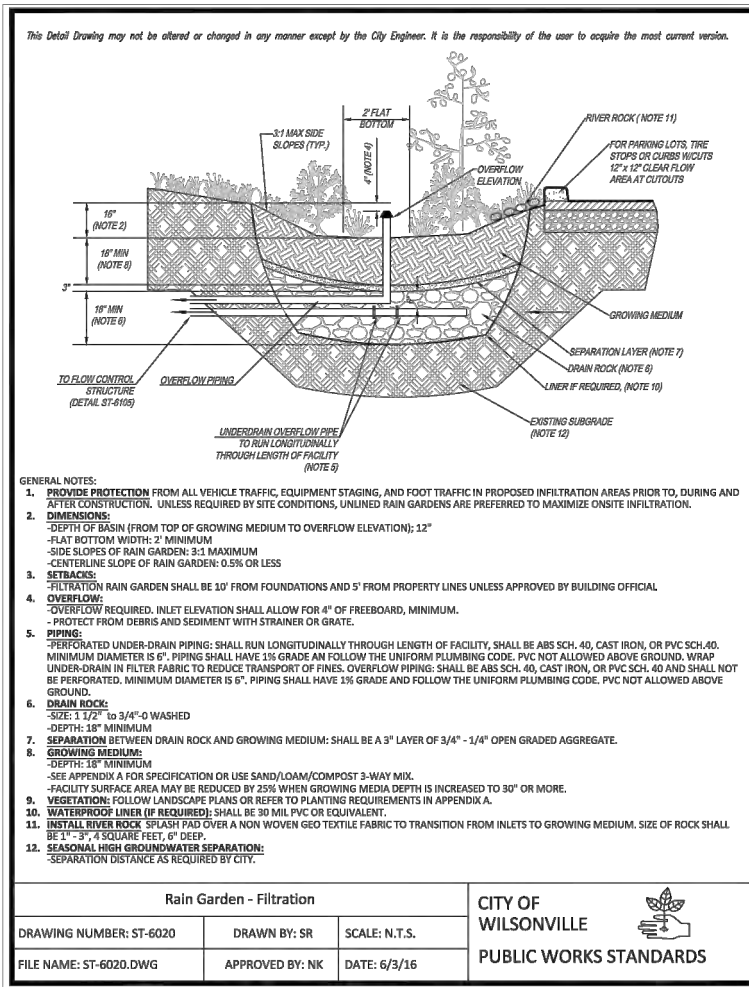

Exhibit B: Land Use Application Forms



29799 SW Town Center Loop E, Wilsonville, OR 97070
 Phone: 503.682.4960 Fax: 503.682.7025
 Web: www.ci.wilsonville.or.us

**Planning Division
 Development Permit Application**

Final action on development application or zone change is required within 120 days in accordance with provisions of ORS 227.175

A pre application conference is normally required prior to submittal of an application. Please visit the City's website for submittal requirements

Pre-Application Meeting Date: 12/12/2019

Incomplete applications will not be scheduled for public hearing until all of the required materials are submitted.

Applicant:

Name: Venture Properties, Inc.
 Company: _____
 Mailing Address: 4230 Galewood St #100
 City, State, Zip: Lake Oswego, OR 97035
 Phone: please contact the Applicant's consultant
 E-mail: please contact the Applicant's consultant

Authorized Representative:

Name: Consultant: Mimi Doukas, AICP, RLA
 Company: AKS Engineering & Forestry, LLC
 Mailing Address: 12965 SW Herman Rd., Suite 100
 City, State, Zip: Tualatin, OR 97062
 Phone: 503-563-6151 Fax: 503-563-6152
 E-mail: mimid@aks-eng.com

Property Owner:

Name: Paul C. Chaney and Janene C. Chaney,
 Company: Co-Trustees of the Paul C. Chaney and Janene Paris Chaney RL
 Mailing Address: 27227 SW Stafford Rd.
 City, State, Zip: Wilsonville, OR 97070
 Phone: please contact the Applicant's consultant
 E-mail: please contact the Applicant's consultant

Property Owner's Signature:

Janene P. Chaney Trustee
PAUL C CHANEY
 Printed Name: JANEVE PARIS CHANEY Date: 4/29/2021

Applicant's Signature: (if different from Property Owner)

DocuSigned by:
Kelly Ritz
DE4436E8BFA5444
 Printed Name: Kelly Ritz Date: 4/28/2021

Site Location and Description:

Project Address if Available: 27227 SW Stafford Rd. Suite/Unit _____
 Project Location: southwest corner of SW Stafford Rd. and SW Kahle Rd.
 Tax Map #(s): 31 W 12D Tax Lot #(s): 100, 300, 302 County: Washington Clackamas

Request:

Annexation, Zoning Map Amendment, Planned Development (Stage I Master Plan, Stage II Final Plan), Site Design Review of Open Space, Tentative Subdivision Plat, Type C Tree Removal Plan, Waiver for R5 Subdistrict Open Space Location

Project Type: Class I **Class II** **Class III**

Residential Commercial Industrial Other: _____

Application Type(s):

<input checked="" type="checkbox"/> Annexation	<input type="checkbox"/> Appeal	<input type="checkbox"/> Comp Plan Map Amend	<input type="checkbox"/> Parks Plan Review
<input type="checkbox"/> Final Plat	<input type="checkbox"/> Major Partition	<input type="checkbox"/> Minor Partition	<input type="checkbox"/> Request to Modify Conditions
<input type="checkbox"/> Plan Amendment	<input checked="" type="checkbox"/> Planned Development	<input checked="" type="checkbox"/> Preliminary Plat	<input checked="" type="checkbox"/> Site Design Review
<input type="checkbox"/> Request for Special Meeting	<input type="checkbox"/> Request for Time Extension	<input type="checkbox"/> Signs	<input checked="" type="checkbox"/> Stage II Final Plan
<input type="checkbox"/> SROZ/SRIR Review	<input type="checkbox"/> Staff Interpretation	<input checked="" type="checkbox"/> Stage I Master Plan	<input type="checkbox"/> Variance
<input checked="" type="checkbox"/> Type C Tree Removal Plan	<input type="checkbox"/> Tree Permit (B or C)	<input type="checkbox"/> Temporary Use	<input type="checkbox"/> Other (describe)
<input type="checkbox"/> Villebois SAP	<input type="checkbox"/> Villebois PDP	<input type="checkbox"/> Villebois FDP	
<input checked="" type="checkbox"/> Zone Map Amendment	<input checked="" type="checkbox"/> Waiver(s)	<input type="checkbox"/> Conditional Use	

Exhibit C: Title Report



01351400200900731240040044

10/15/2009 03:44:51 PM

\$62.00

D-D Cnt=1 Str=2 JANISKEL
\$20.00 \$10.00 \$16.00 \$16.00

4p

AFTER RECORDING, RETURN TO:
SEND TAX STATEMENTS TO:

PAUL & JANENE CHANEY

27227 SW STAFFORD RD

WILSONVILLE, OR 97070

STATUTORY BARGAIN AND SALE DEED
(Lot Line Adjustment)

PAUL C. CHANEY and JANENE C. CHANEY, CO-TRUSTEES OF THE PAUL C. CHANEY and JANENE PARIS CHANEY RLT, Grantor, conveys to PAUL C. CHANEY and JANENE C. CHANEY, CO-TRUSTEES OF THE PAUL C. CHANEY and JANENE PARIS CHANEY RLT, Grantee, the following described real property situated in Clackamas County, State of Oregon, to wit:

SEE ATTACHED EXHIBIT A

BEFORE SIGNING OR ACCEPTING THIS INSTRUMENT, THE PERSON TRANSFERRING FEE TITLE SHOULD INQUIRE ABOUT THE PERSON'S RIGHTS, IF ANY, UNDER ORS 197.300, 195.301 AND 305 TO 195.336 AND SECTIONS 5 TO 11, CHAPTER 424, OREGON LAWS 2007. THIS INSTRUMENT DOES NOT ALLOW USE OF THE PROPERTY DESCRIBED IN THIS INSTRUMENT IN VIOLATION OF APPLICABLE LAND USE LAWS AND REGULATIONS. BEFORE SIGNING OR ACCEPTING THIS INSTRUMENT, THE PERSON ACQUIRING FEE TITLE TO THE PROPERTY SHOULD CHECK WITH THE APPROPRIATE CITY OR COUNTY PLANNING DEPARTMENT TO VERIFY THAT THE UNIT OF LAND BEING TRANSFERRED IS A LAWFULLY ESTABLISHED LOT OR PARCEL, AS DEFINED IN ORS 92.010 OR 215.010, TO VERIFY THE APPROVED USES OF THE LOT OR PARCEL, TO DETERMINE ANY LIMITS ON LAWSUITS AGAINST FARMING OR FOREST PRACTICES AS DEFINED IN ORS 30.930 AND TO INQUIRE ABOUT THE RIGHTS OF NEIGHBORING PROPERTY OWNERS, IF ANY, UNDER ORS 195.300, 195.301 AND 195.305 TO 195.336 AND SECTIONS 5 TO 11, CHAPTER 424, OREGON LAWS 2007

The true consideration for this conveyance in terms of actual dollars is NONE. The purpose of this deed is to complete a lot line adjustment of between portions of those properties acquired by deed recorded July 26, 2001, Fee No. 2001-058932, by deed recorded July 26, 2001, Fee No. 2001-58933, and by deed recorded August 18, 2009, Fee No. 2009-059361, pursuant to

Clackamas County Department of Transportation and Development Case File No. Z0339-09-PLA. Combines Tax Account 31W12D 0300, 31W12D 301, with portions of 31W12D 0200 and 31W12D 0201.

Dated: SEPT. 23, 2009

Paul C. Chaney, Co-Trustee

Paul C. Chaney, Co-Trustee
Paul C. Chaney and Janene Paris Chaney RLT

Janene C. Chaney, Co-Trustee

Janene C. Chaney, Co-Trustee
Paul C. Chaney and Janene Paris Chaney RLT

STATE OF Oregon)
) ss.
COUNTY OF Clackamas)

On this 23rd day of September, 2009, personally appeared the herein Paul C. Chaney, Co-Trustee of the Paul C. Chaney and Janene Paris Chaney RLT who acknowledged the herein instrument to be his voluntary act and deed.

Before me:

Katie Frahm

NOTARY PUBLIC FOR THE STATE OF OREGON

My Commission Expires: November 23, 2011



STATE OF Oregon)
) ss.
COUNTY OF Clackamas)

On this 23rd day of September, 2009, personally appeared the herein Janene Paris Chaney, Co-Trustee of the Paul C. Chaney and Janene Paris Chaney RLT who acknowledged the herein instrument to be her voluntary act and deed.

Before me:



NOTARY PUBLIC FOR THE STATE OF OREGON

My Commission Expires: November 23, 2011



ANDY PARIS & ASSOCIATES, INC.
REGISTERED PROFESSIONAL LAND SURVEYORS

PROPERTY: Tax Lots 300, 301 and other - Assessor's Map No. 3 1W 12D

LOCATION: Stafford Road

DATE: September 4, 2009

PROJECT: 09055

Clackamas County Planning File No. Z0339-09-PLA

Tract 1

FOR USE ON LEGAL INSTRUMENT

EXHIBIT "A"

A tract of land situated in the Southeast one-quarter of Section 12, Township 3 South, Range 1 West of the Willamette Meridian, Clackamas County, Oregon, being more particularly described as follows:

Commencing at a 3-1/4" diameter bronze monument marking the southeast corner of said Section 12; thence North 00°04'48" East along the east line of said Section 12 a distance of 1749.00 feet; thence leaving said east line, South 89°48'48" West a distance of 395.00 feet to a found 5/8" iron rod with yellow plastic cap stamped "ANDY PARIS & ASSOC., INC" and **TRUE POINT OF BEGINNING**, said point being on the northerly right of way line of Frogpond Lane (County Road No. 2362); thence leaving said right of way line, North 00°04'48" East parallel with the east line of said Section 12 a distance of 241.00 feet to a found 5/8" iron rod with yellow plastic cap stamped "ANDY PARIS & ASSOC., INC"; thence North 89°48'48" East a distance of 195.00 to a set 1-5/32 inch copper disk stamped "PARIS & ASSOC."; thence North 00°04'48" East parallel with the east line of said Section 12 a distance of 517.00 feet to a set 5/8" iron rod with yellow plastic cap stamped "ANDY PARIS & ASSOC., INC"; thence North 89°48'48" East a distance of 170.00 feet to a set 5/8" iron rod with yellow plastic cap stamped "ANDY PARIS & ASSOC., INC" on the westerly right of way line of Stafford Road (Market Road No. 12; thence North 00°04'48" East along said westerly right of way line a distance of 141.81 feet to the north line of the southeast one-quarter of said Section 12; thence leaving said right of way line, South 89°37'48" West along said north line of the southeast one-quarter a distance of 477.51 feet; thence leaving said north line, South 00°04'48" West a distance of 30.33 feet; thence South 89°48'48" West a distance of 30.00 feet to the most westerly northwest corner of that certain tract of land conveyed to Paul C. Chaney and Janene C. Chaney as recorded in Fee No. 2001-002679, Clackamas County Deed records; thence South 00°04'48" West parallel with the east line of said Section 12 and along the westerly line of said Chaney tract a distance of 867.95 feet to the northerly right of way line of said Frogpond Lane; thence North 89°48'48" East along said right of way line a distance of 142.50 feet to the **True Point of Beginning**.

Containing 6.42 acres, more or less.

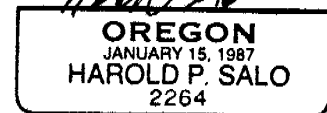

16057 BOONES FERRY RD. LAKE OSWEGO, OR. 97035
PHONE: 503-636-3341 • FAX: 503-636-0477

(u)



SPECIAL WARRANTY DEED

KNOW ALL MEN BY THESE PRESENTS, That Andrew J. Paris and Dorothy M. Paris as individuals, and Andrew J. Paris and Dorothy M. Paris, as Co-Trustees* for the consideration hereinafter stated, does hereby grant, bargain, sell and convey unto PAUL C. CHANEY and JANENE C. CHANEY, husband and wife hereinafter called grantee, and unto grantee's heirs, successors and assigns all of that certain real property with the tenements, hereditaments and appurtenances thereunto belonging or in any way appertaining, situated in the County of CLACKAMAS, State of Oregon, described as follows, to-wit:

*of the ANDREW J. and DOROTHY M. PARIS TRUST

SEE LEGAL DESCRIPTION ATTACHED AND MADE A PART HEREOF

**In fulfillment of that certain real estate contract dated September 24, 1982 and recorded October 1, 1982 under fee number 82-27235 records of Clackamas County, OR.

(IF SPACE INSUFFICIENT, CONTINUE DESCRIPTION ON REVERSE SIDE)

To Have and to Hold the same unto the grantee and grantee's heirs, successors and assigns forever.

And the grantor hereby covenants to and with the grantee and grantee's heirs, successors and assigns that the real property is free from encumbrances created or suffered thereon by grantor and that grantor will warrant and defend the same and every part and parcel thereof against the lawful claims and demands of all persons claiming by, through, or under the grantor.

The true and actual consideration paid for this transfer, stated in terms of dollars, is \$62,640.00**

However, the actual consideration consists of or includes other property or value given or promised which is the whole consideration (indicate which). (The sentence between the symbols, if not applicable, should be deleted. See ORS 93.030.)

In construing this deed, where the context so requires, the singular includes the plural and all grammatical changes shall be made so that this deed shall apply equally to corporations and to individuals.

In Witness Whereof, the grantor has executed this instrument this 11 day of JAN, 1990, if a corporate grantor, it has caused its name to be signed and its seal, if any, affixed by an officer or other person duly authorized thereto by order of its board of directors.

THIS INSTRUMENT WILL NOT ALLOW USE OF THE PROPERTY DESCRIBED IN THIS INSTRUMENT IN VIOLATION OF APPLICABLE LAND USE LAWS AND REGULATIONS BEFORE SIGNING OR ACCEPTING THIS INSTRUMENT, THE PERSON ACQUIRING FEE TITLE TO THE PROPERTY SHOULD CHECK WITH THE APPROPRIATE CITY OR COUNTY PLANNING DEPARTMENT TO VERIFY APPROVED USES AND TO DETERMINE ANY LIMITS ON LAWSUITS AGAINST FARMING OR FOREST PRACTICES AS DEFINED IN ORS 30.930.

Handwritten signatures of Andrew J. Paris and Dorothy M. Paris, with printed names and titles: Andrew J. Paris, Co-Trustee; Dorothy M. Paris, Co-Trustee.

STATE OF OREGON, County of Clackamas ss. This instrument was acknowledged before me on 1-11-1990 by Andrew J. Paris and Dorothy M. Paris. This instrument was acknowledged before me on 1-11-1990 by Andrew J. Paris and Dorothy M. Paris as Co-Trustees of the Andrew J. and Dorothy M. Paris Trust

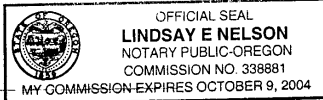

Handwritten signature of Lindsay E. Nelson, Notary Public for Oregon. My commission expires

Andrew and Dorothy Paris 16877 SW Canyon Drive Lake Oswego, OR 97034 Grantor's Name and Address Paul and Janene Chaney 27227 SW Stafford Rd Wilsonville, OR 97070 Grantee's Name and Address After recording return to (Name, Address, Zip): Paul and Janene Chaney 27227 SW Stafford Rd Wilsonville, OR 97070 Until requested otherwise send all tax statements to (Name, Address, Zip): Above Grantee

STATE OF OREGON, County of } ss. RECORDED IN CLACKAMAS COUNTY JOHN KAUFFMAN, COUNTY CLERK 2001-002679 \$31.00 01/16/2001 09:50:12 AM D-D Cnt=1 Str=4 RECORDER \$10.00 \$11.00 \$10.00 witness my hand and seal of County affixed. 20012679 By _____, Deputy

A tract of land situated in the S.E. ¼ of Section 12, T.3S., R. 1W., of the W.M., being a part of that certain tract of land described in Book 394, page 696. and Book 642, page 884, Deed Records, Clackamas County, Oregon, being more particularly described as follows, to wit:

Beginning at a 5/8" iron rod in the northerly right of way line of Frog Pond Road (County Road No. 2362), which iron rod bears N. along the easterly line of said Section 12, 1749.00 feet and S. 89°44'W. parallel with the S. line of said Section 12, 272.81 feet from the S.E. corner of said Section 12. From said place of beginning; thence leaving said northerly right of way line of Frog Pond Road, N. parallel with the easterly line of said Section 12, 899.03 feet to a 5/8" iron rod in the N. line of the S.E. ¼ of said Section 12, T.3S., R.1W., of the W.M.; thence S. 89°33'W. along said N. line of the S.E. ¼, 234.89 feet to a 5/8" iron rod; thence leaving said ¼ section line, S, 30.13 feet to a 5/8" iron rod; thence S. 89°44'W. parallel with the S. line of said Section 12, 30.00 feet to a 5/8" iron rod; thence S. along the westerly line of said tract described in Book 642. page 884, and parallel with the easterly line of said Section 12, 867.94 feet (Deed 858.00 feet) to a 5/8" iron rod in the northerly right of way line of said Frog Pond Road; thence N. 89°44'E. along the northerly right of way line of said Frog Pond Road, 264.89 feet to the place of beginning. Containing 5.44 acres, more or less.

SUBJECT TO power line easement as recorded in Book 690, page 23, and Book 691, page 860, Deed Records.

②

Exhibit D: Clackamas County Assessor's Map

3 1 W 12D
WILSONVILLE

S.E. 1/4 SEC. 12 T.3S. R.1W. W.M.
CLACKAMAS COUNTY
1" = 200'

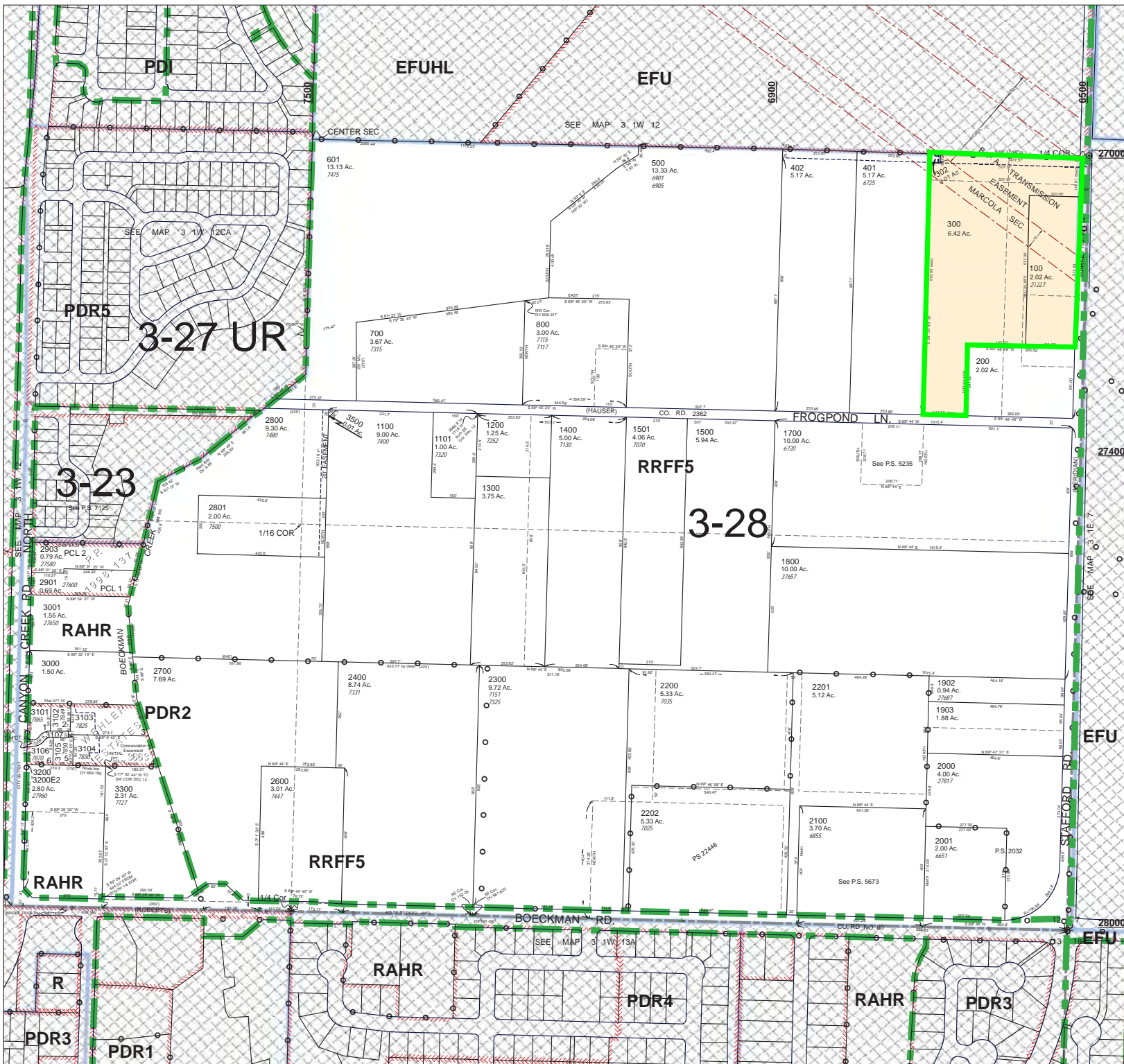

Cancelled Taxlots

- 201
- 301
- 400
- 600
- 602
- 603
- 604
- 605
- 800
- 1000
- 1600
- 1900
- 1901
- 2000E1
- 2500
- 2900S1
- 2900
- 2902
- 3100
- 3200E1
- 3201
- 3300E1
- 3400
- 3200E3

- Parcel Boundary
- - - Private Road ROW
- - - Historical Boundary
- Railroad Centerline
- TaxCodeLines
- Map Index
- WaterLines
- Land Use Zoning
- Plats
- Water
- Corner
- Section Corner
- 1/16th Line
- Govt Lot Line
- DLC Line
- Meander Line
- PLSS Section Line
- ⊗ Historic Corridor 40'
- ⊗ Historic Corridor 20'

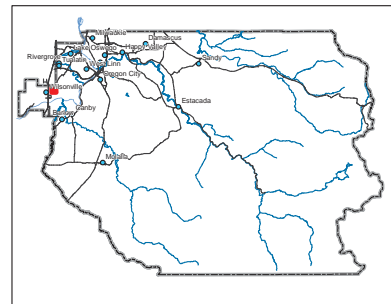

THIS MAP IS FOR ASSESSMENT
PURPOSES ONLY



8/20/2018

3 1 W 12D
WILSONVILLE

Exhibit E: Traffic Impact Study



FROG POND

**WILSONVILLE FROG POND WEST
CROSSING SUBDIVISION**
TRANSPORTATION IMPACT ANALYSIS

AUGUST 2021

PREPARED FOR:



117 COMMERCIAL STREET NE, SUITE 310, SALEM, OR 97301 • 503.391.8773 • DKSASSOCIATES.COM

PREPARED FOR CITY OF WILSONVILLE



PREPARED BY DKS ASSOCIATES

Scott Mansur, P.E., PTOE

Jenna Bogert, P.E.

Travis Larson, E.I.



TABLE OF CONTENTS

INTRODUCTION.....	5
EXISTING CONDITIONS.....	7
STUDY AREA ROADWAY NETWORK.....	7
EXISTING TRAFFIC VOLUMES.....	8
INTERSECTION PERFORMANCE MEASURES.....	9
EXISTING INTERSECTION OPERATIONS	11
PROJECT IMPACTS.....	12
PROPOSED DEVELOPMENT.....	12
FUTURE ANALYSIS SCENARIOS	12
TRIP GENERATION	12
VEHICLE TRIP DISTRIBUTION	13
FUTURE TRAFFIC VOLUMES	13
FUTURE INTERSECTION OPERATIONS.....	18
MITIGATION & FUNDING	19
SITE REVIEW	20
SUMMARY OF PROJECT IMPACTS.....	22
APPENDIX	23
A. TRAFFIC COUNT DATA.....	24
B. HCM REPORTS – EXISTING.....	25
C. STAGE II LIST	26
D. HCM REPORTS – EXISTING + PROJECT	27
E. HCM REPORTS – EXISTING + STAGE II	28
F. HCM REPORTS – EXISTING + PROJECT + STAGE II	29
G. SITE PLAN	31

LIST OF FIGURES

FIGURE 1: STUDY AREA	6
FIGURE 2: 2021 EXISTING PM TRAFFIC VOLUMES, LANE GEOMETRIES, AND TRAFFIC CONTROL	10
FIGURE 3: TRIP DISTRIBUTION AND PROJECT TRIPS	14
FIGURE 4: EXISTING PM + PROJECT PEAK HOUR TRAFFIC VOLUMES	15
FIGURE 5: EXISTING PM + STAGE II PEAK HOUR TRAFFIC VOLUMES.....	16
FIGURE 6: EXISTING PM + PROJECT + STAGE II PEAK HOUR TRAFFIC VOLUMES.....	17

LIST OF TABLES

TABLE 1: STUDY AREA AND PROPOSED PROJECT CHARACTERISTICS	5
TABLE 2: STUDY AREA ROADWAY CHARACTERISTICS	7
TABLE 3: EXISTING PM INTERSECTION OPERATIONS	11
TABLE 4: VEHICLE TRIP GENERATION	13
TABLE 5: EXISTING PM, PROJECT, AND STAGE II INTERSECTION OPERATIONS.....	18

INTRODUCTION

This study evaluates the transportation impacts associated with the proposed Frog Pond West Crossing Subdivision development to be located on Frog Pond Lane in Wilsonville, Oregon. The owner desires to construct 29 single-family homes as part of the Frog Pond West Master Plan.¹

The purpose of this transportation impact analysis is to identify potential mitigation measures needed to offset transportation impacts that the proposed development may have on the nearby transportation network. The impact analysis is focused on the study intersections, which were selected for evaluation in coordination with City staff. The intersections are listed below and shown on Figure 1.

- Boeckman Road/ Parkway Avenue
- Boeckman Road/ Canyon Creek Road
- Boeckman Road/ Stafford Road/ Advance Road/ Wilsonville Road
- Stafford Road/ Frog Pond Lane
- Stafford Road/ 65th Avenue

Table 1 lists important characteristics of the study area and proposed project.

TABLE 1: STUDY AREA AND PROPOSED PROJECT CHARACTERISTICS

STUDY AREA	
NUMBER OF STUDY INTERSECTIONS	Five
ANALYSIS PERIODS	Weekday PM peak hour (highest hour between 4pm – 6pm)
PROPOSED DEVELOPMENT	
SIZE AND LAND USE	8.45-acre plot with 29 residential house lots
NET PROJECT TRIPS	31 total PM peak hour trips (19 in, 12 out)
VEHICLE ACCESS POINTS	Access to the site will be provided via Frog Pond Lane, with an alternate access via Willow Creek Drive.

¹ Frog Pond West Master Plan, City of Wilsonville, July 17, 2017.



FIGURE 1: STUDY AREA

EXISTING CONDITIONS

This chapter provides documentation of existing study area conditions, including the study area roadway network, pedestrian and bicycle facilities, and existing traffic volumes and operations.

STUDY AREA ROADWAY NETWORK

Key roadways and their existing characteristics in the study area are summarized in Table 2. The functional classifications for the streets are provided in the City of Wilsonville Transportation System Plan (TSP).²

TABLE 2: STUDY AREA ROADWAY CHARACTERISTICS

ROADWAY	FUNCTIONAL CLASSIFICATION	ROADWAY OWNERSHIP	POSTED SPEED	SIDEWALKS	BIKE FACILITIES	ON-STREET PARKING
FROG POND LANE	Collector	City of Wilsonville	N/A	No	No	No
STAFFORD ROAD	Major Arterial	Clackamas County	45 mph	No	No	No
BOECKMAN ROAD	Minor Arterial	City of Wilsonville	35 mph	Partial ^a	Partial ^a	No
WILSONVILLE ROAD	Minor Arterial	City of Wilsonville	35 mph	Yes	Yes	No
ADVANCE ROAD	Collector	City of Wilsonville ^b	35 mph ^c	Partial ^d	Partial ^d	No
CANYON CREEK ROAD	Minor Arterial	City of Wilsonville	35 mph	Yes	Yes	No
PARKWAY AVENUE	Minor Arterial	City of Wilsonville	40 mph	Yes	Partial ^e	No
65 TH AVENUE	Minor Arterial	Clackamas County and Washington County ^f	45 mph	No	No	No

^a Sidewalk primarily exists on south side of street. Bicycle lanes are intermittent.

^b City jurisdiction west of 60th Avenue. County jurisdiction east of 60th Avenue.

^c Speed limit increases to 45 mph outside of the City.

^d Sidewalk and bike lane present on the south side between Stafford Road and 63rd Avenue.

^e Intermittent bike lanes.

^f West half is Washington County; east half is Clackamas County.

² Wilsonville Transportation System Plan, Amended November 16, 2020.

NEARBY BICYCLE AND PEDESTRIAN FACILITIES

There are currently no bicycle lanes or sidewalks along Frog Pond Lane or Stafford Road to connect the new development with the City pedestrian and bicycle system. Willow Creek Drive, a collector road currently in construction within the Frog Pond West area, will have sidewalks and bicycle lanes on both sides of the street. Along Boeckman Road and Advance Road, sidewalks exist on the south side and there are intermittent bicycle lanes. Wilsonville Road has bicycle lanes and sidewalks on both sides of the street.

NEARBY PUBLIC TRANSIT SERVICE

South Metro Area Regional Transit (SMART) provides public transportation services within Wilsonville and the outlying areas. There are no bus stops currently adjacent to Frog Pond Lane, but Route 4 covers Advance Road and Wilsonville Road with the closest stop to the project site approximately 0.5 mile south at Landover Road on Wilsonville Road.

PLANNED PROJECTS

The City of Wilsonville Transportation System Plan (TSP) has a list of Higher Priority projects which includes the recommended projects reasonably expected to be funded through 2035. These are the highest priority solutions to meet the City's most important needs. The list includes the following projects that impact the key roadways near the proposed project site.³

- RE-12A - Frog Pond West Neighborhood Collector Roads: Construction of collector roadways within the Frog Pond West neighborhood per the Master Plan.
- RW-01 - Boeckman Road Bridge and Corridor Improvements: Improvements along Boeckman Road near I-5 as well as improvement of the Parkway Avenue intersection.
- UU-01 - Boeckman Road Dip Improvements: Installation of bridge along Boeckman Road at the vertical curve and a new traffic signal at the Boeckman Road/ Canyon Creek Road intersection.
- UU-06 - Stafford Road Urban Upgrade: Upgrade of Stafford Road from Kahle Road to Boeckman Road to applicable roadway cross-section standards.
- SI-03 - Stafford Road/65th Avenue Intersection Improvements: New signal or roundabout in conjunction with 65th/Elligsen intersection to facilitate improved safety and operations.
- BW-04 - Boeckman Road Bike Lanes and Sidewalk Infill: Improvements to pedestrian and bicycle facilities between Parkway Avenue and Canyon Creek Road.

EXISTING TRAFFIC VOLUMES

Historic turning movement count data was utilized for this traffic impact analysis that were previously collected prior to the Covid19 pandemic. The historic data was collected during weekday pm peak periods (4:00-6:00 pm). The intersections were collected on the below dates.

- Boeckman Road/ Parkway Avenue: May 22, 2019

³ Table 5-3/Figure 5-4, Wilsonville Transportation System Plan, Amended November 16, 2020.

- Boeckman Road/ Canyon Creek Road: May 22, 2019
- Boeckman Road/ Stafford Road/ Advance Road/ Wilsonville Road: May 22, 2019
- Stafford Road/ 65th Avenue: May 9, 2019

These historical counts were factored up to 2021 conditions by assuming a conservative yearly growth rate of 2%. This yearly growth rate is a typical growth rate used in Wilsonville traffic impact analyses and has been calculated using the Wilsonville Travel Demand model in previous studies.

Existing turning movements at the Frog Pond Lane/Stafford Road intersection were estimated using link volumes between the Boeckman Road/Stafford Road/Advance Road/Wilsonville Road and Stafford Road/ 65th Avenue intersections as well as Institute of Transportation Engineers (ITE) trip generation rates for Single-Family Detached Housing (210) for the existing houses along Frog Pond Lane.⁴

Figure 2 shows the 2021 Existing PM peak hour traffic volumes for the study intersections, along with the lane configurations and traffic control.

INTERSECTION PERFORMANCE MEASURES

Agency mobility standards often require intersections to meet level of service (LOS) or volume-to-capacity (v/c) intersection operation thresholds. Additional details about LOS and delay are provided in Appendix B.

- The intersection LOS is similar to a “report card” rating based upon average vehicle delay. Level of service A, B, and C indicate conditions where traffic moves without significant delays over periods of peak hour travel demand. Level of service D and E are progressively worse operating conditions. Level of service F represents conditions where average vehicle delay has become excessive and demand has exceeded capacity. This condition is typically evident in long queues and delays.
- The volume-to-capacity (v/c) ratio represents the level of saturation of the intersection or individual movement. It is determined by dividing the peak hour traffic volume by the maximum hourly capacity of an intersection or turn movement. When the V/C ratio approaches 0.95, operations become unstable and small disruptions can cause the traffic flow to break down, resulting in the formation of excessive queues.

The City of Wilsonville requires study intersections on public streets to meet its minimum acceptable level of service (LOS) standard of LOS D for the overall intersection for the PM peak period.⁵ For intersections under Clackamas County jurisdiction in the PM peak period in rural areas, signalized intersections must meet the volume-to-capacity ratio of 0.90 or less and unsignalized intersections must meet the minimum LOS standard of LOS E.⁶

⁴ Trip Generation Manual, 10th Edition, Institute of Transportation Engineers, 2017.

⁵ Policy 5, Wilsonville Transportation System Plan 2013, Amended November 16, 2020.

⁶ System Performance Policies, Chapter 5: Transportation System Plan, Clackamas County Comprehensive Plan, Amended January 18, 2017.

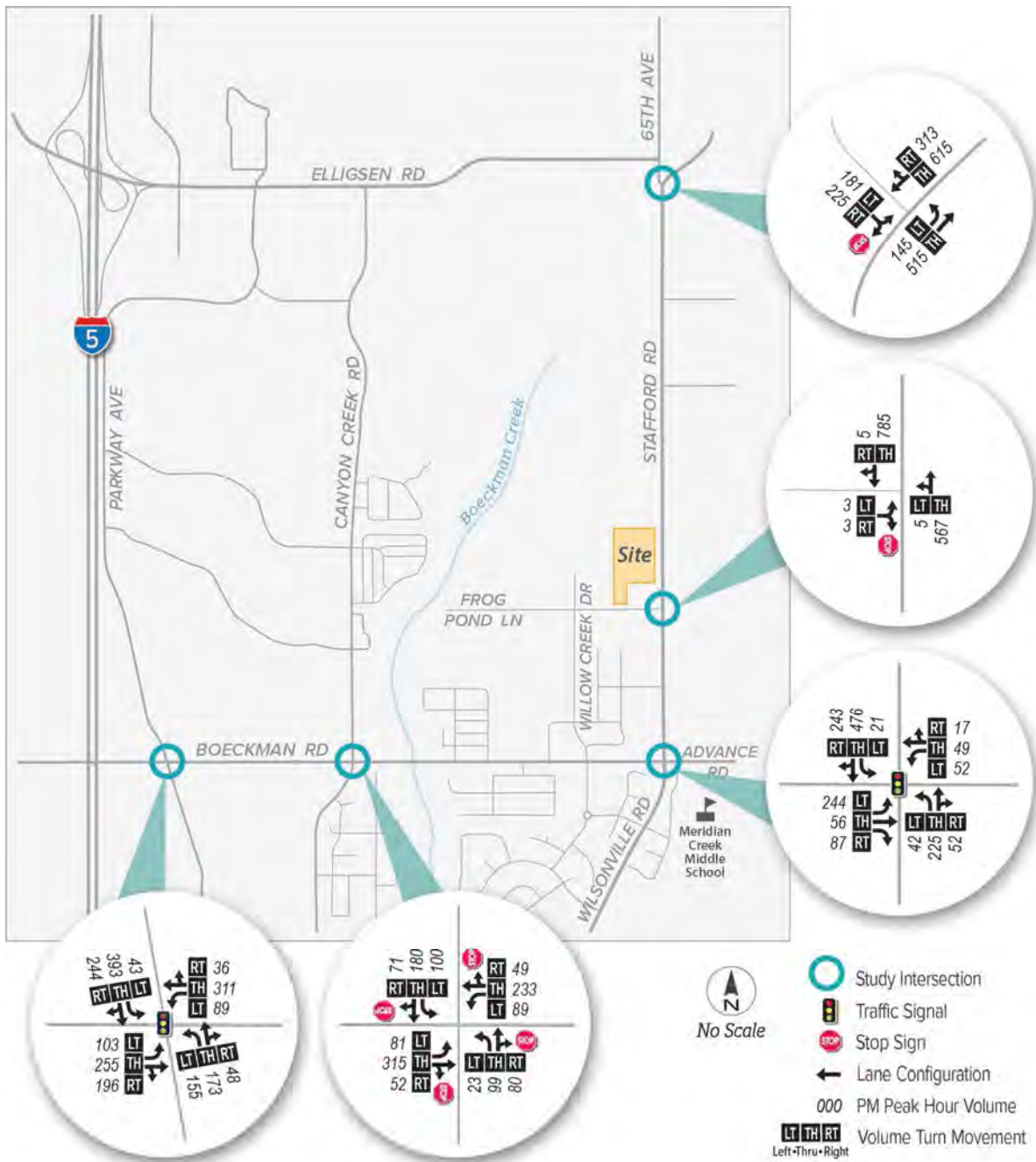

FIGURE 2: 2021 EXISTING PM TRAFFIC VOLUMES, LANE GEOMETRIES, AND TRAFFIC CONTROL

EXISTING INTERSECTION OPERATIONS

An analysis of the 2021 existing intersection operations was performed at the study intersections to determine the current operating conditions of the study area. Intersection operations were analyzed for the PM peak hour using Highway Capacity Manual (HCM) 6th Edition methodology.⁷ The volume to capacity (v/c) ratio, delay, and level of service (LOS) of each study intersection are listed in Table 3.

The Stafford Road/ 65th Avenue intersection is under Clackamas County jurisdiction, while all other intersections are under City of Wilsonville jurisdictions. While Frog Pond Lane is currently a Clackamas County road, the Frog Pond Lane/ Stafford Road intersection is within the City's Urban Growth Boundary (UGB) and will be incorporated into City limits once the development is constructed.

TABLE 3: EXISTING PM INTERSECTION OPERATIONS

INTERSECTION	OPERATING STANDARD	PM PEAK HOUR		
		V/C	DELAY	LOS
SIGNALIZED CONTROL				
BOECKMAN RD/ STAFFORD RD/ WILSONVILLE RD/ ADVANCE RD	LOS D	0.76	20.4	C
BOECKMAN RD/ PARKWAY AVENUE	LOS D	0.95	37.8	D
ALL-WAY STOP CONTROLLED				
BOECKMAN RD/ CANYON CREEK RD	LOS D	0.83	24.1	C
TWO-WAY STOP CONTROLLED				
STAFFORD RD/ 65 TH AVENUE	LOS E	>1.00	>120.0	B/F
STAFFORD RD/ FROG POND LANE	LOS D	0.03	22.5	A/C

SIGNALIZED INTERSECTION:

Delay = Average Intersection Delay (secs)
v/c = Total Volume-to-Capacity Ratio
LOS = Total Level of Service

ALL-WAY STOP CONTROLLED INTERSECTION:

Delay = Average Intersection Delay (secs)
v/c = Critical Movement Volume-to-Capacity Ratio
LOS = Total Level of Service

TWO-WAY STOP CONTROLLED INTERSECTION:

Delay = Critical Movement Delay (secs)
v/c = Critical Movement Volume-to-Capacity Ratio
LOS = Critical Levels of Service (Major/Minor Road)

Bold/Highlighted = Does not meet the operating standard/mobility target

As shown, the Stafford Rd/ 65th Avenue intersection fails to meet Clackamas County standards under existing conditions. All other intersections meet the City of Wilsonville's operating standards for the existing conditions.

⁷ Highway Capacity Manual, 6th Edition, Transportation Research Board, 2017.

PROJECT IMPACTS

This chapter reviews the impacts that the proposed development may have on the study area transportation system. This analysis includes site plan evaluation, trip generation, trip distribution, and future year traffic volumes and operating conditions for the five study intersections.

PROPOSED DEVELOPMENT

The proposed development includes 29 single-family home lots. The location of the proposed development is shown on all analysis figures and is part of the Frog Pond West Master Plan.⁸ The parcel is currently used primarily for agricultural purposes with one single-family home on it.

FUTURE ANALYSIS SCENARIOS

Operating conditions were analyzed at the study intersections for the following traffic scenarios. The comparison of the following scenarios enables the assessment of project impacts:

- Existing + Project
- Existing + Stage II
- Existing + Project + Stage II

All future analysis scenarios assume the same traffic control as existing conditions. Stage II represents traffic from other developments that have Stage II approval or are under construction in Wilsonville.

TRIP GENERATION

Trip generation is the method used to estimate the number of vehicles added to site driveways and the adjacent roadway network by a development during a specified period (i.e., such as the PM peak hour). For this study, the Institute of Transportation Engineers (ITE) trip generation rates for Single-Family Detached Housing (210) were used to estimate the site's trip generation, which is based on the number of housing lots in the development.⁹ As one home will be removed from the site during construction, the trips from that home have been subtracted from the total trips.

The trip generation for the proposed development is shown in Table 4. As shown, the proposed development is expected to generate a net total 31 PM peak hour trips (19 in, 12 out). The project trips at the study intersections are shown on Figure 3.

⁸ Frog Pond West Master Plan, City of Wilsonville, July 17, 2017.

⁹ Trip Generation Manual, 10th Edition, Institute of Transportation Engineers, 2017.

TABLE 4: VEHICLE TRIP GENERATION

LAND USE	ITE DESCRIPTION (CODE)	UNITS	PM PEAK TRIP RATE	PM PEAK TRIPS			WEEKDAY
				IN	OUT	TOTAL	
NEW HOMES	SINGLE-FAMILY DETACHED HOUSING (210)	29 Lots	1.07 trips per lot	20	11	31	334
EXISTING HOMES REMOVED	SINGLE-FAMILY DETACHED HOUSING (210)	1 Lot	1.00 trips per lot	-1	-0	-1	-15
Total Net New Trips				19	11	30	319

VEHICLE TRIP DISTRIBUTION

Vehicle trip distribution provides an estimation of where vehicles would be coming from and going to. It is given as a percentage at key gateways to the study area and is used to route project trips through the study intersections. Figure 3 shows the trip distribution for the proposed site. The trip distribution was based on the Wilsonville Travel Demand Model.

PROJECT TRIPS THROUGH CITY OF WILSONVILLE INTERCHANGE AREAS

The project trips through the two City of Wilsonville I-5 interchange areas were estimated based on the trip generation and distribution assumptions. Approximately 5% of the project trips are expected to travel through the I-5/Wilsonville Road interchange area and 5% are expected to travel through the I-5/Elligsen Road interchange area; that is, the proposed development is expected to generate 1 net new PM peak hour trips through the I-5/Wilsonville Road interchange area and 1 net new PM peak hour trips through the I-5/Elligsen Road interchange area.

FUTURE TRAFFIC VOLUMES

Traffic volumes were estimated at the study intersections for the three future analysis scenarios. The future scenarios include various combinations of three types of traffic: Existing, Project, and Stage II. Stage II development trips are estimated based on the list of currently approved Stage II developments provided by City staff.¹⁰ Figure 4, Figure 5, and Figure 6 show the PM peak hour traffic volumes for the following scenarios: Existing + Project, Existing + Stage II, Existing + Project + Stage II.

¹⁰ Email from Daniel Pauly, City of Wilsonville, July 8, 2021.

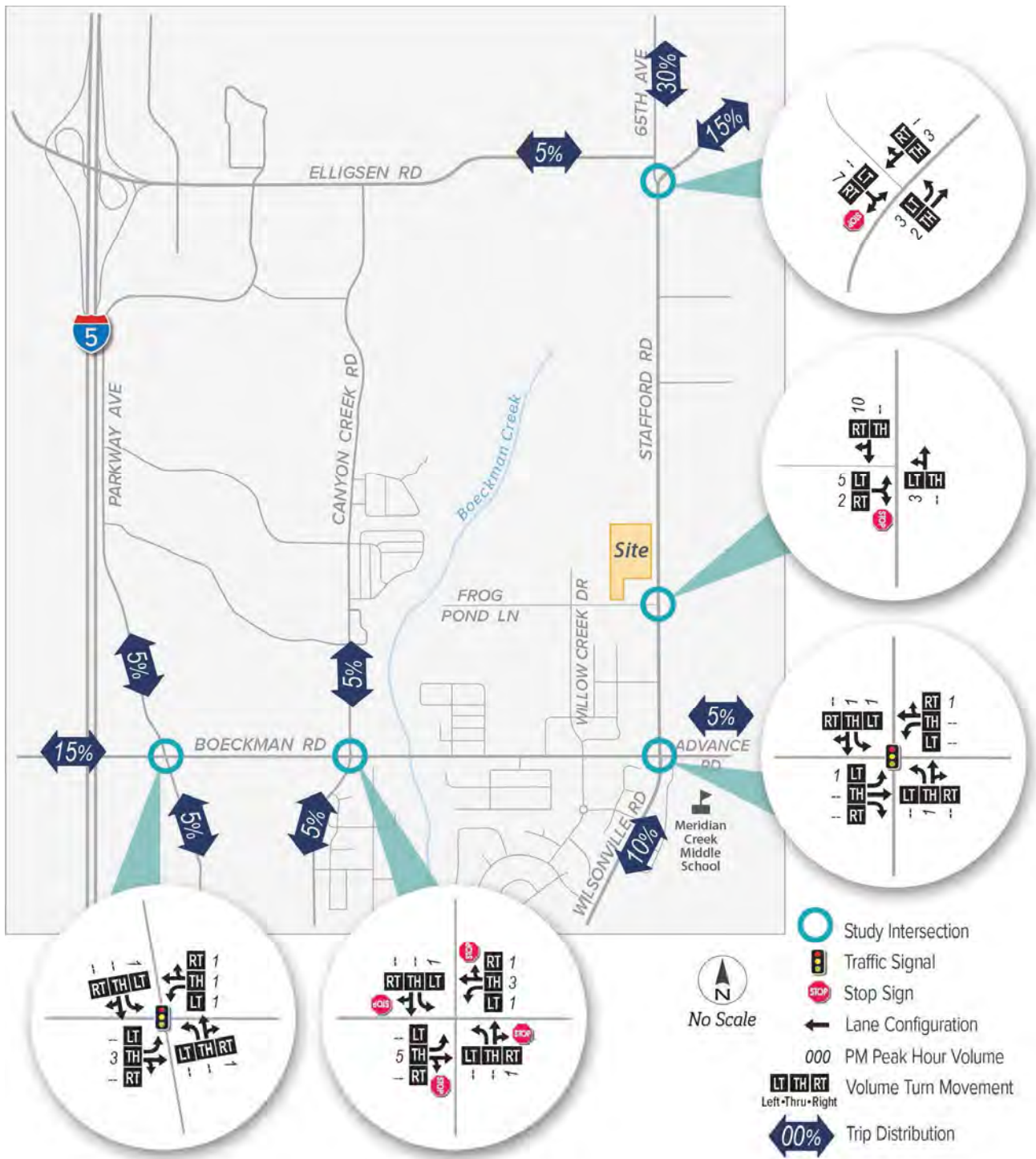

FIGURE 3: TRIP DISTRIBUTION AND PROJECT TRIPS

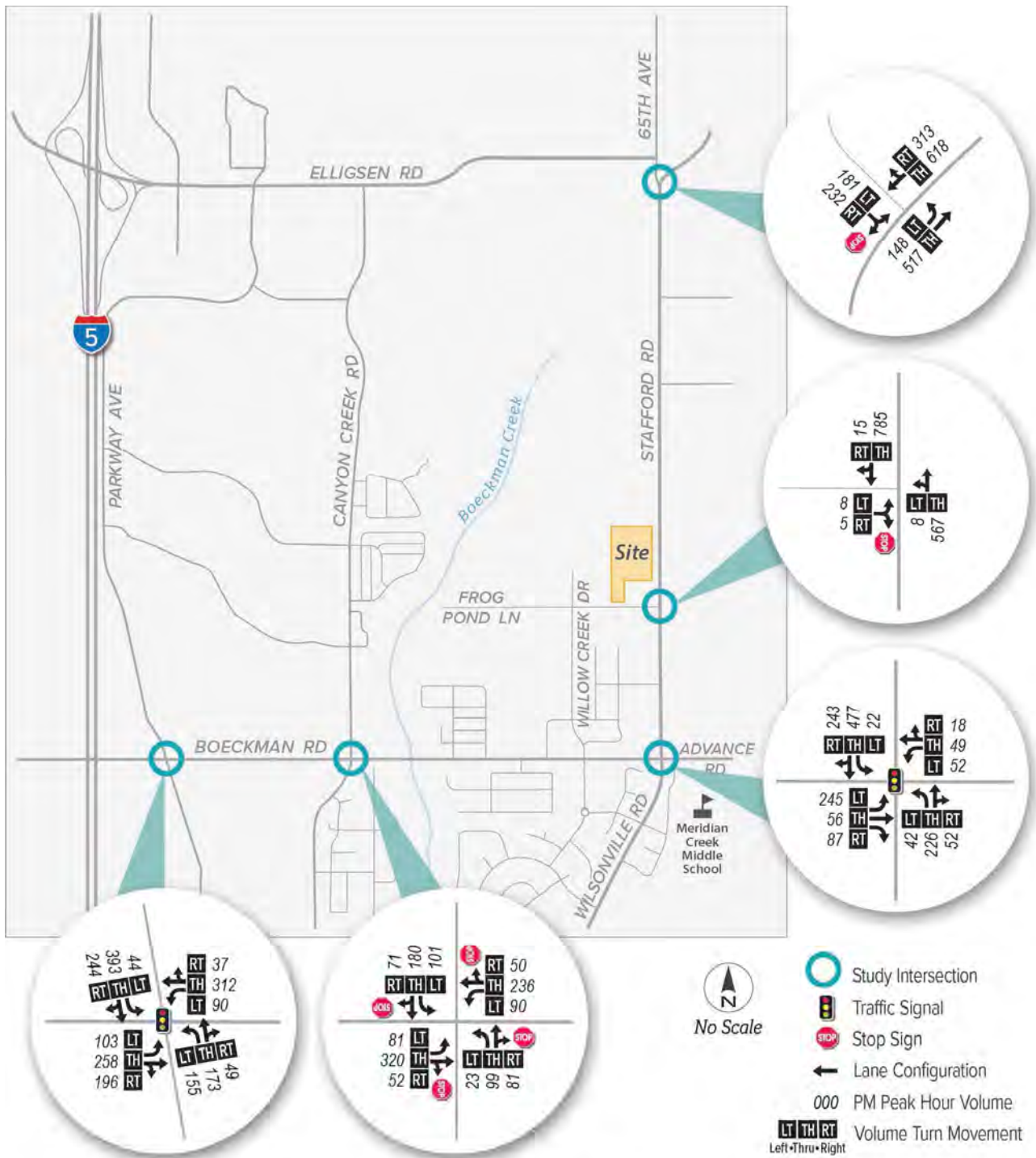

FIGURE 4: EXISTING PM + PROJECT PEAK HOUR TRAFFIC VOLUMES

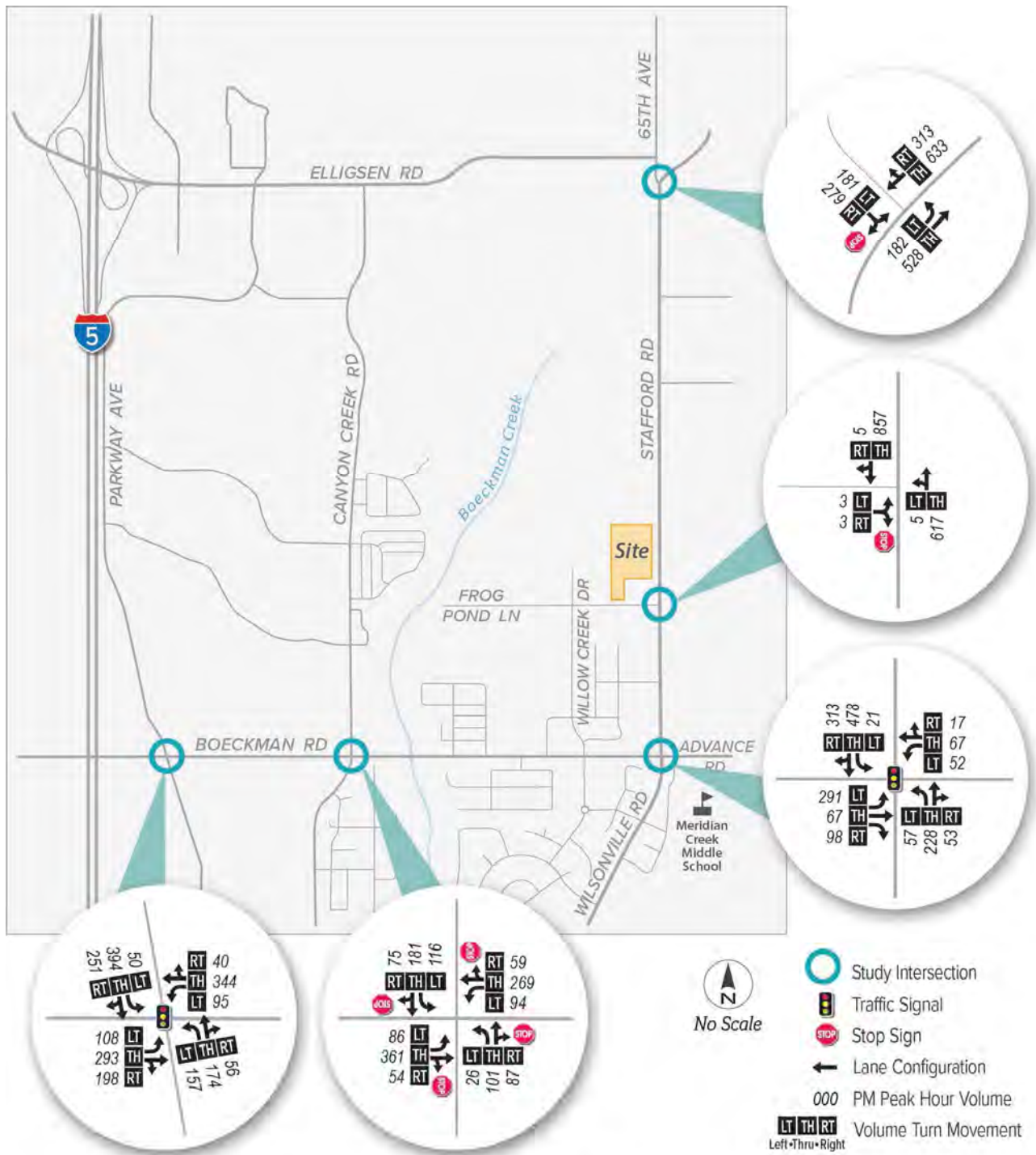

FIGURE 5: EXISTING PM + STAGE II PEAK HOUR TRAFFIC VOLUMES

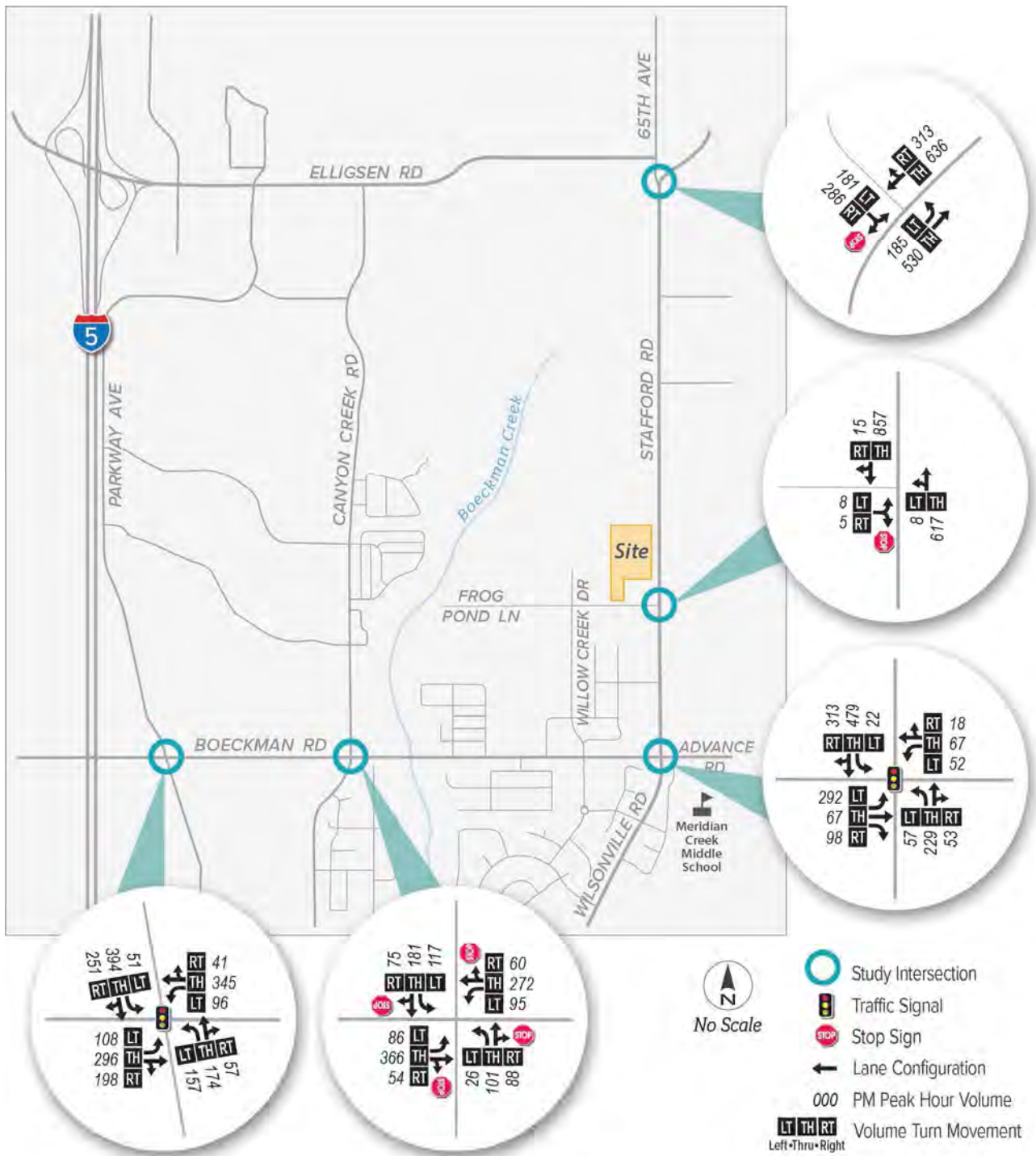

FIGURE 6: EXISTING PM + PROJECT + STAGE II PEAK HOUR TRAFFIC VOLUMES

FUTURE INTERSECTION OPERATIONS

Intersection operations were analyzed for the PM peak hour at all study intersections for the three future scenarios using Highway Capacity Manual (HCM) 6th Edition methodology.¹¹ The volume to capacity (v/c) ratio, delay, and level of service (LOS) of each study intersection are listed in Table 5.

TABLE 5: EXISTING PM, PROJECT, AND STAGE II INTERSECTION OPERATIONS

INTERSECTION	OPERATING STANDARD	EXISTING PM + PROJECT		EXISTING PM + STAGE II		EXISTING PM + PROJECT + STAGE II				
		V/C	DELAY	LOS	V/C	DELAY	LOS	V/C	DELAY	LOS
SIGNALIZED CONTROL										
BOECKMAN RD/ STAFFORD RD/ WILSONVILLE RD/ ADVANCE RD	LOS D	0.76	20.5	C	0.87	27.7	C	0.88	29.5	C
BOECKMAN RD/ PARKWAY AVE	LOS D	0.96	38.3	D	0.98	42.6	D	0.98	43.0	D
ALL-WAY STOP CONTROLLED										
BOECKMAN RD/ CANYON CREEK RD	LOS D	0.85	25.3	D	0.99	37.7	E	1.00	39.5	E
TWO-WAY STOP CONTROLLED										
STAFFORD RD/ 65 TH AVE	LOS E	>1.20	>120.0	B/F	>1.20	>120.0	B/F	>1.20	>120.0	B/F
STAFFORD RD/ FROG POND LN	LOS D	0.07	25.6	A/D	0.04	25.7	A/D	0.09	29.8	A/D

SIGNALIZED INTERSECTION:
 Delay = Average Intersection Delay (secs)
 V/C = Total Volume-to-Capacity Ratio
 LOS = Total Level of Service

ALL-WAY STOP CONTROLLED INTERSECTION:
 Delay = Average Intersection Delay (secs)
 V/C = Critical Movement Volume-to-Capacity Ratio
 LOS = Total Level of Service

TWO-WAY STOP CONTROLLED INTERSECTION:
 Delay = Critical Movement Delay (secs)
 V/C = Critical Movement Volume-to-Capacity Ratio
 LOS = Critical Levels of Service (Major/Minor Road)

Bold/Highlighted = Does not meet the operating standard/mobility target

¹¹ Highway Capacity Manual, 6th Edition, Transportation Research Board, 2017.

As shown, two of the five study intersections will fail to meet either County or City operating standards. Stafford Road/ 65th study intersection is expected to fail to meet Clackamas County standards under all future conditions. The Boeckman Road/ Canyon Creek Road intersection is expected to fail to meet City of Wilsonville standards under Existing PM + Stage II and Existing PM + Project + Stage II conditions, but not Existing PM + Project conditions. The recommended mitigation projects are discussed in the following section.

MITIGATION & FUNDING

The following sections contain the recommended mitigations for the two study intersections that were identified in the previous section to fail to meet jurisdictional operating standards.

Stafford Road/65th Avenue

The Stafford Road/ 65th Avenue intersection is under Clackamas County jurisdiction and currently fails to meet County operating standards under existing 2021 conditions.

In the Clackamas County 20-Year Capital Project List¹², a proposed future roundabout at the Stafford Road/65th Avenue/Elligsen Road intersection (Project ID 1079) is the recommended improvement. In the City of Wilsonville Transportation System Plan¹³, a traffic signal or roundabout has been identified as a High Priority Project (SI-03) at the same intersection. The City of Wilsonville's share cost of the project is 25% of the total project cost with the County funding the remaining portion. The developer's Transportation System Development Charge (SDC) will contribute to the City's share cost for the proposed intersection improvement.

Boeckman Road/ Canyon Creek Road

The Boeckman Road/ Canyon Creek Road operates at an overall LOS E in the following scenarios: *Existing + Stage II* and *Existing + Stage II + Project*. Therefore, mitigation measures must be explored to bring the operations back up to LOS D or better, in order to meet the City of Wilsonville standards.

The Wilsonville Transportation System Plan shows a traffic signal as a high priority project at the intersection of Boeckman Road/Canyon Creek Road as part of project UU-01.¹⁴ The developer's Transportation System Development Charge (SDC) will contribute to the City's fund to implement the traffic signal.

The construction of a new traffic signal at Boeckman Road/Canyon Creek Road will be coordinated with the other tasks in the project UU-01 Boeckman Road Dip Improvements, with construction estimated to begin in 2023.

¹² Clackamas County Comprehensive Plan, Table 5-3a, Amended January 18, 2017.

¹³ Wilsonville Transportation System Plan, Table 5-3, Amended November 16, 2020.

¹⁴ Wilsonville Transportation System Plan, Table 5-3, Amended November 16, 2020.

TABLE 6: INTERSECTION OPERATIONS – WITH MITIGATION

INTERSECTION	OPERATING STANDARD	EXISTING PM + PROJECT + STAGE II + MITIGATION		
		V/C	DELAY	LOS
SIGNALIZED CONTROL				
BOECKMAN RD/ CANYON CREEK RD	LOS D	0.63	17.8	B
ROUNDBABOUT				
STAFFORD RD/ 65 TH AVE / ELLIGSEN RD	LOS E	0.93	19.7	C
SIGNALIZED INTERSECTION: Delay = Average Intersection Delay (secs) v/c = Total Volume-to-Capacity Ratio LOS = Total Level of Service		ROUNDBABOUT: Delay = Average Intersection Delay (secs) v/c = Highest Approach Volume-to-Capacity Ratio LOS = Total Level of Service		

SITE REVIEW

This chapter reviews the provided site plan to determine consistency with the Frog Pond West Master Plan, including street configuration and zoning, and alignment with the Wilsonville Development Code or Construction Standards, including vehicular access, parking, circulation, and pedestrian and bicycle facilities.

FROG PONG WEST MASTER PLAN CONSISTENCY

The proposed street layout matches the framework plan as laid out in the Frog Pond West Master Plan.¹⁵ The residential zoning and land use in the site plan also appear to be consistent with the Master Plan. Five lots are zoned R5 (Small Lot Single Family) and the other 25 lots are zoned R7 (Medium Lot Single Family).

ACCESS SPACING

The proposed project is required to comply with access spacing requirements as laid out in the City Transportation System Plan.¹⁶ The access point for the new development on Frog Pond Lane will be approximately 500 ft west of the Frog Pond Lane/ Stafford Road intersection, satisfying the City's 300 ft desired spacing requirement for Collectors. There are no spacing requirements for local streets.

PARKING

The proposed project is required to comply with the City Development Code for the number of vehicular parking spots and bicycle parking spaces that are provided on site.¹⁷ For residential

¹⁵ Figure 16, Frog Pond West Master Plan, City of Wilsonville, July 17, 2017.

¹⁶ Table 3-2, Wilsonville Transportation System Plan, Amended November 2020.

¹⁷ Table 5, Section 4.155, Wilsonville Development Code, updated June 2020.

developments, one parking spot per dwelling unit is required. There is no minimum for bicycle parking. It is assumed that all home lots will have driveways that satisfy this vehicular parking requirement.

SITE CIRCULATION

The proposed project provides adequate site circulation when considering the entirety of the Frog Pond West Master Plan. The proposed site will have access to Stafford Road via Frog Pond Lane.

STREETS

The local streets within the subject property shall have on-street parking, sidewalks, and no dedicated bicycle facilities as shown in the Frog Pond West Master Plan.¹⁸

Frog Pond Lane will be a Gateway Collector with buffered bike lanes, sidewalks on both sides, and a landscaped median. The developer will be responsible for building these frontage improvements along the subject property frontage. Currently, Frog Pond Lane is a two-lane unimproved roadway.

Additionally, the Frog Pond Area Plan lists arterial urban upgrades to Stafford Road, including a northbound left turn lane at the Frog Pond Lane intersection. A combination of the Transportation System Development Charge and the Frog Pond Infrastructure Fee will be collected from the developer on cost per lot basis by the City to help fund the cost of the Stafford Road urban improvements, which will be built by the City.

¹⁸ Figure 22, Frog Pond West Master Plan, City of Wilsonville, July 17, 2017.

SUMMARY OF PROJECT IMPACTS

The key findings of the transportation impact study for the Frog Pond West Crossing development are discussed below.

- The project will consist of 29 single-family home lots as part of the Frog Pond West Master Plan. The parcel is currently used for agricultural purposes with one single-family home on it.
- The proposed development is expected to generate a net total of 30 PM peak hour trips (19 in, 11 out).
- Of the net project trips, approximately one (5%) trip is expected to travel through the I-5/Wilsonville Road interchange area and one (5%) trip is expected to travel through the I-5/Elligsen Road interchange area.
- Two study intersections are anticipated to fail to meet jurisdictional operating standards:
 - The Stafford Road/ 65th Avenue study intersection is expected to fail to meet Clackamas County standards (LOS E) under all future conditions.
 - The Boeckman Road/ Canyon Creek Road intersection is expected to fail to meet City of Wilsonville standards (LOS D) under Existing PM + Stage II and Existing PM + Project + Stage II conditions.
- The proposed mitigations at the study intersections are as follows. The developer's share cost of these improvements are covered by the Transportation SDC cost.
 - Stafford Road/ 65th Avenue: Install a roundabout or traffic signal (Clackamas County project).
 - Boeckman Road/ Canyon Creek Road: Install a traffic signal (City of Wilsonville project UU-01).
- The developer shall construct frontage improvements along the subject property frontage on Frog Pond Lane consistent with the Gateway Collector street standards provided in the Frog Pond Area Plan.
- The Stafford Road urban upgrades will be built by the City. The developer's cost share is covered by the Transportation SDCs and the Frog Pond Infrastructure Fee.
- Based on the provided site plan, it appears that the site will be consistent with the Frog Pond West Master Plan and meets applicable Wilsonville Development Codes and Construction Standards pertaining to vehicular access, parking, circulation, and pedestrian and bicycle facilities.

APPENDIX

CONTENTS

A. TRAFFIC COUNT DATA

B. HCM REPORTS – EXISTING

C. STAGE II LIST

D. HCM REPORTS – EXISTING + PROJECT

E. HCM REPORTS – EXISTING + STAGE II

F. HCM REPORTS – EXISTING + STAGE II + PROJECT

**G. HCM REPORTS – EXISTING + STAGE II + PROJECT +
MITIGATION**

H. SITE PLAN

A. TRAFFIC COUNT DATA



Data Provided by K-D-N.com 503-594-4224

N/S street	SW Parkway Ave
E/W street	SW Boeckman Rd
City, State	Wilsonville OR
Site Notes	
Location	45.317437 - -122.765886
Start Date	Wednesday, May 22, 2019
Start Time	04:00:00 PM
Weather	
Study ID #	
Peak Hour Start	04:55:00 PM
Peak 15 Min Start	05:05:00 PM
PHF (15-Min Int)	0.92

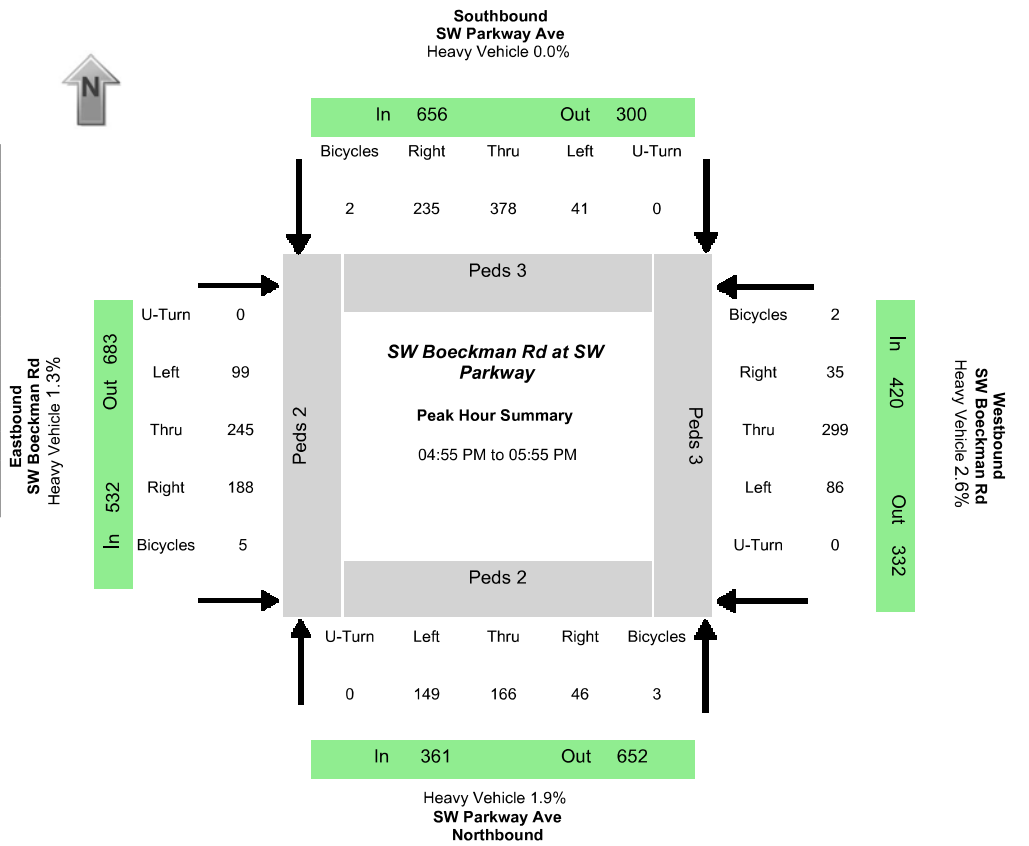

Peak-Hour Volumes (PHV)																							
Northbound				Southbound				Eastbound				Westbound				Entering				Leaving			
Left	Thru	Right	Uturn	Left	Thru	Right	Uturn	Left	Thru	Right	Uturn	Left	Thru	Right	Uturn	NB	SB	EB	WB	NB	SB	EB	WB
149	166	46	0	41	378	235	0	99	245	188	0	86	299	35	0	361	654	532	420	652	300	683	332
Percent Heavy Vehicles																							
0.7%	3.0%	2.2%	0.0%	0.0%	0.0%	0.0%	0.0%	3.0%	0.8%	1.1%	0.0%	2.3%	3.0%	0.0%	0.0%	1.9%	0.0%	1.3%	2.6%	0.6%	2.7%	1.5%	0.9%

PHV - Bicycles												PHV - Pedestrians									
Northbound				Southbound				Eastbound				Westbound				in Crosswalk					
Left	Thru	Right	Uturn	Left	Thru	Right	Uturn	Left	Thru	Right	Uturn	Left	Thru	Right	Uturn	Sum	NB	SB	EB	WB	Sum
0	0	3	0	0	0	2	0	0	4	1	0	0	2	0	0	12	2	3	2	3	10

Time	Northbound SW Parkway Ave				Southbound SW Parkway Ave				Eastbound SW Boeckman Rd				Westbound SW Boeckman Rd				15 Min Sum	1 HR Sum
	Left	Thru	Right	Uturn	Left	Thru	Right	Uturn	Left	Thru	Right	Uturn	Left	Thru	Right	Uturn		
04:00:00 PM	13	12	5	0	2	25	20	0	6	22	11	0	6	26	4	0		
04:05:00 PM	11	7	6	0	5	27	24	0	14	28	17	0	7	26	2	0		
04:10:00 PM	7	12	9	0	10	32	14	0	5	21	12	0	3	16	2	0	469	
04:15:00 PM	7	13	4	0	4	25	3	0	9	24	14	0	8	22	1	0	451	
04:20:00 PM	16	15	3	0	1	24	13	0	4	31	17	0	7	18	4	0	430	
04:25:00 PM	8	11	6	0	2	36	24	0	6	15	15	0	3	24	3	0	440	
04:30:00 PM	3	13	3	0	2	31	19	0	8	19	14	0	12	25	3	0	458	
04:35:00 PM	7	18	4	0	6	27	11	0	8	18	21	0	7	13	4	0	449	
04:40:00 PM	10	10	3	0	2	27	17	0	10	22	15	0	11	27	5	0	455	
04:45:00 PM	12	13	7	0	6	25	23	0	3	12	11	0	9	32	3	0	459	
04:50:00 PM	12	18	3	0	2	17	15	0	6	16	26	0	7	20	0	0	457	
04:55:00 PM	10	9	4	0	2	30	30	0	8	20	11	0	7	18	3	0	450	1814
05:00:00 PM	12	12	3	0	3	22	16	0	7	23	27	0	1	23	4	0	447	1815
05:05:00 PM	9	19	4	0	3	41	25	0	4	20	16	0	7	43	4	0	500	1836
05:10:00 PM	18	10	8	0	2	36	21	0	9	17	20	0	9	24	2	0	524	1869
05:15:00 PM	14	21	2	0	9	39	21	0	12	15	11	0	4	16	1	0	536	1900
05:20:00 PM	10	17	2	0	1	36	14	0	8	27	11	0	9	29	3	0	508	1914
05:25:00 PM	12	11	5	0	3	26	19	0	11	26	16	0	10	24	1	0	496	1925
05:30:00 PM	14	17	7	0	4	25	18	0	9	20	12	0	9	29	2	0	497	1939
05:35:00 PM	16	10	3	0	2	39	15	0	9	23	9	0	8	28	2	0	494	1959
05:40:00 PM	15	12	2	0	5	31	17	0	7	18	17	0	8	27	6	0	495	1965
05:45:00 PM	9	13	5	0	2	32	18	0	5	16	22	0	7	17	5	0	480	1960
05:50:00 PM	10	15	1	0	5	21	21	0	10	20	16	0	7	21	2	0	465	1967
05:55:00 PM	8	14	5	0	3	33	14	0	6	18	17	0	8	21	2	0	449	1964

Data Provided by K-D-N.com 503-594-4224

N/S street	SW Canyon Creek Rd
E/W street	SW Boeckman Rd
City, State	Wilsonville OR
Site Notes	
Location	45.317469 - -122.757745
Start Date	Wednesday, May 22, 2019
Start Time	04:00:00 PM
Weather	
Study ID #	
Peak Hour Start	04:40:00 PM
Peak 15 Min Start	04:55:00 PM
PHF (15-Min Int)	0.93

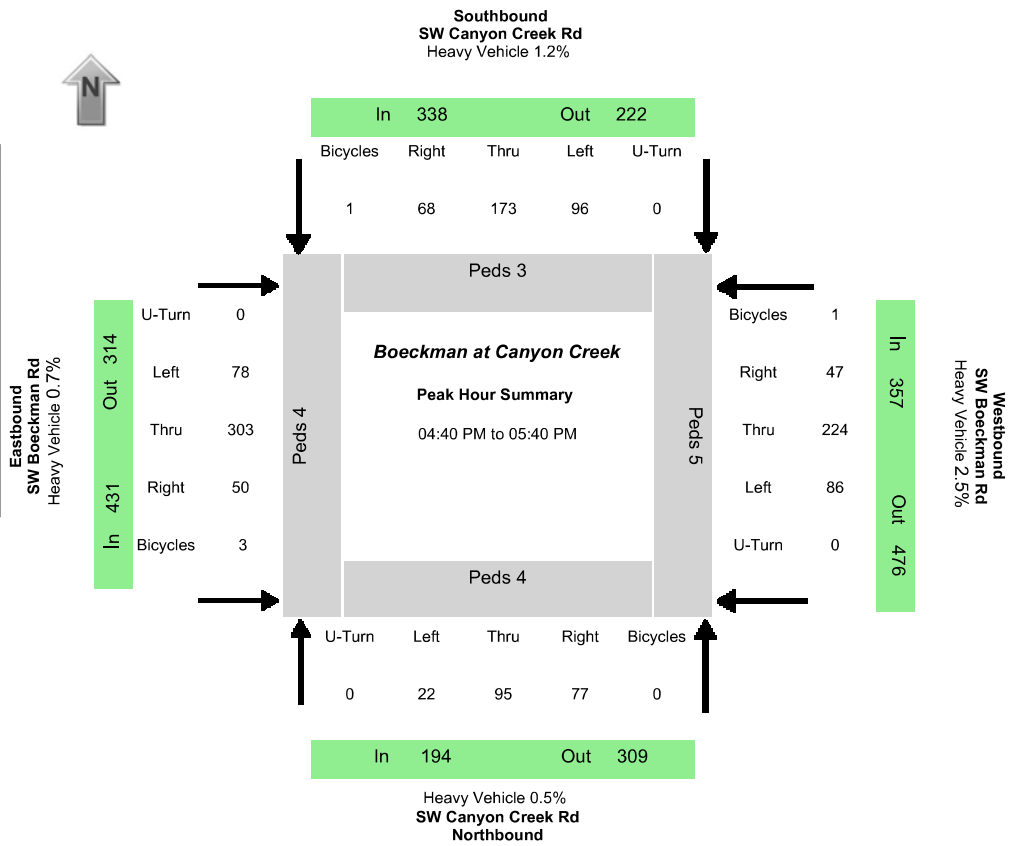

Peak-Hour Volumes (PHV)																							
Northbound				Southbound				Eastbound				Westbound				Entering				Leaving			
Left	Thru	Right	Uturn	Left	Thru	Right	Uturn	Left	Thru	Right	Uturn	Left	Thru	Right	Uturn	NB	SB	EB	WB	NB	SB	EB	WB
22	95	77	0	96	173	68	0	78	303	50	0	86	224	47	0	194	337	431	357	309	220	314	476
Percent Heavy Vehicles																							
0.0%	1.1%	0.0%	0.0%	1.0%	1.2%	1.5%	0.0%	1.3%	0.7%	0.0%	0.0%	2.3%	2.2%	4.3%	0.0%	0.5%	1.2%	0.7%	2.5%	1.3%	1.8%	1.9%	0.6%

PHV - Bicycles														PHV - Pedestrians							
Northbound				Southbound				Eastbound				Westbound				in Crosswalk					
Left	Thru	Right	Uturn	Left	Thru	Right	Uturn	Left	Thru	Right	Uturn	Left	Thru	Right	Uturn	Sum	NB	SB	EB	WB	Sum
0	0	0	0	0	1	0	0	1	2	0	0	0	0	1	0	5	4	3	4	5	16

Time	Northbound SW Canyon Creek Rd				Southbound SW Canyon Creek Rd				Eastbound SW Boeckman Rd				Westbound SW Boeckman Rd				15 Min Sum	1 HR Sum
	Left	Thru	Right	Uturn	Left	Thru	Right	Uturn	Left	Thru	Right	Uturn	Left	Thru	Right	Uturn		
04:00:00 PM	2	8	5	0	8	10	2	0	3	17	1	0	8	17	7	0		
04:05:00 PM	5	4	7	0	8	10	1	0	5	38	6	0	3	19	4	0		
04:10:00 PM	1	10	7	0	10	13	4	0	9	33	4	0	6	13	6	0	314	
04:15:00 PM	0	10	4	0	13	13	8	0	3	21	7	0	8	17	7	0	337	
04:20:00 PM	2	5	3	0	5	10	11	0	5	27	6	0	3	14	4	0	322	
04:25:00 PM	2	9	4	0	5	15	3	0	6	31	3	0	4	17	3	0	308	
04:30:00 PM	1	9	10	0	4	14	4	0	6	19	2	0	5	20	2	0	293	
04:35:00 PM	1	6	10	0	10	9	3	0	10	28	2	0	6	15	2	0	300	
04:40:00 PM	3	15	5	0	10	7	3	0	7	24	4	0	10	20	1	0	307	
04:45:00 PM	3	8	2	0	5	7	7	0	5	23	3	0	5	22	5	0	306	
04:50:00 PM	2	5	10	0	5	17	3	0	8	21	2	0	11	16	3	0	307	
04:55:00 PM	2	6	7	0	17	20	7	0	9	23	3	0	6	16	7	0	321	1250
05:00:00 PM	3	13	5	0	8	16	6	0	5	26	4	0	8	22	3	0	345	1281
05:05:00 PM	3	7	5	0	5	18	8	0	12	21	6	0	3	18	5	0	353	1282
05:10:00 PM	1	6	10	0	8	17	5	0	6	25	2	0	5	16	4	0	335	1271
05:15:00 PM	3	6	8	0	12	14	6	0	4	31	7	0	7	13	4	0	331	1275
05:20:00 PM	1	7	6	0	3	18	8	0	5	23	7	0	9	22	2	0	331	1291
05:25:00 PM	1	8	4	0	6	13	5	0	6	32	3	0	9	20	6	0	339	1302
05:30:00 PM	0	8	7	0	7	13	5	0	5	29	5	0	6	17	3	0	329	1311
05:35:00 PM	0	6	8	0	10	13	5	0	6	25	4	0	7	22	4	0	328	1319
05:40:00 PM	1	7	4	0	12	7	5	0	8	23	2	0	7	16	1	0	308	1303
05:45:00 PM	1	8	3	0	8	17	5	0	5	23	5	0	9	16	3	0	306	1311
05:50:00 PM	0	10	7	0	19	9	5	0	2	25	4	0	7	19	2	0	305	1317
05:55:00 PM	4	7	3	0	5	15	4	0	6	20	6	0	16	22	3	0	323	1305

Data Provided by K-D-N.com 503-594-4224

N/S street	SW Wilsonville Rd
E/W street	SW Boeckman Rd
City, State	Wilsonville OR
Site Notes	
Location	45.317521 - -122.743751
Start Date	Wednesday, May 22, 2019
Start Time	04:00:00 PM
Weather	
Study ID #	
Peak Hour Start	04:40:00 PM
Peak 15 Min Start	05:25:00 PM
PHF (15-Min Int)	0.95

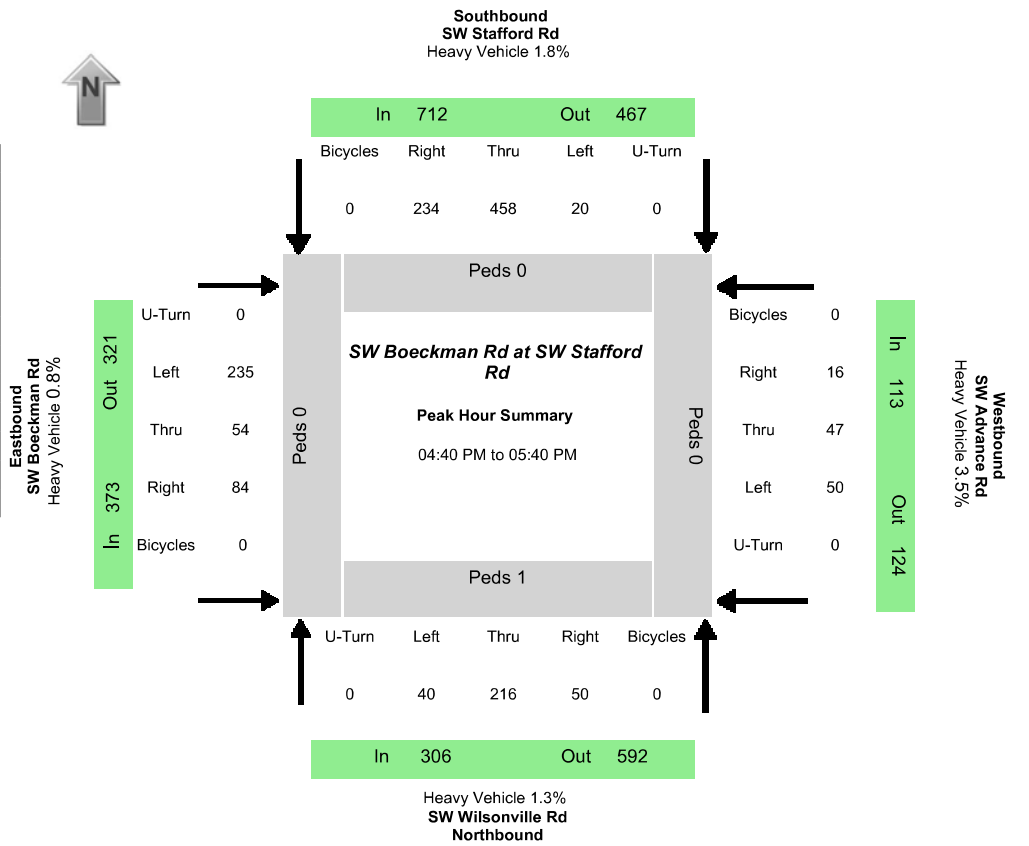

Peak-Hour Volumes (PHV)																							
Northbound				Southbound				Eastbound				Westbound				Entering				Leaving			
Left	Thru	Right	Uturn	Left	Thru	Right	Uturn	Left	Thru	Right	Uturn	Left	Thru	Right	Uturn	NB	SB	EB	WB	NB	SB	EB	WB
40	216	50	0	20	458	234	0	235	54	84	0	50	47	16	0	306	712	373	113	592	467	321	124
Percent Heavy Vehicles																							
2.5%	0.5%	4.0%	0.0%	10.0%	0.4%	3.8%	0.0%	0.9%	1.9%	0.0%	0.0%	6.0%	2.1%	0.0%	0.0%	1.3%	1.8%	0.8%	3.5%	0.8%	0.6%	3.4%	4.0%

PHV- Bicycles														PHV - Pedestrians							
Northbound				Southbound				Eastbound				Westbound				in Crosswalk					
Left	Thru	Right	Uturn	Left	Thru	Right	Uturn	Left	Thru	Right	Uturn	Left	Thru	Right	Uturn	Sum	NB	SB	EB	WB	Sum
0	0	0	0	0	0	0	0	0	0	0	0	0	0	0	0	0	1	0	0	0	1

Time	Northbound SW Wilsonville Rd				Southbound SW Stafford Rd				Eastbound SW Boeckman Rd				Westbound SW Advance Rd				15 Min Sum	1 HR Sum
	Left	Thru	Right	Uturn	Left	Thru	Right	Uturn	Left	Thru	Right	Uturn	Left	Thru	Right	Uturn		
04:00:00 PM	6	14	7	0	3	23	22	0	16	4	2	0	2	2	2	0		
04:05:00 PM	3	12	3	0	0	22	11	0	34	5	9	0	6	7	6	0		
04:10:00 PM	3	15	5	0	2	27	13	0	32	5	9	0	4	6	4	0	346	
04:15:00 PM	8	15	3	0	2	30	15	0	23	6	5	0	8	3	0	0	361	
04:20:00 PM	6	18	5	0	2	23	8	0	17	5	6	0	3	3	4	0	343	
04:25:00 PM	4	13	3	0	0	39	12	0	25	9	8	0	5	1	0	0	337	
04:30:00 PM	7	27	1	0	0	31	13	0	14	5	3	0	3	5	2	0	330	
04:35:00 PM	6	14	2	0	1	35	18	0	32	5	8	0	5	4	2	0	362	
04:40:00 PM	2	25	4	0	5	46	18	0	21	4	12	0	3	3	0	0	386	
04:45:00 PM	3	21	5	0	0	27	17	0	17	2	6	0	8	9	3	0	393	
04:50:00 PM	1	15	1	0	1	45	13	0	15	6	4	0	7	9	0	0	378	
04:55:00 PM	2	20	6	0	3	41	17	0	13	2	9	0	3	2	2	0	355	1424
05:00:00 PM	8	17	1	0	2	40	25	0	26	7	9	0	4	1	1	0	378	1462
05:05:00 PM	4	26	2	0	2	31	16	0	15	5	3	0	6	3	0	0	374	1457
05:10:00 PM	3	12	7	0	1	30	12	0	29	8	3	0	3	3	2	0	367	1445
05:15:00 PM	2	17	3	0	2	38	15	0	26	0	9	0	4	3	3	0	348	1449
05:20:00 PM	5	10	6	0	1	34	30	0	17	4	6	0	2	3	3	0	356	1470
05:25:00 PM	4	15	8	0	1	36	21	0	24	6	9	0	1	4	0	0	372	1480
05:30:00 PM	5	18	4	0	2	45	16	0	16	8	8	0	4	6	0	0	382	1501
05:35:00 PM	1	20	3	0	0	45	34	0	16	2	6	0	5	1	2	0	396	1504
05:40:00 PM	1	14	2	0	0	35	12	0	18	6	9	0	3	1	0	0	368	1462
05:45:00 PM	5	18	2	0	4	40	25	0	21	3	6	0	7	1	1	0	369	1477
05:50:00 PM	4	10	2	0	0	18	14	0	15	7	9	0	2	1	0	0	316	1442
05:55:00 PM	7	12	2	0	1	28	21	0	13	4	7	0	1	2	1	0	314	1421



KEY DATA NETWORK

Data Provided by K-D-N.com 503-594-4224	
N/S street	65th Ave
E/W street	Stafford Rd
City, State	Wilsonville OR
Site Notes	
Location	45.335919 - -122.74347
Start Date	Thursday, May 09, 2019
Start Time	04:00:00 PM
Weather	
Study ID #	
Peak Hour Start	04:15:00 PM
Peak 15 Min Start	05:00:00 PM
PHF (15-Min Int)	0.84

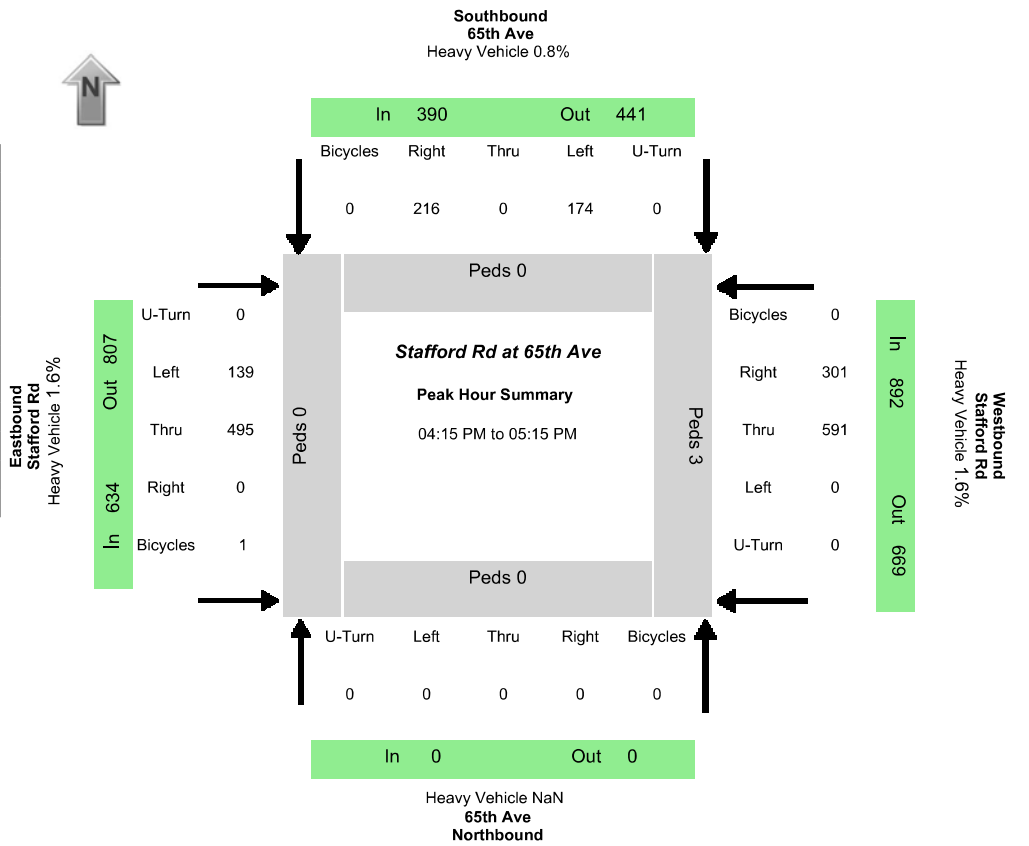

Peak-Hour Volumes (PHV)																							
Northbound				Southbound				Eastbound				Westbound				Entering				Leaving			
Left	Thru	Right	Uturn	Left	Thru	Right	Uturn	Left	Thru	Right	Uturn	Left	Thru	Right	Uturn	NB	SB	EB	WB	NB	SB	EB	WB
0	0	0	0	174	0	216	0	139	495	0	0	0	591	301	0	0	390	634	892	0	440	807	669
Percent Heavy Vehicles																							
0.0%	0.0%	0.0%	0.0%	1.1%	0.0%	0.5%	0.0%	4.3%	0.8%	0.0%	0.0%	0.0%	1.0%	2.7%	0.0%	NaN	0.8%	1.6%	1.6%	NaN	3.2%	0.9%	0.9%

PHV - Bicycles														PHV - Pedestrians							
Northbound				Southbound				Eastbound				Westbound				in Crosswalk					
Left	Thru	Right	Uturn	Left	Thru	Right	Uturn	Left	Thru	Right	Uturn	Left	Thru	Right	Uturn	Sum	NB	SB	EB	WB	Sum
0	0	0	0	0	0	0	0	1	0	0	0	0	0	0	0	1	0	0	0	3	3





















All Vehicle Volumes																		
Time	Northbound 65th Ave				Southbound 65th Ave				Eastbound Stafford Rd				Westbound Stafford Rd				15 Min Sum	1 HR Sum
	Left	Thru	Right	Uturn	Left	Thru	Right	Uturn	Left	Thru	Right	Uturn	Left	Thru	Right	Uturn		
04:00:00 PM	0	0	0	0	24	0	23	0	5	29	0	0	0	25	20	0		
04:05:00 PM	0	0	0	0	12	0	16	0	10	33	0	0	0	49	19	0		
04:10:00 PM	0	0	0	0	14	0	15	0	11	28	0	0	0	34	21	0	388	
04:15:00 PM	0	0	0	0	19	0	23	0	8	40	0	0	0	35	20	0	407	
04:20:00 PM	0	0	0	0	8	0	10	0	14	32	0	0	0	43	14	0	389	
04:25:00 PM	0	0	0	0	15	0	19	0	12	41	0	0	0	49	22	0	424	
04:30:00 PM	0	0	0	0	19	0	19	0	6	46	0	0	0	50	24	0	443	
04:35:00 PM	0	0	0	0	9	0	12	0	9	36	0	0	0	39	27	0	454	
04:40:00 PM	0	0	0	0	14	0	19	0	10	31	0	0	0	35	27	0	432	
04:45:00 PM	0	0	0	0	10	0	15	0	11	33	0	0	0	54	25	0	416	
04:50:00 PM	0	0	0	0	13	0	19	0	10	33	0	0	0	50	31	0	440	
04:55:00 PM	0	0	0	0	9	0	14	0	16	53	0	0	0	63	31	0	490	1734
05:00:00 PM	0	0	0	0	14	0	20	0	12	32	0	0	0	34	23	0	477	1743
05:05:00 PM	0	0	0	0	15	0	15	0	10	37	0	0	0	42	20	0	460	1743
05:10:00 PM	0	0	0	0	29	0	31	0	21	81	0	0	0	97	37	0	570	1916
05:15:00 PM	0	0	0	0	0	0	0	0	0	0	0	0	0	0	0	0	435	1771
05:20:00 PM	0	0	0	0	9	0	11	0	12	38	0	0	0	60	20	0	446	1800
05:25:00 PM	0	0	0	0	11	0	21	0	8	35	0	0	0	56	21	0	302	1794
05:30:00 PM	0	0	0	0	14	0	23	0	11	30	0	0	0	32	20	0	432	1760
05:35:00 PM	0	0	0	0	17	0	17	0	6	37	0	0	0	46	15	0	420	1766
05:40:00 PM	0	0	0	0	11	0	29	0	17	34	0	0	0	38	24	0	421	1783
05:45:00 PM	0	0	0	0	16	0	10	0	11	33	0	0	0	36	19	0	416	1760
05:50:00 PM	0	0	0	0	11	0	21	0	8	28	0	0	0	29	12	0	387	1713
05:55:00 PM	0	0	0	0	14	0	25	0	9	27	0	0	0	21	18	0	348	1641

B. HCM REPORTS – EXISTING



HCM 6th Signalized Intersection Summary
1: Parkway Ave & Boeckman Rd

Frog Pond Crossing
Existing PM

												
Movement	EBL	EBT	EBR	WBL	WBT	WBR	NBL	NBT	NBR	SBL	SBT	SBR
Lane Configurations												
Traffic Volume (veh/h)	103	255	196	89	311	36	155	173	48	43	393	244
Future Volume (veh/h)	103	255	196	89	311	36	155	173	48	43	393	244
Initial Q (Qb), veh	0	0	0	0	0	0	0	0	0	0	0	0
Ped-Bike Adj(A_pbT)	1.00		0.97	1.00		0.97	1.00		0.97	1.00		0.97
Parking Bus, Adj	1.00	1.00	1.00	1.00	1.00	1.00	1.00	1.00	1.00	1.00	1.00	1.00
Work Zone On Approach		No			No			No			No	
Adj Sat Flow, veh/h/ln	1930	1885	1885	1870	1856	1900	1885	1856	1870	1976	1976	1900
Adj Flow Rate, veh/h	112	277	179	97	338	35	168	188	41	47	427	239
Peak Hour Factor	0.92	0.92	0.92	0.92	0.92	0.92	0.92	0.92	0.92	0.92	0.92	0.92
Percent Heavy Veh, %	3	1	1	2	3	0	1	3	2	0	0	0
Cap, veh/h	290	295	191	208	451	47	250	631	138	565	454	254
Arrive On Green	0.06	0.28	0.28	0.06	0.27	0.27	0.08	0.43	0.43	0.03	0.39	0.39
Sat Flow, veh/h	1838	1055	681	1781	1648	171	1795	1468	320	1882	1178	659
Grp Volume(v), veh/h	112	0	456	97	0	373	168	0	229	47	0	666
Grp Sat Flow(s),veh/h/ln	1838	0	1736	1781	0	1819	1795	0	1788	1882	0	1837
Q Serve(g_s), s	3.6	0.0	21.6	3.2	0.0	15.7	4.5	0.0	7.0	1.3	0.0	29.4
Cycle Q Clear(g_c), s	3.6	0.0	21.6	3.2	0.0	15.7	4.5	0.0	7.0	1.3	0.0	29.4
Prop In Lane	1.00		0.39	1.00		0.09	1.00		0.18	1.00		0.36
Lane Grp Cap(c), veh/h	290	0	486	208	0	498	250	0	769	565	0	707
V/C Ratio(X)	0.39	0.00	0.94	0.47	0.00	0.75	0.67	0.00	0.30	0.08	0.00	0.94
Avail Cap(c_a), veh/h	350	0	486	277	0	509	284	0	769	685	0	732
HCM Platoon Ratio	1.00	1.00	1.00	1.00	1.00	1.00	1.00	1.00	1.00	1.00	1.00	1.00
Upstream Filter(I)	1.00	0.00	1.00	1.00	0.00	1.00	1.00	0.00	1.00	1.00	0.00	1.00
Uniform Delay (d), s/veh	21.4	0.0	29.6	22.9	0.0	27.9	19.1	0.0	15.7	14.7	0.0	24.9
Incr Delay (d2), s/veh	0.8	0.0	26.4	1.6	0.0	6.0	5.1	0.0	0.2	0.1	0.0	20.0
Initial Q Delay(d3),s/veh	0.0	0.0	0.0	0.0	0.0	0.0	0.0	0.0	0.0	0.0	0.0	0.0
%ile BackOfQ(50%),veh/ln	1.6	0.0	12.2	1.4	0.0	7.4	2.0	0.0	2.8	0.5	0.0	15.9
Unsig. Movement Delay, s/veh												
LnGrp Delay(d),s/veh	22.2	0.0	55.9	24.5	0.0	33.9	24.2	0.0	15.9	14.8	0.0	44.9
LnGrp LOS	C	A	E	C	A	C	C	A	B	B	A	D
Approach Vol, veh/h		568			470			397			713	
Approach Delay, s/veh		49.3			31.9			19.4			42.9	
Approach LOS		D			C			B			D	
Timer - Assigned Phs	1	2	3	4	5	6	7	8				
Phs Duration (G+Y+Rc), s	10.4	36.9	8.7	28.0	6.7	40.6	9.3	27.5				
Change Period (Y+Rc), s	4.0	4.5	4.0	4.5	4.0	4.5	4.0	4.5				
Max Green Setting (Gmax), s	8.0	33.5	8.0	23.5	8.0	33.5	8.0	23.5				
Max Q Clear Time (g_c+I1), s	6.5	31.4	5.2	23.6	3.3	9.0	5.6	17.7				
Green Ext Time (p_c), s	0.1	1.0	0.0	0.0	0.0	1.3	0.1	1.1				
Intersection Summary												
HCM 6th Ctrl Delay			37.8									
HCM 6th LOS			D									

Intersection

Intersection Delay, s/veh24.1
Intersection LOS C

Movement	EBL	EBT	EBR	WBL	WBT	WBR	NBL	NBT	NBR	SBL	SBT	SBR
Lane Configurations												
Traffic Vol, veh/h	81	315	52	89	233	49	23	99	80	100	180	71
Future Vol, veh/h	81	315	52	89	233	49	23	99	80	100	180	71
Peak Hour Factor	0.93	0.93	0.93	0.93	0.93	0.93	0.93	0.93	0.93	0.93	0.93	0.93
Heavy Vehicles, %	1	1	0	2	2	4	0	1	0	1	1	1
Mvmt Flow	87	339	56	96	251	53	25	106	86	108	194	76
Number of Lanes	1	1	0	1	1	0	1	1	0	1	1	0

Approach	EB	WB	NB	SB
Opposing Approach	WB	EB	SB	NB
Opposing Lanes	2	2	2	2
Conflicting Approach Left SB		NB	EB	WB
Conflicting Lanes Left	2	2	2	2
Conflicting Approach Right NB		SB	WB	EB
Conflicting Lanes Right	2	2	2	2
HCM Control Delay	32.9	21.8	16.7	19.6
HCM LOS	D	C	C	C

Lane	NBLn1	NBLn2	EBLn1	EBLn2	WBLn1	WBLn2	SBLn1	SBLn2
Vol Left, %	100%	0%	100%	0%	100%	0%	100%	0%
Vol Thru, %	0%	55%	0%	86%	0%	83%	0%	72%
Vol Right, %	0%	45%	0%	14%	0%	17%	0%	28%
Sign Control	Stop	Stop	Stop	Stop	Stop	Stop	Stop	Stop
Traffic Vol by Lane	23	179	81	367	89	282	100	251
LT Vol	23	0	81	0	89	0	100	0
Through Vol	0	99	0	315	0	233	0	180
RT Vol	0	80	0	52	0	49	0	71
Lane Flow Rate	25	192	87	395	96	303	108	270
Geometry Grp	7	7	7	7	7	7	7	7
Degree of Util (X)	0.062	0.44	0.199	0.825	0.225	0.658	0.259	0.595
Departure Headway (Hd)	9.051	8.225	8.245	7.658	8.457	7.815	8.655	7.933
Convergence, Y/N	Yes	Yes	Yes	Yes	Yes	Yes	Yes	Yes
Cap	397	439	436	477	426	464	417	456
Service Time	6.784	5.957	5.975	5.358	6.176	5.534	6.371	5.649
HCM Lane V/C Ratio	0.063	0.437	0.2	0.828	0.225	0.653	0.259	0.592
HCM Control Delay	12.4	17.3	13	37.3	13.6	24.4	14.4	21.7
HCM Lane LOS	B	C	B	E	B	C	B	C
HCM 95th-tile Q	0.2	2.2	0.7	8	0.9	4.7	1	3.8

HCM 6th Signalized Intersection Summary
 3: Wilsonville Rd/Stafford Rd & Boeckman Rd/Advance Rd

Frog Pond Crossing
 Existing PM



Movement	EBL	EBT	EBR	WBL	WBT	WBR	NBL	NBT	NBR	SBL	SBT	SBR
Lane Configurations												
Traffic Volume (veh/h)	244	56	87	52	49	17	42	225	52	21	476	243
Future Volume (veh/h)	244	56	87	52	49	17	42	225	52	21	476	243
Initial Q (Qb), veh	0	0	0	0	0	0	0	0	0	0	0	0
Ped-Bike Adj(A_pbT)	1.00		1.00	0.99		0.99	1.00		1.00	1.00		1.00
Parking Bus, Adj	1.00	1.00	1.00	1.00	1.00	1.00	1.00	1.00	1.00	1.00	1.00	1.00
Work Zone On Approach		No			No			No			No	
Adj Sat Flow, veh/h/ln	1885	1870	1900	1811	1870	1900	1870	1900	1841	1752	1900	1841
Adj Flow Rate, veh/h	257	59	17	55	52	2	44	237	47	22	501	237
Peak Hour Factor	0.95	0.95	0.95	0.95	0.95	0.95	0.95	0.95	0.95	0.95	0.95	0.95
Percent Heavy Veh, %	1	2	0	6	2	0	2	0	4	10	0	4
Cap, veh/h	440	336	289	255	107	4	242	742	147	543	571	270
Arrive On Green	0.16	0.18	0.18	0.04	0.06	0.06	0.03	0.48	0.48	0.02	0.47	0.47
Sat Flow, veh/h	1795	1870	1606	1725	1789	69	1781	1540	305	1668	1219	577
Grp Volume(v), veh/h	257	59	17	55	0	54	44	0	284	22	0	738
Grp Sat Flow(s),veh/h/ln	1795	1870	1606	1725	0	1857	1781	0	1845	1668	0	1796
Q Serve(g_s), s	8.1	1.7	0.6	1.9	0.0	1.8	0.8	0.0	6.1	0.4	0.0	23.9
Cycle Q Clear(g_c), s	8.1	1.7	0.6	1.9	0.0	1.8	0.8	0.0	6.1	0.4	0.0	23.9
Prop In Lane	1.00		1.00	1.00		0.04	1.00		0.17	1.00		0.32
Lane Grp Cap(c), veh/h	440	336	289	255	0	111	242	0	889	543	0	841
V/C Ratio(X)	0.58	0.18	0.06	0.22	0.00	0.49	0.18	0.00	0.32	0.04	0.00	0.88
Avail Cap(c_a), veh/h	537	755	648	298	0	473	295	0	1083	615	0	1054
HCM Platoon Ratio	1.00	1.00	1.00	1.00	1.00	1.00	1.00	1.00	1.00	1.00	1.00	1.00
Upstream Filter(I)	1.00	1.00	1.00	1.00	0.00	1.00	1.00	0.00	1.00	1.00	0.00	1.00
Uniform Delay (d), s/veh	21.3	22.4	21.9	27.0	0.0	29.3	12.9	0.0	10.2	8.8	0.0	15.5
Incr Delay (d2), s/veh	1.2	0.2	0.1	0.4	0.0	3.3	0.4	0.0	0.2	0.0	0.0	7.2
Initial Q Delay(d3),s/veh	0.0	0.0	0.0	0.0	0.0	0.0	0.0	0.0	0.0	0.0	0.0	0.0
%ile BackOfQ(50%),veh/ln	8.3	0.7	0.2	0.8	0.0	0.9	0.3	0.0	2.2	0.1	0.0	10.0
Unsig. Movement Delay, s/veh												
LnGrp Delay(d),s/veh	22.5	22.6	22.0	27.4	0.0	32.6	13.3	0.0	10.4	8.8	0.0	22.7
LnGrp LOS	C	C	C	C	A	C	B	A	B	A	A	C
Approach Vol, veh/h		333			109			328			760	
Approach Delay, s/veh		22.5			30.0			10.8			22.3	
Approach LOS		C			C			B			C	
Timer - Assigned Phs	1	2	3	4	5	6	7	8				
Phs Duration (G+Y+Rc), s	6.7	34.6	14.7	8.4	5.8	35.5	7.0	16.1				
Change Period (Y+Rc), s	4.5	4.5	4.5	4.5	4.5	4.5	4.5	4.5				
Max Green Setting (Gmax), s	4.1	37.8	13.7	16.4	4.1	37.8	4.1	26.0				
Max Q Clear Time (g_c+1), s	12.8	25.9	10.1	3.8	2.4	8.1	3.9	3.7				
Green Ext Time (p_c), s	0.0	4.3	0.3	0.1	0.0	1.8	0.0	0.3				

Intersection Summary

HCM 6th Ctrl Delay	20.4
HCM 6th LOS	C

Intersection

Int Delay, s/veh 347.8

Movement	EBL	EBT	WBT	WBR	SBL	SBR
Lane Configurations						
Traffic Vol, veh/h	145	515	615	313	181	225
Future Vol, veh/h	145	515	615	313	181	225
Conflicting Peds, #/hr	0	0	0	0	3	0
Sign Control	Free	Free	Free	Free	Stop	Stop
RT Channelized	-	None	-	None	-	None
Storage Length	175	-	-	-	0	-
Veh in Median Storage, #	-	0	0	-	0	-
Grade, %	-	0	0	-	0	-
Peak Hour Factor	84	84	84	84	84	84
Heavy Vehicles, %	4	1	1	3	1	0
Mvmt Flow	173	613	732	373	215	268

Major/Minor

	Major1	Major2	Minor2
Conflicting Flow All	1105	0	0
Stage 1	-	-	-
Stage 2	-	-	-
Critical Hdwy	4.14	-	-
Critical Hdwy Stg 1	-	-	-
Critical Hdwy Stg 2	-	-	-
Follow-up Hdwy	2.236	-	-
Pot Cap-1 Maneuver	624	-	-
Stage 1	-	-	-
Stage 2	-	-	-
Platoon blocked, %		-	-
Mov Cap-1 Maneuver	624	-	-
Mov Cap-2 Maneuver	-	-	-
Stage 1	-	-	-
Stage 2	-	-	-

Approach

	EB	WB	SB
HCM Control Delay, s	2.8	0	\$ 1703.4
HCM LOS			F

Minor Lane/Major Mvmt

	EBL	EBT	WBT	WBR	SBLn1
Capacity (veh/h)	624	-	-	-	105
HCM Lane V/C Ratio	0.277	-	-	-	4.603
HCM Control Delay (s)	13	-	-	-	\$1703.4
HCM Lane LOS	B	-	-	-	F
HCM 95th %tile Q(veh)	1.1	-	-	-	50.9

Notes

~: Volume exceeds capacity \$: Delay exceeds 300s +: Computation Not Defined *: All major volume in platoon

Intersection

Int Delay, s/veh 0.1

Movement EBL EBR NBL NBT SBT SBR

Lane Configurations							
Traffic Vol, veh/h	3	3	5	567	785	5	
Future Vol, veh/h	3	3	5	567	785	5	
Conflicting Peds, #/hr	0	0	0	0	0	0	
Sign Control	Stop	Stop	Free	Free	Free	Free	
RT Channelized	-	None	-	None	-	None	
Storage Length	0	-	-	-	-	-	
Veh in Median Storage, #	0	-	-	0	0	-	
Grade, %	0	-	-	0	0	-	
Peak Hour Factor	95	95	95	95	95	95	
Heavy Vehicles, %	0	0	0	1	2	0	
Mvmt Flow	3	3	5	597	826	5	

Major/Minor Minor2 Major1 Major2

Conflicting Flow All	1436	829	831	0	-	0
Stage 1	829	-	-	-	-	-
Stage 2	607	-	-	-	-	-
Critical Hdwy	6.4	6.2	4.1	-	-	-
Critical Hdwy Stg 1	5.4	-	-	-	-	-
Critical Hdwy Stg 2	5.4	-	-	-	-	-
Follow-up Hdwy	3.5	3.3	2.2	-	-	-
Pot Cap-1 Maneuver	149	374	810	-	-	-
Stage 1	432	-	-	-	-	-
Stage 2	548	-	-	-	-	-
Platoon blocked, %				-	-	-
Mov Cap-1 Maneuver	148	374	810	-	-	-
Mov Cap-2 Maneuver	148	-	-	-	-	-
Stage 1	428	-	-	-	-	-
Stage 2	548	-	-	-	-	-

Approach EB NB SB

HCM Control Delay, s	22.5	0.1	0
HCM LOS	C		

Minor Lane/Major Mvmt NBL NBT EBLn1 SBT SBR

Capacity (veh/h)	810	-	212	-	-
HCM Lane V/C Ratio	0.006	-	0.03	-	-
HCM Control Delay (s)	9.5	0	22.5	-	-
HCM Lane LOS	A	A	C	-	-
HCM 95th %tile Q(veh)	0	-	0.1	-	-

Synchro ID	Control Type	Intersection	Control Type	LOS	Delay	V/C Ratio
	1 Signal	Parkway Ave & Boeckman Rd	Signal	D	37.8	0.95
	3 Signal	Wilsonville Rd/Stafford Rd & Boeckman R	Signal	C	20.4	0.76

C. STAGE II LIST



Updated by D. Pauly 07.08.2021

Stage II Approved											
Project	Land Use	Status	Size	Total PM Peak Trips	Trip Allocation		Net New (Primary + Diverted)		PM Peak		
					Internal	Pass-By	In	Out	Total	In	Out
Hydro-Temp: Recent agreement with the City, the project is vested and so are the traffic trips	Office/Flex-Space	Not built	60.8 KSF					44	46		90
Mercedes Benz (Phase 2)	Auto Dealership	Not built						20	26		46
Shredding Systems (SQFT does not including paint canopy and another canopy)	Industrial/Commercial	Under construction	66.8 KSF					20	46		66
TOWN Center Pn III and trip dedication to Miller Paint store	*High Turnover Restaurant (Pad 1)	Not built	7.5 KSF					24	17		47*
Uses marked with "*" have not been built and PM peak in trip sum exceeds remaining vested	Remaining Approved Total										47
trial level hv 2 trips. It has not to be determined	Phase 2 - office (2-story building on west parcel)	Partially Built	21.7 KSF					15	71		86
Wilsonville Road Business Park Phase II											
Universal Health Services	Mental Health Facility	Land Use Expired, Trip available for other uses	62K								107
Frog Pond-Stafford Meadows (Phase 2 and 3a of 10/18 study)	Residential	Partially Built, 20 homes built and occupied	46 units					16	12		26
Frog Pond-Frog Pond Meadows (Phase 3B, 4A, 4B of 10/18 Study)	Residential	Under construction	74 units					45	29		74
Frog Pond Ridge	Residential	ruction, no homes built	71 units					43	28		71
Frog Pond-Morgan Farm	Residential	Partially Built, 33 homes built and occupied	80 units					30	17		47
Fir Avenue Commons	Residential	Built, not yet occupied	10 units					7	3		10
Magnolia Townhomes	Residential	Approved	6 units					3	2		5
Aspen Meadows II	Residential	Under construction, no homes sold and occupied	5 units					2	3		5
Canyon Creek III	Residential	Approved	5 units (traffic study was for 11)					2	3		5
Coffee Creek Logistics	Industrial/Commercial	Under construction	115K					16	41		57

Stage II Approved - Villebois

Project	Phase	Status	Land Use							Total PM Peak Trips	Allocation Percentage		Net New (Primary + Diverted)			
			SF	Town.	Apt.	Retail	School		Internal		Pass-By	In	Out	Total		
North (Entirety)	Residential	Partially built, 364 homes sold and occupied	466											65	37	102

Central	Residential	Partially Built, 734 homes (102 single family, 318 condo/row homes, 365 apartments) occupied	102	391	365	8.5 KSF												30	14	44
FOR REFERENCE SAP EAST																				
FOR REFERENCE SAP SOUTH (includes PDP 7 Grande Pointe)																				
			537	42																

Pending Projects for Which Traffic Analysis has been completed (except Villebois)





















Project	Land Use	Status	Size	Total PM Peak Trips	Trip Allocation Percentage	Net New (Primary) PM Peak Hour Trips	Total
				Internal	Pass-By	In	Out
PW Complex on Boberg	Public	under review	15,800 office, 17,900 warehouse			11	39
DAS North Valley Complex	Public/Industrial	under review	174,700 sf			5	15
							20

D. HCM REPORTS – EXISTING + PROJECT



HCM 6th Signalized Intersection Summary
 1: Parkway Ave & Boeckman Rd

Frog Pond Crossing
 Existing PM + Project

												
Movement	EBL	EBT	EBR	WBL	WBT	WBR	NBL	NBT	NBR	SBL	SBT	SBR
Lane Configurations												
Traffic Volume (veh/h)	103	258	196	90	312	37	155	173	49	44	393	244
Future Volume (veh/h)	103	258	196	90	312	37	155	173	49	44	393	244
Initial Q (Qb), veh	0	0	0	0	0	0	0	0	0	0	0	0
Ped-Bike Adj(A_pbT)	1.00		0.97	1.00		0.97	1.00		0.97	1.00		0.97
Parking Bus, Adj	1.00	1.00	1.00	1.00	1.00	1.00	1.00	1.00	1.00	1.00	1.00	1.00
Work Zone On Approach		No			No			No			No	
Adj Sat Flow, veh/h/ln	1930	1885	1885	1870	1856	1900	1885	1856	1870	1976	1976	1900
Adj Flow Rate, veh/h	112	280	180	98	339	36	168	188	42	48	427	239
Peak Hour Factor	0.92	0.92	0.92	0.92	0.92	0.92	0.92	0.92	0.92	0.92	0.92	0.92
Percent Heavy Veh, %	3	1	1	2	3	0	1	3	2	0	0	0
Cap, veh/h	291	297	191	207	453	48	249	626	140	563	452	253
Arrive On Green	0.06	0.28	0.28	0.06	0.28	0.28	0.08	0.43	0.43	0.03	0.38	0.38
Sat Flow, veh/h	1838	1057	680	1781	1644	175	1795	1460	326	1882	1178	659
Grp Volume(v), veh/h	112	0	460	98	0	375	168	0	230	48	0	666
Grp Sat Flow(s),veh/h/ln	1838	0	1737	1781	0	1818	1795	0	1787	1882	0	1837
Q Serve(g_s), s	3.6	0.0	21.8	3.3	0.0	15.9	4.5	0.0	7.1	1.3	0.0	29.5
Cycle Q Clear(g_c), s	3.6	0.0	21.8	3.3	0.0	15.9	4.5	0.0	7.1	1.3	0.0	29.5
Prop In Lane	1.00		0.39	1.00		0.10	1.00		0.18	1.00		0.36
Lane Grp Cap(c), veh/h	291	0	488	207	0	501	249	0	765	563	0	705
V/C Ratio(X)	0.39	0.00	0.94	0.47	0.00	0.75	0.68	0.00	0.30	0.09	0.00	0.94
Avail Cap(c_a), veh/h	350	0	488	275	0	511	282	0	765	681	0	726
HCM Platoon Ratio	1.00	1.00	1.00	1.00	1.00	1.00	1.00	1.00	1.00	1.00	1.00	1.00
Upstream Filter(l)	1.00	0.00	1.00	1.00	0.00	1.00	1.00	0.00	1.00	1.00	0.00	1.00
Uniform Delay (d), s/veh	21.3	0.0	29.6	22.9	0.0	27.9	19.2	0.0	15.8	14.8	0.0	25.1
Incr Delay (d2), s/veh	0.8	0.0	26.9	1.7	0.0	5.9	5.3	0.0	0.2	0.1	0.0	20.7
Initial Q Delay(d3),s/veh	0.0	0.0	0.0	0.0	0.0	0.0	0.0	0.0	0.0	0.0	0.0	0.0
%ile BackOfQ(50%),veh/ln	1.6	0.0	12.4	1.4	0.0	7.5	2.1	0.0	2.8	0.5	0.0	16.1
Unsig. Movement Delay, s/veh												
LnGrp Delay(d),s/veh	22.2	0.0	56.5	24.6	0.0	33.8	24.5	0.0	16.0	14.9	0.0	45.8
LnGrp LOS	C	A	E	C	A	C	C	A	B	B	A	D
Approach Vol, veh/h		572			473			398			714	
Approach Delay, s/veh		49.8			31.9			19.6			43.7	
Approach LOS		D			C			B			D	
Timer - Assigned Phs	1	2	3	4	5	6	7	8				
Phs Duration (G+Y+Rc), s	10.5	36.9	8.8	28.2	6.7	40.6	9.3	27.7				
Change Period (Y+Rc), s	4.0	4.5	4.0	4.5	4.0	4.5	4.0	4.5				
Max Green Setting (Gmax), s	8.0	33.3	8.0	23.7	8.0	33.3	8.0	23.7				
Max Q Clear Time (g_c+I1), s	6.5	31.5	5.3	23.8	3.3	9.1	5.6	17.9				
Green Ext Time (p_c), s	0.1	0.8	0.0	0.0	0.0	1.3	0.1	1.1				
Intersection Summary												
HCM 6th Ctrl Delay			38.3									
HCM 6th LOS			D									

Intersection												
Intersection Delay, s/veh	25.3											
Intersection LOS	D											

Movement	EBL	EBT	EBR	WBL	WBT	WBR	NBL	NBT	NBR	SBL	SBT	SBR
Lane Configurations												
Traffic Vol, veh/h	81	320	52	90	236	50	23	99	81	101	180	71
Future Vol, veh/h	81	320	52	90	236	50	23	99	81	101	180	71
Peak Hour Factor	0.93	0.93	0.93	0.93	0.93	0.93	0.93	0.93	0.93	0.93	0.93	0.93
Heavy Vehicles, %	1	1	0	2	2	4	0	1	0	1	1	1
Mvmt Flow	87	344	56	97	254	54	25	106	87	109	194	76
Number of Lanes	1	1	0	1	1	0	1	1	0	1	1	0

Approach	EB	WB	NB	SB
Opposing Approach	WB	EB	SB	NB
Opposing Lanes	2	2	2	2
Conflicting Approach Left	SB	NB	EB	WB
Conflicting Lanes Left	2	2	2	2
Conflicting Approach Right	NB	SB	WB	EB
Conflicting Lanes Right	2	2	2	2
HCM Control Delay	35.8	22.4	16.9	19.8
HCM LOS	E	C	C	C

Lane	NBLn1	NBLn2	EBLn1	EBLn2	WBLn1	WBLn2	SBLn1	SBLn2
Vol Left, %	100%	0%	100%	0%	100%	0%	100%	0%
Vol Thru, %	0%	55%	0%	86%	0%	83%	0%	72%
Vol Right, %	0%	45%	0%	14%	0%	17%	0%	28%
Sign Control	Stop	Stop	Stop	Stop	Stop	Stop	Stop	Stop
Traffic Vol by Lane	23	180	81	372	90	286	101	251
LT Vol	23	0	81	0	90	0	101	0
Through Vol	0	99	0	320	0	236	0	180
RT Vol	0	81	0	52	0	50	0	71
Lane Flow Rate	25	194	87	400	97	308	109	270
Geometry Grp	7	7	7	7	7	7	7	7
Degree of Util (X)	0.063	0.445	0.2	0.852	0.228	0.671	0.263	0.599
Departure Headway (Hd)	9.108	8.279	8.284	7.668	8.498	7.855	8.709	7.986
Convergence, Y/N	Yes	Yes	Yes	Yes	Yes	Yes	Yes	Yes
Cap	393	435	435	472	424	461	414	453
Service Time	6.86	6.03	6.015	5.399	6.232	5.589	6.443	5.72
HCM Lane V/C Ratio	0.064	0.446	0.2	0.847	0.229	0.668	0.263	0.596
HCM Control Delay	12.5	17.5	13.1	40.8	13.7	25.2	14.5	22
HCM Lane LOS	B	C	B	E	B	D	B	C
HCM 95th-tile Q	0.2	2.2	0.7	8.6	0.9	4.9	1	3.8

HCM 6th Signalized Intersection Summary
 3: Wilsonville Rd/Stafford Rd & Boeckman Rd/Advance Rd

Frog Pond Crossing
 Existing PM + Project



Movement	EBL	EBT	EBR	WBL	WBT	WBR	NBL	NBT	NBR	SBL	SBT	SBR
Lane Configurations												
Traffic Volume (veh/h)	245	56	87	52	49	18	42	226	52	22	477	243
Future Volume (veh/h)	245	56	87	52	49	18	42	226	52	22	477	243
Initial Q (Qb), veh	0	0	0	0	0	0	0	0	0	0	0	0
Ped-Bike Adj(A_pbT)	1.00		1.00	0.99		0.99	1.00		1.00	1.00		1.00
Parking Bus, Adj	1.00	1.00	1.00	1.00	1.00	1.00	1.00	1.00	1.00	1.00	1.00	1.00
Work Zone On Approach		No			No			No			No	
Adj Sat Flow, veh/h/ln	1885	1870	1900	1811	1870	1900	1870	1900	1841	1752	1900	1841
Adj Flow Rate, veh/h	258	59	17	55	52	2	44	238	47	23	502	237
Peak Hour Factor	0.95	0.95	0.95	0.95	0.95	0.95	0.95	0.95	0.95	0.95	0.95	0.95
Percent Heavy Veh, %	1	2	0	6	2	0	2	0	4	10	0	4
Cap, veh/h	440	337	289	254	107	4	241	741	146	542	571	270
Arrive On Green	0.16	0.18	0.18	0.04	0.06	0.06	0.03	0.48	0.48	0.02	0.47	0.47
Sat Flow, veh/h	1795	1870	1606	1725	1789	69	1781	1541	304	1668	1220	576
Grp Volume(v), veh/h	258	59	17	55	0	54	44	0	285	23	0	739
Grp Sat Flow(s),veh/h/ln	1795	1870	1606	1725	0	1857	1781	0	1845	1668	0	1796
Q Serve(g_s), s	8.1	1.7	0.6	1.9	0.0	1.8	0.8	0.0	6.1	0.5	0.0	24.0
Cycle Q Clear(g_c), s	8.1	1.7	0.6	1.9	0.0	1.8	0.8	0.0	6.1	0.5	0.0	24.0
Prop In Lane	1.00		1.00	1.00		0.04	1.00		0.16	1.00		0.32
Lane Grp Cap(c), veh/h	440	337	289	254	0	111	241	0	888	542	0	841
V/C Ratio(X)	0.59	0.18	0.06	0.22	0.00	0.49	0.18	0.00	0.32	0.04	0.00	0.88
Avail Cap(c_a), veh/h	538	753	647	297	0	469	294	0	1080	613	0	1052
HCM Platoon Ratio	1.00	1.00	1.00	1.00	1.00	1.00	1.00	1.00	1.00	1.00	1.00	1.00
Upstream Filter(l)	1.00	1.00	1.00	1.00	0.00	1.00	1.00	0.00	1.00	1.00	0.00	1.00
Uniform Delay (d), s/veh	21.3	22.4	21.9	27.1	0.0	29.4	13.0	0.0	10.3	8.8	0.0	15.5
Incr Delay (d2), s/veh	1.2	0.2	0.1	0.4	0.0	3.3	0.4	0.0	0.2	0.0	0.0	7.3
Initial Q Delay(d3),s/veh	0.0	0.0	0.0	0.0	0.0	0.0	0.0	0.0	0.0	0.0	0.0	0.0
%ile BackOfQ(50%),veh/ln	8.3	0.7	0.2	0.8	0.0	0.9	0.3	0.0	2.2	0.2	0.0	10.1
Unsig. Movement Delay, s/veh												
LnGrp Delay(d),s/veh	22.6	22.6	22.0	27.5	0.0	32.7	13.3	0.0	10.5	8.8	0.0	22.8
LnGrp LOS	C	C	C	C	A	C	B	A	B	A	A	C
Approach Vol, veh/h		334			109			329			762	
Approach Delay, s/veh		22.6			30.1			10.9			22.4	
Approach LOS		C			C			B			C	
Timer - Assigned Phs	1	2	3	4	5	6	7	8				
Phs Duration (G+Y+Rc), s	6.7	34.7	14.8	8.4	5.9	35.6	7.0	16.1				
Change Period (Y+Rc), s	4.5	4.5	4.5	4.5	4.5	4.5	4.5	4.5				
Max Green Setting (Gmax), s	4.1	37.8	13.8	16.3	4.1	37.8	4.1	26.0				
Max Q Clear Time (g_c+1.2), s	12.8	26.0	10.1	3.8	2.5	8.1	3.9	3.7				
Green Ext Time (p_c), s	0.0	4.2	0.3	0.1	0.0	1.8	0.0	0.3				

Intersection Summary

HCM 6th Ctrl Delay	20.5
HCM 6th LOS	C

Intersection

Int Delay, s/veh 367.1

Movement	EBL	EBT	WBT	WBR	SBL	SBR
Lane Configurations						
Traffic Vol, veh/h	148	517	618	313	181	232
Future Vol, veh/h	148	517	618	313	181	232
Conflicting Peds, #/hr	0	0	0	0	3	0
Sign Control	Free	Free	Free	Free	Stop	Stop
RT Channelized	-	None	-	None	-	None
Storage Length	175	-	-	-	0	-
Veh in Median Storage, #	-	0	0	-	0	-
Grade, %	-	0	0	-	0	-
Peak Hour Factor	84	84	84	84	84	84
Heavy Vehicles, %	4	1	1	3	1	0
Mvmt Flow	176	615	736	373	215	276

Major/Minor

	Major1	Major2	Minor2		
Conflicting Flow All	1109	0	0	1893	923
Stage 1	-	-	-	923	-
Stage 2	-	-	-	970	-
Critical Hdwy	4.14	-	-	6.41	6.2
Critical Hdwy Stg 1	-	-	-	5.41	-
Critical Hdwy Stg 2	-	-	-	5.41	-
Follow-up Hdwy	2.236	-	-	3.509	3.3
Pot Cap-1 Maneuver	622	-	-	~ 77	330
Stage 1	-	-	-	389	-
Stage 2	-	-	-	369	-
Platoon blocked, %		-	-		
Mov Cap-1 Maneuver	622	-	-	~ 55	330
Mov Cap-2 Maneuver	-	-	-	~ 55	-
Stage 1	-	-	-	279	-
Stage 2	-	-	-	369	-

Approach

	EB	WB	SB
HCM Control Delay, s	2.9	0	\$ 1781.1
HCM LOS			F

Minor Lane/Major Mvmt

	EBL	EBT	WBT	WBR	SBLn1
Capacity (veh/h)	622	-	-	-	103
HCM Lane V/C Ratio	0.283	-	-	-	4.773
HCM Control Delay (s)	13.1	-	-	-	\$ 1781.1
HCM Lane LOS	B	-	-	-	F
HCM 95th %tile Q(veh)	1.2	-	-	-	52.1

Notes

~: Volume exceeds capacity \$: Delay exceeds 300s +: Computation Not Defined *: All major volume in platoon

Intersection						
Int Delay, s/veh	0.3					
Movement	EBL	EBR	NBL	NBT	SBT	SBR
Lane Configurations						
Traffic Vol, veh/h	8	5	8	567	785	15
Future Vol, veh/h	8	5	8	567	785	15
Conflicting Peds, #/hr	0	0	0	0	0	0
Sign Control	Stop	Stop	Free	Free	Free	Free
RT Channelized	-	None	-	None	-	None
Storage Length	0	-	-	-	-	-
Veh in Median Storage, #	0	-	-	0	0	-
Grade, %	0	-	-	0	0	-
Peak Hour Factor	95	95	95	95	95	95
Heavy Vehicles, %	0	0	0	1	2	0
Mvmt Flow	8	5	8	597	826	16

Major/Minor	Minor2	Major1		Major2	
Conflicting Flow All	1447	834	842	0	0
Stage 1	834	-	-	-	-
Stage 2	613	-	-	-	-
Critical Hdwy	6.4	6.2	4.1	-	-
Critical Hdwy Stg 1	5.4	-	-	-	-
Critical Hdwy Stg 2	5.4	-	-	-	-
Follow-up Hdwy	3.5	3.3	2.2	-	-
Pot Cap-1 Maneuver	146	371	802	-	-
Stage 1	430	-	-	-	-
Stage 2	544	-	-	-	-
Platoon blocked, %				-	-
Mov Cap-1 Maneuver	144	371	802	-	-
Mov Cap-2 Maneuver	144	-	-	-	-
Stage 1	424	-	-	-	-
Stage 2	544	-	-	-	-

Approach	EB	NB	SB
HCM Control Delay, s	25.6	0.1	0
HCM LOS	D		

Minor Lane/Major Mvmt	NBL	NBT	EBLn1	SBT	SBR
Capacity (veh/h)	802	-	188	-	-
HCM Lane V/C Ratio	0.011	-	0.073	-	-
HCM Control Delay (s)	9.5	0	25.6	-	-
HCM Lane LOS	A	A	D	-	-
HCM 95th %tile Q(veh)	0	-	0.2	-	-





















Synchro ID	Control Type	Intersection	Control Type	LOS	Delay	V/C Ratio
	1 Signal	Parkway Ave & Boeckman Rd	Signal	D	38.3	0.96
	3 Signal	Wilsonville Rd/Stafford Rd & Boeckman R	Signal	C	20.5	0.76

E. HCM REPORTS – EXISTING + STAGE II



HCM 6th Signalized Intersection Summary
1: Parkway Ave & Boeckman Rd

Frog Pond Crossing
Existing PM + Stage II

												
Movement	EBL	EBT	EBR	WBL	WBT	WBR	NBL	NBT	NBR	SBL	SBT	SBR
Lane Configurations												
Traffic Volume (veh/h)	108	293	198	95	344	40	157	174	56	50	394	251
Future Volume (veh/h)	108	293	198	95	344	40	157	174	56	50	394	251
Initial Q (Qb), veh	0	0	0	0	0	0	0	0	0	0	0	0
Ped-Bike Adj(A_pbT)	1.00		0.97	1.00		0.97	1.00		0.97	1.00		0.97
Parking Bus, Adj	1.00	1.00	1.00	1.00	1.00	1.00	1.00	1.00	1.00	1.00	1.00	1.00
Work Zone On Approach		No			No			No			No	
Adj Sat Flow, veh/h/ln	1930	1885	1885	1870	1856	1900	1885	1856	1870	1976	1976	1900
Adj Flow Rate, veh/h	117	318	189	103	374	39	171	189	49	54	428	248
Peak Hour Factor	0.92	0.92	0.92	0.92	0.92	0.92	0.92	0.92	0.92	0.92	0.92	0.92
Percent Heavy Veh, %	3	1	1	2	3	0	1	3	2	0	0	0
Cap, veh/h	279	329	196	190	487	51	234	610	158	550	451	262
Arrive On Green	0.06	0.30	0.30	0.06	0.30	0.30	0.07	0.43	0.43	0.03	0.39	0.39
Sat Flow, veh/h	1838	1094	650	1781	1647	172	1795	1412	366	1882	1161	673
Grp Volume(v), veh/h	117	0	507	103	0	413	171	0	238	54	0	676
Grp Sat Flow(s),veh/h/ln	1838	0	1744	1781	0	1819	1795	0	1778	1882	0	1834
Q Serve(g_s), s	4.2	0.0	27.3	3.8	0.0	19.7	5.2	0.0	8.4	1.6	0.0	34.0
Cycle Q Clear(g_c), s	4.2	0.0	27.3	3.8	0.0	19.7	5.2	0.0	8.4	1.6	0.0	34.0
Prop In Lane	1.00		0.37	1.00		0.09	1.00		0.21	1.00		0.37
Lane Grp Cap(c), veh/h	279	0	525	190	0	538	234	0	768	550	0	713
V/C Ratio(X)	0.42	0.00	0.97	0.54	0.00	0.77	0.73	0.00	0.31	0.10	0.00	0.95
Avail Cap(c_a), veh/h	319	0	525	238	0	547	251	0	768	647	0	737
HCM Platoon Ratio	1.00	1.00	1.00	1.00	1.00	1.00	1.00	1.00	1.00	1.00	1.00	1.00
Upstream Filter(I)	1.00	0.00	1.00	1.00	0.00	1.00	1.00	0.00	1.00	1.00	0.00	1.00
Uniform Delay (d), s/veh	23.3	0.0	32.9	25.3	0.0	30.6	21.8	0.0	17.8	16.6	0.0	28.2
Incr Delay (d2), s/veh	1.0	0.0	30.7	2.4	0.0	6.4	9.6	0.0	0.2	0.1	0.0	21.1
Initial Q Delay(d3),s/veh	0.0	0.0	0.0	0.0	0.0	0.0	0.0	0.0	0.0	0.0	0.0	0.0
%ile BackOfQ(50%),veh/ln	1.8	0.0	15.6	1.7	0.0	9.4	2.7	0.0	3.4	0.7	0.0	18.4
Unsig. Movement Delay, s/veh												
LnGrp Delay(d),s/veh	24.3	0.0	63.6	27.7	0.0	37.0	31.4	0.0	18.0	16.6	0.0	49.3
LnGrp LOS	C	A	E	C	A	D	C	A	B	B	A	D
Approach Vol, veh/h		624			516			409			730	
Approach Delay, s/veh		56.2			35.1			23.6			46.9	
Approach LOS		E			D			C			D	
Timer - Assigned Phs	1	2	3	4	5	6	7	8				
Phs Duration (G+Y+Rc), s	11.1	41.6	9.4	33.2	7.0	45.7	9.9	32.7				
Change Period (Y+Rc), s	4.0	4.5	4.0	4.5	4.0	4.5	4.0	4.5				
Max Green Setting (Gmax), s	8.0	38.3	8.0	28.7	8.0	38.3	8.0	28.7				
Max Q Clear Time (g_c+I1), s	7.2	36.0	5.8	29.3	3.6	10.4	6.2	21.7				
Green Ext Time (p_c), s	0.0	1.1	0.0	0.0	0.0	1.5	0.0	1.4				
Intersection Summary												
HCM 6th Ctrl Delay			42.6									
HCM 6th LOS			D									

Intersection

Intersection Delay, s/veh 37.7
Intersection LOS E

Movement	EBL	EBT	EBR	WBL	WBT	WBR	NBL	NBT	NBR	SBL	SBT	SBR
Lane Configurations												
Traffic Vol, veh/h	86	361	54	94	269	59	26	101	87	116	181	75
Future Vol, veh/h	86	361	54	94	269	59	26	101	87	116	181	75
Peak Hour Factor	0.93	0.93	0.93	0.93	0.93	0.93	0.93	0.93	0.93	0.93	0.93	0.93
Heavy Vehicles, %	1	1	0	2	2	4	0	1	0	1	1	1
Mvmt Flow	92	388	58	101	289	63	28	109	94	125	195	81
Number of Lanes	1	1	0	1	1	0	1	1	0	1	1	0

Approach	EB	WB	NB	SB
Opposing Approach	WB	EB	SB	NB
Opposing Lanes	2	2	2	2
Conflicting Approach Left SB		NB	EB	WB
Conflicting Lanes Left	2	2	2	2
Conflicting Approach Right NB		SB	WB	EB
Conflicting Lanes Right	2	2	2	2
HCM Control Delay	61.9	31.9	18.9	22.3
HCM LOS	F	D	C	C

Lane	NBLn1	NBLn2	EBLn1	EBLn2	WBLn1	WBLn2	SBLn1	SBLn2
Vol Left, %	100%	0%	100%	0%	100%	0%	100%	0%
Vol Thru, %	0%	54%	0%	87%	0%	82%	0%	71%
Vol Right, %	0%	46%	0%	13%	0%	18%	0%	29%
Sign Control	Stop	Stop	Stop	Stop	Stop	Stop	Stop	Stop
Traffic Vol by Lane	26	188	86	415	94	328	116	256
LT Vol	26	0	86	0	94	0	116	0
Through Vol	0	101	0	361	0	269	0	181
RT Vol	0	87	0	54	0	59	0	75
Lane Flow Rate	28	202	92	446	101	353	125	275
Geometry Grp	7	7	7	7	7	7	7	7
Degree of Util (X)	0.074	0.488	0.223	1.003	0.247	0.801	0.314	0.639
Departure Headway (Hd)	9.719	8.875	8.7	8.089	8.952	8.303	9.255	8.521
Convergence, Y/N	Yes	Yes	Yes	Yes	Yes	Yes	Yes	Yes
Cap	371	408	415	451	403	437	390	427
Service Time	7.419	6.575	6.398	5.787	6.652	6.003	6.955	6.221
HCM Lane V/C Ratio	0.075	0.495	0.222	0.989	0.251	0.808	0.321	0.644
HCM Control Delay	13.2	19.7	13.9	71.9	14.6	36.9	16.1	25.1
HCM Lane LOS	B	C	B	F	B	E	C	D
HCM 95th-tile Q	0.2	2.6	0.8	13	1	7.2	1.3	4.3

HCM 6th Signalized Intersection Summary
 3: Wilsonville Rd/Stafford Rd & Boeckman Rd/Advance Rd

Frog Pond Crossing
 Existing PM + Stage II



Movement	EBL	EBT	EBR	WBL	WBT	WBR	NBL	NBT	NBR	SBL	SBT	SBR
Lane Configurations												
Traffic Volume (veh/h)	291	67	98	52	67	17	57	228	53	21	478	313
Future Volume (veh/h)	291	67	98	52	67	17	57	228	53	21	478	313
Initial Q (Qb), veh	0	0	0	0	0	0	0	0	0	0	0	0
Ped-Bike Adj(A_pbT)	1.00		1.00	0.99		0.99	1.00		1.00	1.00		1.00
Parking Bus, Adj	1.00	1.00	1.00	1.00	1.00	1.00	1.00	1.00	1.00	1.00	1.00	1.00
Work Zone On Approach		No			No			No			No	
Adj Sat Flow, veh/h/ln	1885	1870	1900	1811	1870	1900	1870	1900	1841	1752	1900	1841
Adj Flow Rate, veh/h	306	71	19	55	71	5	60	240	48	22	503	305
Peak Hour Factor	0.95	0.95	0.95	0.95	0.95	0.95	0.95	0.95	0.95	0.95	0.95	0.95
Percent Heavy Veh, %	1	2	0	6	2	0	2	0	4	10	0	4
Cap, veh/h	424	357	307	251	120	8	207	777	155	554	539	327
Arrive On Green	0.16	0.19	0.19	0.04	0.07	0.07	0.04	0.51	0.51	0.02	0.49	0.49
Sat Flow, veh/h	1795	1870	1606	1725	1726	122	1781	1537	307	1668	1108	672
Grp Volume(v), veh/h	306	71	19	55	0	76	60	0	288	22	0	808
Grp Sat Flow(s),veh/h/ln	1795	1870	1606	1725	0	1847	1781	0	1845	1668	0	1779
Q Serve(g_s), s	11.2	2.3	0.7	2.2	0.0	2.9	1.2	0.0	6.7	0.5	0.0	31.3
Cycle Q Clear(g_c), s	11.2	2.3	0.7	2.2	0.0	2.9	1.2	0.0	6.7	0.5	0.0	31.3
Prop In Lane	1.00		1.00	1.00		0.07	1.00		0.17	1.00		0.38
Lane Grp Cap(c), veh/h	424	357	307	251	0	128	207	0	933	554	0	866
V/C Ratio(X)	0.72	0.20	0.06	0.22	0.00	0.59	0.29	0.00	0.31	0.04	0.00	0.93
Avail Cap(c_a), veh/h	424	663	569	280	0	461	236	0	956	613	0	922
HCM Platoon Ratio	1.00	1.00	1.00	1.00	1.00	1.00	1.00	1.00	1.00	1.00	1.00	1.00
Upstream Filter(I)	1.00	1.00	1.00	1.00	0.00	1.00	1.00	0.00	1.00	1.00	0.00	1.00
Uniform Delay (d), s/veh	24.7	24.9	24.3	30.2	0.0	33.1	15.9	0.0	10.6	9.2	0.0	17.7
Incr Delay (d2), s/veh	5.9	0.3	0.1	0.4	0.0	4.3	0.8	0.0	0.2	0.0	0.0	15.4
Initial Q Delay(d3),s/veh	0.0	0.0	0.0	0.0	0.0	0.0	0.0	0.0	0.0	0.0	0.0	0.0
%ile BackOfQ(50%),veh/ln	5.2	1.0	0.3	0.9	0.0	1.4	0.5	0.0	2.5	0.2	0.0	14.9
Unsig. Movement Delay, s/veh												
LnGrp Delay(d),s/veh	30.6	25.2	24.4	30.6	0.0	37.4	16.6	0.0	10.8	9.3	0.0	33.1
LnGrp LOS	C	C	C	C	A	D	B	A	B	A	A	C
Approach Vol, veh/h		396			131			348			830	
Approach Delay, s/veh		29.3			34.5			11.8			32.4	
Approach LOS		C			C			B			C	
Timer - Assigned Phs	1	2	3	4	5	6	7	8				
Phs Duration (G+Y+Rc), s	7.3	40.2	16.2	9.6	5.9	41.6	7.3	18.5				
Change Period (Y+Rc), s	4.5	4.5	4.5	4.5	4.5	4.5	4.5	4.5				
Max Green Setting (Gmax), s	4.0	38.0	11.7	18.3	4.0	38.0	4.0	26.0				
Max Q Clear Time (g_c+1), s	13.2	33.3	13.2	4.9	2.5	8.7	4.2	4.3				
Green Ext Time (p_c), s	0.0	2.4	0.0	0.2	0.0	1.8	0.0	0.3				

Intersection Summary

HCM 6th Ctrl Delay	27.7
HCM 6th LOS	C

Intersection

Int Delay, s/veh 511.9

Movement	EBL	EBT	WBT	WBR	SBL	SBR
Lane Configurations						
Traffic Vol, veh/h	182	528	633	313	181	279
Future Vol, veh/h	182	528	633	313	181	279
Conflicting Peds, #/hr	0	0	0	0	3	0
Sign Control	Free	Free	Free	Free	Stop	Stop
RT Channelized	-	None	-	None	-	None
Storage Length	175	-	-	-	0	-
Veh in Median Storage, #	-	0	0	-	0	-
Grade, %	-	0	0	-	0	-
Peak Hour Factor	84	84	84	84	84	84
Heavy Vehicles, %	4	1	1	3	1	0
Mvmt Flow	217	629	754	373	215	332

Major/Minor	Major1	Major2	Minor2
Conflicting Flow All	1127	0	0 2007 941
Stage 1	-	-	- 941 -
Stage 2	-	-	- 1066 -
Critical Hdwy	4.14	-	- 6.41 6.2
Critical Hdwy Stg 1	-	-	- 5.41 -
Critical Hdwy Stg 2	-	-	- 5.41 -
Follow-up Hdwy	2.236	-	- 3.509 3.3
Pot Cap-1 Maneuver	613	-	- ~ 66 ~ 322
Stage 1	-	-	- 381 -
Stage 2	-	-	- 332 -
Platoon blocked, %		-	-
Mov Cap-1 Maneuver	613	-	- ~ 43 ~ 322
Mov Cap-2 Maneuver	-	-	- ~ 43 -
Stage 1	-	-	- 246 -
Stage 2	-	-	- 332 -

Approach	EB	WB	SB
HCM Control Delay, s	3.6	0	\$ 2349.1
HCM LOS			F

Minor Lane/Major Mvmt	EBL	EBT	WBT	WBR	SBLn1
Capacity (veh/h)	613	-	-	-	91
HCM Lane V/C Ratio	0.353	-	-	-	6.018
HCM Control Delay (s)	14	-	-	-	\$ 2349.1
HCM Lane LOS	B	-	-	-	F
HCM 95th %tile Q(veh)	1.6	-	-	-	60.5

Notes

~: Volume exceeds capacity \$: Delay exceeds 300s +: Computation Not Defined *: All major volume in platoon

Intersection						
Int Delay, s/veh	0.1					
Movement	EBL	EBR	NBL	NBT	SBT	SBR
Lane Configurations	Y			4	4	
Traffic Vol, veh/h	3	3	5	617	857	5
Future Vol, veh/h	3	3	5	617	857	5
Conflicting Peds, #/hr	0	0	0	0	0	0
Sign Control	Stop	Stop	Free	Free	Free	Free
RT Channelized	-	None	-	None	-	None
Storage Length	0	-	-	-	-	-
Veh in Median Storage, #	0	-	-	0	0	-
Grade, %	0	-	-	0	0	-
Peak Hour Factor	95	95	95	95	95	95
Heavy Vehicles, %	0	0	0	1	2	0
Mvmt Flow	3	3	5	649	902	5

Major/Minor	Minor2	Major1		Major2	
Conflicting Flow All	1564	905	907	0	0
Stage 1	905	-	-	-	-
Stage 2	659	-	-	-	-
Critical Hdwy	6.4	6.2	4.1	-	-
Critical Hdwy Stg 1	5.4	-	-	-	-
Critical Hdwy Stg 2	5.4	-	-	-	-
Follow-up Hdwy	3.5	3.3	2.2	-	-
Pot Cap-1 Maneuver	124	338	759	-	-
Stage 1	398	-	-	-	-
Stage 2	518	-	-	-	-
Platoon blocked, %				-	-
Mov Cap-1 Maneuver	123	338	759	-	-
Mov Cap-2 Maneuver	123	-	-	-	-
Stage 1	394	-	-	-	-
Stage 2	518	-	-	-	-

Approach	EB	NB	SB
HCM Control Delay, s	25.7	0.1	0
HCM LOS	D		

Minor Lane/Major Mvmt	NBL	NBT	EBLn1	SBT	SBR
Capacity (veh/h)	759	-	180	-	-
HCM Lane V/C Ratio	0.007	-	0.035	-	-
HCM Control Delay (s)	9.8	0	25.7	-	-
HCM Lane LOS	A	A	D	-	-
HCM 95th %tile Q(veh)	0	-	0.1	-	-

Synchro ID	Control Type	Intersection	Control Type	LOS	Delay	V/C Ratio
	1 Signal	Parkway Ave & Boeckman Rd	Signal	D	42.6	0.98
	3 Signal	Wilsonville Rd/Stafford Rd & Boeckman R	Signal	C	27.7	0.87

F. HCM REPORTS – EXISTING + PROJECT + STAGE II



HCM 6th Signalized Intersection Summary
1: Parkway Ave & Boeckman Rd

Frog Pond Crossing
Existing PM + Project + Stage II

Movement	EBL	EBT	EBR	WBL	WBT	WBR	NBL	NBT	NBR	SBL	SBT	SBR
Lane Configurations												
Traffic Volume (veh/h)	108	296	198	96	345	41	157	174	57	51	394	251
Future Volume (veh/h)	108	296	198	96	345	41	157	174	57	51	394	251
Initial Q (Qb), veh	0	0	0	0	0	0	0	0	0	0	0	0
Ped-Bike Adj(A_pbT)	1.00		0.97	1.00		0.97	1.00		0.97	1.00		0.97
Parking Bus, Adj	1.00	1.00	1.00	1.00	1.00	1.00	1.00	1.00	1.00	1.00	1.00	1.00
Work Zone On Approach		No			No			No			No	
Adj Sat Flow, veh/h/ln	1930	1885	1885	1870	1856	1900	1885	1856	1870	1976	1976	1900
Adj Flow Rate, veh/h	117	322	189	104	375	41	171	189	50	55	428	248
Peak Hour Factor	0.92	0.92	0.92	0.92	0.92	0.92	0.92	0.92	0.92	0.92	0.92	0.92
Percent Heavy Veh, %	3	1	1	2	3	0	1	3	2	0	0	0
Cap, veh/h	283	337	198	194	495	54	229	601	159	543	447	259
Arrive On Green	0.06	0.31	0.31	0.06	0.30	0.30	0.08	0.43	0.43	0.03	0.38	0.38
Sat Flow, veh/h	1838	1099	645	1781	1638	179	1795	1405	372	1882	1161	673
Grp Volume(v), veh/h	117	0	511	104	0	416	171	0	239	55	0	676
Grp Sat Flow(s),veh/h/ln	1838	0	1745	1781	0	1817	1795	0	1777	1882	0	1834
Q Serve(g_s), s	4.2	0.0	27.6	3.8	0.0	19.9	5.3	0.0	8.6	1.7	0.0	34.6
Cycle Q Clear(g_c), s	4.2	0.0	27.6	3.8	0.0	19.9	5.3	0.0	8.6	1.7	0.0	34.6
Prop In Lane	1.00		0.37	1.00		0.10	1.00		0.21	1.00		0.37
Lane Grp Cap(c), veh/h	283	0	535	194	0	549	229	0	760	543	0	706
V/C Ratio(X)	0.41	0.00	0.96	0.54	0.00	0.76	0.75	0.00	0.31	0.10	0.00	0.96
Avail Cap(c_a), veh/h	322	0	535	240	0	557	244	0	760	639	0	714
HCM Platoon Ratio	1.00	1.00	1.00	1.00	1.00	1.00	1.00	1.00	1.00	1.00	1.00	1.00
Upstream Filter(I)	1.00	0.00	1.00	1.00	0.00	1.00	1.00	0.00	1.00	1.00	0.00	1.00
Uniform Delay (d), s/veh	23.2	0.0	32.7	25.2	0.0	30.4	22.1	0.0	18.2	17.0	0.0	28.9
Incr Delay (d2), s/veh	1.0	0.0	28.0	2.3	0.0	5.9	11.2	0.0	0.2	0.1	0.0	23.7
Initial Q Delay(d3),s/veh	0.0	0.0	0.0	0.0	0.0	0.0	0.0	0.0	0.0	0.0	0.0	0.0
%ile BackOfQ(50%),veh/ln	1.8	0.0	15.5	1.7	0.0	9.4	2.8	0.0	3.5	0.7	0.0	19.2
Unsig. Movement Delay, s/veh												
LnGrp Delay(d),s/veh	24.1	0.0	60.8	27.5	0.0	36.3	33.3	0.0	18.4	17.1	0.0	52.5
LnGrp LOS	C	A	E	C	A	D	C	A	B	B	A	D
Approach Vol, veh/h		628			520			410			731	
Approach Delay, s/veh		53.9			34.5			24.7			49.9	
Approach LOS		D			C			C			D	
Timer - Assigned Phs	1	2	3	4	5	6	7	8				
Phs Duration (G+Y+Rc), s	11.2	41.5	9.5	34.0	7.1	45.7	9.9	33.6				
Change Period (Y+Rc), s	4.0	4.5	4.0	4.5	4.0	4.5	4.0	4.5				
Max Green Setting (Gmax), s	8.0	37.5	8.0	29.5	8.0	37.5	8.0	29.5				
Max Q Clear Time (g_c+I1), s	7.3	36.6	5.8	29.6	3.7	10.6	6.2	21.9				
Green Ext Time (p_c), s	0.0	0.5	0.0	0.0	0.0	1.4	0.0	1.5				
Intersection Summary												
HCM 6th Ctrl Delay			43.0									
HCM 6th LOS			D									

Intersection

Intersection Delay, s/veh	39.5
Intersection LOS	E

Movement	EBL	EBT	EBR	WBL	WBT	WBR	NBL	NBT	NBR	SBL	SBT	SBR
Lane Configurations												
Traffic Vol, veh/h	86	366	54	95	272	60	26	101	88	117	181	75
Future Vol, veh/h	86	366	54	95	272	60	26	101	88	117	181	75
Peak Hour Factor	0.93	0.93	0.93	0.93	0.93	0.93	0.93	0.93	0.93	0.93	0.93	0.93
Heavy Vehicles, %	1	1	0	2	2	4	0	1	0	1	1	1
Mvmt Flow	92	394	58	102	292	65	28	109	95	126	195	81
Number of Lanes	1	1	0	1	1	0	1	1	0	1	1	0

Approach	EB	WB	NB	SB
Opposing Approach	WB	EB	SB	NB
Opposing Lanes	2	2	2	2
Conflicting Approach Left	SB	NB	EB	WB
Conflicting Lanes Left	2	2	2	2
Conflicting Approach Right	NB	SB	WB	EB
Conflicting Lanes Right	2	2	2	2
HCM Control Delay	66	33.1	19.2	22.6
HCM LOS	F	D	C	C

Lane	NBLn1	NBLn2	EBLn1	EBLn2	WBLn1	WBLn2	SBLn1	SBLn2
Vol Left, %	100%	0%	100%	0%	100%	0%	100%	0%
Vol Thru, %	0%	53%	0%	87%	0%	82%	0%	71%
Vol Right, %	0%	47%	0%	13%	0%	18%	0%	29%
Sign Control	Stop	Stop	Stop	Stop	Stop	Stop	Stop	Stop
Traffic Vol by Lane	26	189	86	420	95	332	117	256
LT Vol	26	0	86	0	95	0	117	0
Through Vol	0	101	0	366	0	272	0	181
RT Vol	0	88	0	54	0	60	0	75
Lane Flow Rate	28	203	92	452	102	357	126	275
Geometry Grp	7	7	7	7	7	7	7	7
Degree of Util (X)	0.074	0.494	0.225	1.02	0.251	0.813	0.32	0.644
Departure Headway (Hd)	9.778	8.931	8.742	8.131	9.001	8.35	9.31	8.575
Convergence, Y/N	Yes	Yes	Yes	Yes	Yes	Yes	Yes	Yes
Cap	368	406	413	452	401	436	389	424
Service Time	7.478	6.631	6.441	5.83	6.701	6.05	7.01	6.275
HCM Lane V/C Ratio	0.076	0.5	0.223	1	0.254	0.819	0.324	0.649
HCM Control Delay	13.3	20	14	76.6	14.7	38.4	16.3	25.5
HCM Lane LOS	B	C	B	F	B	E	C	D
HCM 95th-tile Q	0.2	2.7	0.9	13.6	1	7.5	1.4	4.4

HCM 6th Signalized Intersection Summary
 3: Wilsonville Rd/Stafford Rd & Boeckman Rd/Advance Rd

Frog Pond Crossing
 Existing PM + Project + Stage II



Movement	EBL	EBT	EBR	WBL	WBT	WBR	NBL	NBT	NBR	SBL	SBT	SBR
Lane Configurations												
Traffic Volume (veh/h)	292	67	98	52	67	18	57	229	53	22	479	313
Future Volume (veh/h)	292	67	98	52	67	18	57	229	53	22	479	313
Initial Q (Qb), veh	0	0	0	0	0	0	0	0	0	0	0	0
Ped-Bike Adj(A_pbT)	1.00		1.00	0.99		0.99	1.00		1.00	1.00		1.00
Parking Bus, Adj	1.00	1.00	1.00	1.00	1.00	1.00	1.00	1.00	1.00	1.00	1.00	1.00
Work Zone On Approach		No			No			No			No	
Adj Sat Flow, veh/h/ln	1885	1870	1900	1811	1870	1900	1870	1900	1841	1752	1900	1841
Adj Flow Rate, veh/h	307	71	19	55	71	6	60	241	48	23	504	305
Peak Hour Factor	0.95	0.95	0.95	0.95	0.95	0.95	0.95	0.95	0.95	0.95	0.95	0.95
Percent Heavy Veh, %	1	2	0	6	2	0	2	0	4	10	0	4
Cap, veh/h	449	387	332	247	117	10	194	767	153	542	533	322
Arrive On Green	0.18	0.21	0.21	0.04	0.07	0.07	0.04	0.50	0.50	0.02	0.48	0.48
Sat Flow, veh/h	1795	1870	1606	1725	1700	144	1781	1538	306	1668	1108	671
Grp Volume(v), veh/h	307	71	19	55	0	77	60	0	289	23	0	809
Grp Sat Flow(s),veh/h/ln	1795	1870	1606	1725	0	1843	1781	0	1845	1668	0	1779
Q Serve(g_s), s	11.4	2.4	0.7	2.2	0.0	3.1	1.3	0.0	7.1	0.5	0.0	33.0
Cycle Q Clear(g_c), s	11.4	2.4	0.7	2.2	0.0	3.1	1.3	0.0	7.1	0.5	0.0	33.0
Prop In Lane	1.00		1.00	1.00		0.08	1.00		0.17	1.00		0.38
Lane Grp Cap(c), veh/h	449	387	332	247	0	127	194	0	919	542	0	855
V/C Ratio(X)	0.68	0.18	0.06	0.22	0.00	0.61	0.31	0.00	0.31	0.04	0.00	0.95
Avail Cap(c_a), veh/h	450	638	548	272	0	399	220	0	920	596	0	887
HCM Platoon Ratio	1.00	1.00	1.00	1.00	1.00	1.00	1.00	1.00	1.00	1.00	1.00	1.00
Upstream Filter(I)	1.00	1.00	1.00	1.00	0.00	1.00	1.00	0.00	1.00	1.00	0.00	1.00
Uniform Delay (d), s/veh	24.6	24.9	24.2	31.4	0.0	34.5	17.0	0.0	11.4	9.8	0.0	18.8
Incr Delay (d2), s/veh	4.2	0.2	0.1	0.4	0.0	4.6	0.9	0.0	0.2	0.0	0.0	18.1
Initial Q Delay(d3),s/veh	0.0	0.0	0.0	0.0	0.0	0.0	0.0	0.0	0.0	0.0	0.0	0.0
%ile BackOfQ(50%),veh/ln	5.1	1.0	0.3	0.9	0.0	1.5	0.5	0.0	2.7	0.2	0.0	16.3
Unsig. Movement Delay, s/veh												
LnGrp Delay(d),s/veh	28.8	25.1	24.3	31.8	0.0	39.1	17.9	0.0	11.6	9.9	0.0	37.0
LnGrp LOS	C	C	C	C	A	D	B	A	B	A	A	D
Approach Vol, veh/h		397			132			349			832	
Approach Delay, s/veh		28.0			36.0			12.6			36.2	
Approach LOS		C			D			B			D	
Timer - Assigned Phs	1	2	3	4	5	6	7	8				
Phs Duration (G+Y+Rc), s	7.4	41.1	17.9	9.8	6.0	42.5	7.4	20.3				
Change Period (Y+Rc), s	4.5	4.5	4.5	4.5	4.5	4.5	4.5	4.5				
Max Green Setting (Gmax), s	4.0	38.0	13.5	16.5	4.0	38.0	4.0	26.0				
Max Q Clear Time (g_c+1), s	13.3	35.0	13.4	5.1	2.5	9.1	4.2	4.4				
Green Ext Time (p_c), s	0.0	1.6	0.0	0.2	0.0	1.8	0.0	0.3				

Intersection Summary

HCM 6th Ctrl Delay	29.5
HCM 6th LOS	C

Intersection

Int Delay, s/veh 531.9

Movement	EBL	EBT	WBT	WBR	SBL	SBR
Lane Configurations						
Traffic Vol, veh/h	185	530	636	313	181	286
Future Vol, veh/h	185	530	636	313	181	286
Conflicting Peds, #/hr	0	0	0	0	3	0
Sign Control	Free	Free	Free	Free	Stop	Stop
RT Channelized	-	None	-	None	-	None
Storage Length	175	-	-	-	0	-
Veh in Median Storage, #	-	0	0	-	0	-
Grade, %	-	0	0	-	0	-
Peak Hour Factor	84	84	84	84	84	84
Heavy Vehicles, %	4	1	1	3	1	0
Mvmt Flow	220	631	757	373	215	340

Major/Minor	Major1	Major2	Minor2
Conflicting Flow All	1130	0	0 2018 944
Stage 1	-	-	- 944 -
Stage 2	-	-	- 1074 -
Critical Hdwy	4.14	-	- 6.41 6.2
Critical Hdwy Stg 1	-	-	- 5.41 -
Critical Hdwy Stg 2	-	-	- 5.41 -
Follow-up Hdwy	2.236	-	- 3.509 3.3
Pot Cap-1 Maneuver	611	-	- ~ 65 ~ 321
Stage 1	-	-	- 380 -
Stage 2	-	-	- 329 -
Platoon blocked, %		-	-
Mov Cap-1 Maneuver	611	-	- ~ 42 ~ 321
Mov Cap-2 Maneuver	-	-	- ~ 42 -
Stage 1	-	-	- 243 -
Stage 2	-	-	- 329 -

Approach	EB	WB	SB
HCM Control Delay, s	3.7	0	\$ 2421.5
HCM LOS			F

Minor Lane/Major Mvmt	EBL	EBT	WBT	WBR	SBLn1
Capacity (veh/h)	611	-	-	-	90
HCM Lane V/C Ratio	0.36	-	-	-	6.177
HCM Control Delay (s)	14.2	-	-	-	\$ 2421.5
HCM Lane LOS	B	-	-	-	F
HCM 95th %tile Q(veh)	1.6	-	-	-	61.6

Notes

~: Volume exceeds capacity \$: Delay exceeds 300s +: Computation Not Defined *: All major volume in platoon

Intersection

Int Delay, s/veh 0.3

Movement EBL EBR NBL NBT SBT SBR

Lane Configurations							
Traffic Vol, veh/h	8	5	8	617	857	15	
Future Vol, veh/h	8	5	8	617	857	15	
Conflicting Peds, #/hr	0	0	0	0	0	0	
Sign Control	Stop	Stop	Free	Free	Free	Free	
RT Channelized	-	None	-	None	-	None	
Storage Length	0	-	-	-	-	-	
Veh in Median Storage, #	0	-	-	0	0	-	
Grade, %	0	-	-	0	0	-	
Peak Hour Factor	95	95	95	95	95	95	
Heavy Vehicles, %	0	0	0	1	2	0	
Mvmt Flow	8	5	8	649	902	16	

Major/Minor Minor2 Major1 Major2

Conflicting Flow All	1575	910	918	0	-	0
Stage 1	910	-	-	-	-	-
Stage 2	665	-	-	-	-	-
Critical Hdwy	6.4	6.2	4.1	-	-	-
Critical Hdwy Stg 1	5.4	-	-	-	-	-
Critical Hdwy Stg 2	5.4	-	-	-	-	-
Follow-up Hdwy	3.5	3.3	2.2	-	-	-
Pot Cap-1 Maneuver	122	336	752	-	-	-
Stage 1	396	-	-	-	-	-
Stage 2	515	-	-	-	-	-
Platoon blocked, %				-	-	-
Mov Cap-1 Maneuver	120	336	752	-	-	-
Mov Cap-2 Maneuver	120	-	-	-	-	-
Stage 1	389	-	-	-	-	-
Stage 2	515	-	-	-	-	-

Approach EB NB SB

HCM Control Delay, s	29.8	0.1	0
HCM LOS	D		

Minor Lane/Major Mvmt NBL NBT EBLn1 SBT SBR

Capacity (veh/h)	752	-	159	-	-
HCM Lane V/C Ratio	0.011	-	0.086	-	-
HCM Control Delay (s)	9.8	0	29.8	-	-
HCM Lane LOS	A	A	D	-	-
HCM 95th %tile Q(veh)	0	-	0.3	-	-

Synchro ID	Control Type	Intersection	Control Type	LOS	Delay	V/C Ratio
	1 Signal	Parkway Ave & Boeckman Rd	Signal	D	43.0	0.98
	3 Signal	Wilsonville Rd/Stafford Rd & Boeckman R	Signal	C	29.5	0.88

G. HCM REPORTS – EXISTING + PROJECT + STAGE II + MITIGATION

HCM 6th Signalized Intersection Summary
2: Canyon Creek Rd & Boeckman Rd

Frog Pond Crossing
Existing PM + Project + Stage II + Mitigation



Movement	EBL	EBT	EBR	WBL	WBT	WBR	NBL	NBT	NBR	SBL	SBT	SBR
Lane Configurations												
Traffic Volume (veh/h)	86	366	54	95	272	60	26	101	88	117	181	75
Future Volume (veh/h)	86	366	54	95	272	60	26	101	88	117	181	75
Initial Q (Qb), veh	0	0	0	0	0	0	0	0	0	0	0	0
Ped-Bike Adj(A_pbT)	1.00		0.97	1.00		0.97	0.99		0.98	0.99		0.97
Parking Bus, Adj	1.00	1.00	1.00	1.00	1.00	1.00	1.00	1.00	1.00	1.00	1.00	1.00
Work Zone On Approach		No			No			No			No	
Adj Sat Flow, veh/h/ln	1885	1885	1900	1870	1870	1841	1976	1885	1900	1885	1885	1885
Adj Flow Rate, veh/h	92	394	49	102	292	52	28	109	42	126	195	57
Peak Hour Factor	0.93	0.93	0.93	0.93	0.93	0.93	0.93	0.93	0.93	0.93	0.93	0.93
Percent Heavy Veh, %	1	1	0	2	2	4	0	1	0	1	1	1
Cap, veh/h	455	650	81	384	614	109	213	197	76	306	277	81
Arrive On Green	0.04	0.40	0.41	0.04	0.40	0.41	0.01	0.15	0.16	0.05	0.20	0.21
Sat Flow, veh/h	1795	1638	204	1781	1539	274	1882	1290	497	1795	1389	406
Grp Volume(v), veh/h	92	0	443	102	0	344	28	0	151	126	0	252
Grp Sat Flow(s),veh/h/ln	1795	0	1842	1781	0	1813	1882	0	1787	1795	0	1795
Q Serve(g_s), s	1.7	0.0	10.7	1.9	0.0	7.9	0.4	0.0	4.4	3.0	0.0	7.3
Cycle Q Clear(g_c), s	1.7	0.0	10.7	1.9	0.0	7.9	0.4	0.0	4.4	3.0	0.0	7.3
Prop In Lane	1.00		0.11	1.00		0.15	1.00		0.28	1.00		0.23
Lane Grp Cap(c), veh/h	455	0	731	384	0	724	213	0	273	306	0	358
V/C Ratio(X)	0.20	0.00	0.61	0.27	0.00	0.48	0.13	0.00	0.55	0.41	0.00	0.70
Avail Cap(c_a), veh/h	485	0	731	410	0	724	300	0	696	306	0	700
HCM Platoon Ratio	1.00	1.00	1.00	1.00	1.00	1.00	1.00	1.00	1.00	1.00	1.00	1.00
Upstream Filter(I)	1.00	0.00	1.00	1.00	0.00	1.00	1.00	0.00	1.00	1.00	0.00	1.00
Uniform Delay (d), s/veh	10.4	0.0	13.4	10.9	0.0	12.4	22.4	0.0	21.9	20.0	0.0	20.8
Incr Delay (d2), s/veh	0.2	0.0	3.7	0.4	0.0	2.2	0.3	0.0	1.7	0.9	0.0	2.5
Initial Q Delay(d3),s/veh	0.0	0.0	0.0	0.0	0.0	0.0	0.0	0.0	0.0	0.0	0.0	0.0
%ile BackOfQ(50%),veh/ln	0.6	0.0	4.5	0.7	0.0	3.2	0.3	0.0	1.8	1.4	0.0	3.0
Unsig. Movement Delay, s/veh												
LnGrp Delay(d),s/veh	10.6	0.0	17.1	11.3	0.0	14.7	22.7	0.0	23.6	20.9	0.0	23.3
LnGrp LOS	B	A	B	B	A	B	C	A	C	C	A	C
Approach Vol, veh/h		535			446			179				378
Approach Delay, s/veh		16.0			13.9			23.5				22.5
Approach LOS		B			B			C				C
Timer - Assigned Phs	1	2	3	4	5	6	7	8				
Phs Duration (G+Y+Rc), s	8.0	13.6	7.2	27.2	5.4	16.1	7.0	27.3				
Change Period (Y+Rc), s	4.0	4.5	4.0	4.5	4.0	4.5	4.0	4.5				
Max Green Setting (Gmax), s	4.0	22.3	4.0	22.7	4.0	22.3	4.0	22.7				
Max Q Clear Time (g_c+I1), s	5.0	6.4	3.9	12.7	2.4	9.3	3.7	9.9				
Green Ext Time (p_c), s	0.0	0.7	0.0	2.0	0.0	1.2	0.0	1.7				

Intersection Summary

HCM 6th Ctrl Delay	17.8
HCM 6th LOS	B

Synchro ID	Control Type	Intersection	Control Type	LOS	Delay	V/C Ratio
2	Signal	Canyon Creek Rd & Boeckman Rd	Signal	B	17.8	0.63

SITE LAYOUT

Site: [Wilsonville Frog Pond Crossing]

Site Category: -
Roundabout

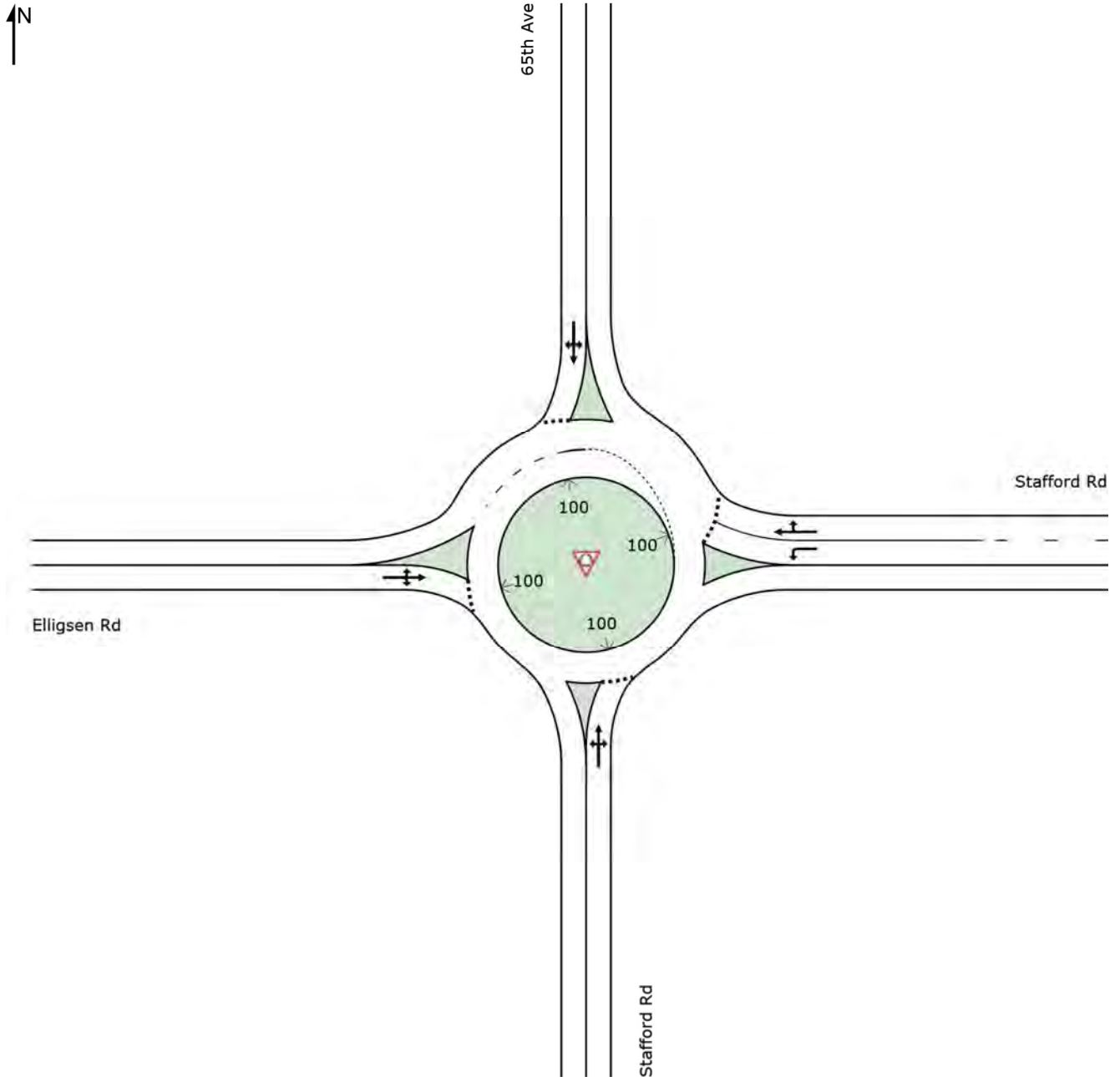

INPUT VOLUMES

Vehicles and pedestrians per 60 minutes

Site: [Wilsonville Frog Pond Crossing]

Site Category: -
Roundabout

Volume Display Method: Total and %

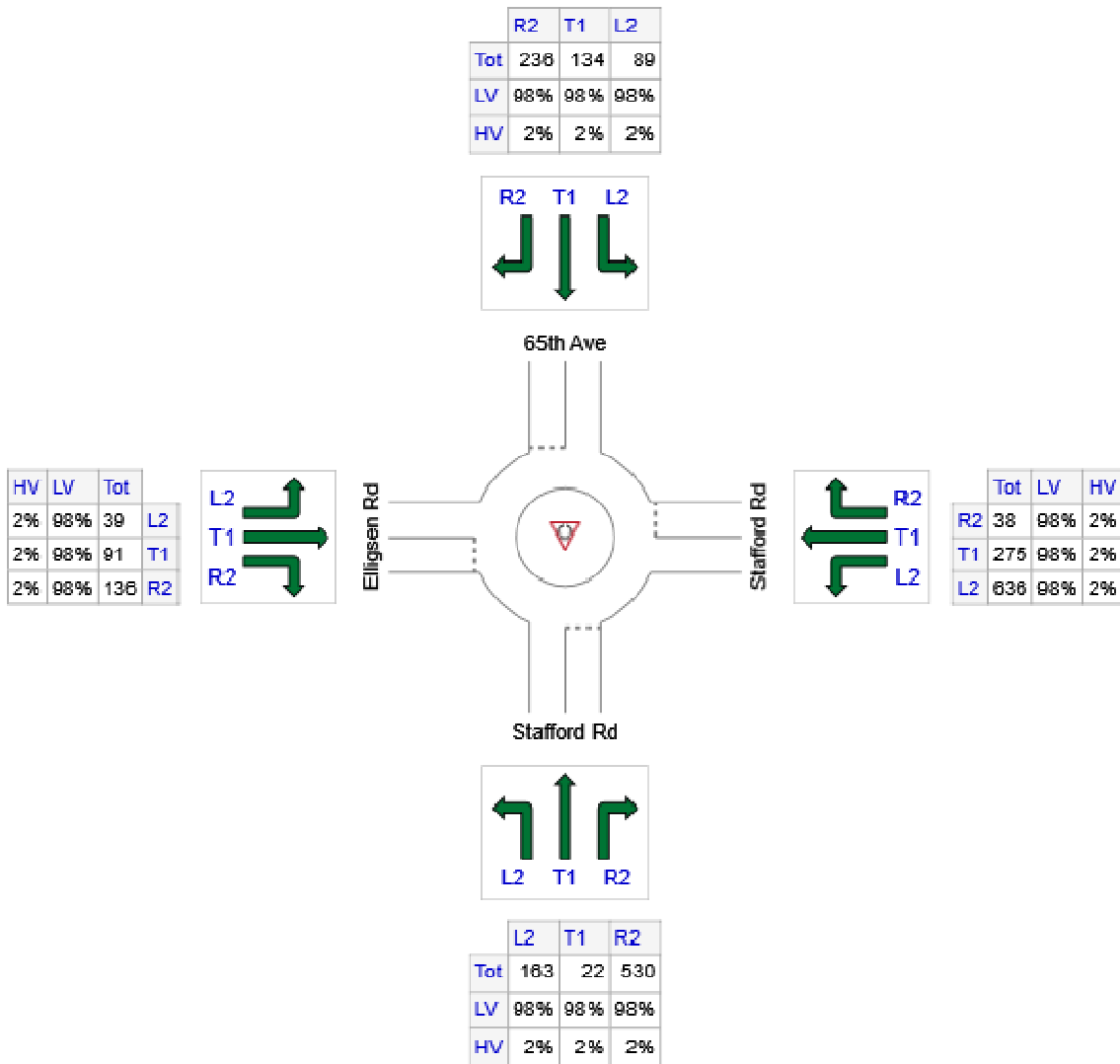

	All MCs	Light Vehicles (LV)	Heavy Vehicles (HV)
S: Stafford Rd	715	701	14
E: Stafford Rd	949	930	19
N: 65th Ave	459	450	9
W: Elligsen Rd	266	261	5
Total	2389	2341	48

MOVEMENT SUMMARY

 Site: [Wilsonville Frog Pond Crossing]

Site Category: -
Roundabout

Movement Performance - Vehicles												
Mov ID	Turn	Demand Total veh/h	Flows HV %	Deg. Satn v/c	Average Delay sec	Level of Service	95% Back of Queue Vehicles veh	Distance ft	Prop. Queued	Effective Stop Rate	Aver. No. Cycles	Average Speed mph
South: Stafford Rd												
3	L2	172	2.0	0.707	14.6	LOS B	11.6	294.2	0.77	0.81	1.17	30.1
8	T1	23	2.0	0.707	14.6	LOS B	11.6	294.2	0.77	0.81	1.17	30.0
18	R2	558	2.0	0.707	14.6	LOS B	11.6	294.2	0.77	0.81	1.17	29.3
Approach		753	2.0	0.707	14.6	LOS B	11.6	294.2	0.77	0.81	1.17	29.5
East: Stafford Rd												
1	L2	669	2.0	0.599	10.9	LOS B	5.4	137.0	0.61	0.53	0.72	30.1
6	T1	289	2.0	0.295	6.0	LOS A	1.4	35.9	0.42	0.30	0.42	34.7
16	R2	40	2.0	0.295	6.0	LOS A	1.4	35.9	0.42	0.30	0.42	33.6
Approach		999	2.0	0.599	9.3	LOS A	5.4	137.0	0.55	0.45	0.62	31.4
North: 65th Ave												
7	L2	94	2.0	0.925	50.8	LOS F	12.1	307.6	0.95	1.64	3.37	20.4
4	T1	141	2.0	0.925	50.8	LOS F	12.1	307.6	0.95	1.64	3.37	20.3
14	R2	248	2.0	0.925	50.8	LOS F	12.1	307.6	0.95	1.64	3.37	20.0
Approach		483	2.0	0.925	50.8	LOS F	12.1	307.6	0.95	1.64	3.37	20.2
West: Elligsen Rd												
5	L2	41	2.0	0.530	16.9	LOS C	3.1	79.2	0.79	0.93	1.25	29.4
2	T1	96	2.0	0.530	16.9	LOS C	3.1	79.2	0.79	0.93	1.25	29.4
12	R2	143	2.0	0.530	16.9	LOS C	3.1	79.2	0.79	0.93	1.25	28.6
Approach		280	2.0	0.530	16.9	LOS C	3.1	79.2	0.79	0.93	1.25	29.0
All Vehicles		2515	2.0	0.925	19.7	LOS C	12.1	307.6	0.72	0.84	1.38	27.7

Site Level of Service (LOS) Method: Delay & v/c (HCM 6). Site LOS Method is specified in the Parameter Settings dialog (Site tab).
Roundabout LOS Method: Same as Sign Control.

Vehicle movement LOS values are based on average delay and v/c ratio (degree of saturation) per movement.

LOS F will result if v/c > 1 irrespective of movement delay value (does not apply for approaches and intersection).

Intersection and Approach LOS values are based on average delay for all movements (v/c not used as specified in HCM 6).

Roundabout Capacity Model: US HCM 6.

HCM Delay Formula option is used. Control Delay does not include Geometric Delay since Exclude Geometric Delay option applies.

Gap-Acceptance Capacity: Traditional M1.

HV (%) values are calculated for All Movement Classes of All Heavy Vehicle Model Designation.

H. SITE PLAN

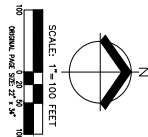

PRELIMINARY AERIAL PHOTOGRAPH PLAN
FROG POND CROSSING
VENTURE PROPERTIES, INC.
WILSONVILLE, OREGON

AKS ENGINEERING & FORESTRY, LLC
 12965 SW HERMAN RD, STE 100
 TUALATIN, OR 97062
 503.563.8151
 WWW.AKS-ENG.COM

AKS

ENGINEERING • SURVEYING • NATURAL RESOURCES
 FORESTRY • PLANNING • LANDSCAPE ARCHITECTURE

P-05

DATE: 07/14/2021
 DRAWN BY: JAB
 CHECKED BY: JAB



Exhibit F: SROZ Verification Report

Frog Pond Crossing Significant Resource Overlay Zone (SROZ) Map Verification

Date: June 2021

Prepared for: Venture Properties
4230 SW Galewood Street, Ste 100
Lake Oswego, OR 97035

Prepared by: AKS Engineering & Forestry, LLC
Stacey Reed, PWS, Senior Wetland Scientist
503-563-6151 | stacey@aks-eng.com

Site Information: 27227 SW Stafford Road
Wilsonville, Clackamas County, Oregon
Clackamas County Assessor's Map 3 1W 12D
Tax Lots 100, 300 and 302

AKS Job Number: 5252



12965 SW Herman Road, Suite 100
Tualatin, OR 97062
(503) 563-6151

Table of Contents

Introduction.....	1
Background Mapping and Site Information	1
Wetlands and Waters Mapping	2
Wetland Delineation.....	2
Wetlands	2
Adding Wetlands to SROZ	3
Report Preparer and Qualifications.....	4
Literature Cited and Referenced	5

Figures

- Figure 1:** USGS Vicinity Map
- Figure 2:** Tax Lot Map
- Figure 3:** NRCS Soils Map
- Figure 4:** National Wetlands Inventory (NWI) Map
- Figure 5:** PHS Frog Pond UGB Area Planning Map
- Figure 6:** Natural Resources Existing Conditions Map

Appendices

- Appendix A:** Approved Jurisdictional Determination from USACE NWP-2021-68
 - Appendix B:** Representative Site Photographs
 - Appendix C:** OFWAM Assessment for Water Quality and Hydrologic Control Functions
-

Introduction

AKS Engineering & Forestry, LLC (AKS) was contracted by Venture Properties to prepare a Significant Resource Overlay Zone (SROZ) Map Verification for the Frog Pond Crossing residential development project located at 27227 SW Stafford Road in Wilsonville, Clackamas County, Oregon. The project site consists of ax Lots 100, 300, and 302 of Clackamas County Assessor's Map 3 1W 12D, which is located at 27227 SW Stafford Road, Wilsonville, Clackamas County, Oregon (Figures 1 and 2). The project site is located within the Frog Pond West Neighborhood of the Frog Pond Plan Area and was added to the City of Wilsonville Urban Growth Boundary (UGB) in 2002.

The on-site boundary of one palustrine emergent wetland (referred to as PEM Wetland) was delineated in the study area. Wetland conditions extends slightly off-site to the north and to the east, draining into a roadside ditch along SW Stafford Road. The wetland and the portion of the roadside ditch adjacent to the wetland are likely to be determined jurisdictional to the Oregon Department of State Lands (DSL). The wetland delineation report is currently under review by DSL per File WD#2021-0285. The on-site wetland was determined to be non-jurisdictional to the U.S. Army Corp of Engineers (USACE).

The site is not included in the City's 2009 Significant Natural Resource Overlay Zone (SROZ) map and wetlands delineated on the project site do not meet any of the criteria listed under Section 4.139.10(.02) of the City of Wilsonville's (City) SROZ ordinance and are therefore not required to be added to the SROZ map as significant wetlands and do not require vegetated corridor buffers.

The project avoids wetland impacts for site development, but will require unavoidable permanent trenching through wetland to install a stormwater outfall into the ditch along Stafford Road. The wetland and ditch will likely be considered jurisdictional to DSL, requiring a removal-fill permit for removal and/or fill from within the wetland and ditch exceeding 50 cubic yards. The avoided wetland area will be set aside within Tract A.

This report documents PEM wetland delineated on the project site does not meet requirements listed under Section 4.139.10(.02)A-D and therefore should not be added to the SROZ maps.

Background Mapping and Site Information

The study area contains a house and detached barn located in the eastern portion of the study area, with remaining portions consisting of an open field used for horse grazing. The field is dominated by planted large sweet vernal grass (*Anthoxanthum odoratum*, FACU), field meadow-foxtail (*Alopecurus pratensis*, FAC), and bentgrass (*Agrostis* species, FAC) with scattered Himalayan blackberry (*Rubus armeniacus*, FAC) sprouting in the field and along the perimeter fence lines. Oregon white oak (*Quercus garryana*, FACU) and Ponderosa pine (*Pinus ponderosa*, FACU) trees are present along the northern and western study area boundaries.

Bonneville Power Administration (BPA) over-head power lines and easement extend through the eastern portion of the site. A BPA tower is present in wetland, in the eastern portion of the site.

Topography within the study area is generally flat with a subtle easterly slope towards wetland and SW Stafford Road. The current and historical land use consists of rural residential. Rural residential land use is currently present immediately adjacent to the site, with the Frog Pond single-family residential community under construction to the south of Frog Pond Lane.

The following soil units are mapped within the study area, according to the Natural Resources Conservation Service (NRCS) Clackamas County Area Soil Survey Map (Figure 3 in Appendix A):

- Aloha silt loam, (Unit 1A), 0 to 3 percent slopes—Non-hydric,
- Woodburn silt loam, (Unit 91B), 3 to 8 percent slopes—Non-hydric

Wetlands and Waters Mapping

Wilsonville DSL Approved Local Wetland and Riparian Inventory Maps: The project site is not within the City of Wilsonville’s 1998 Local Wetland or Riparian Corridor Inventory map boundaries.

National Wetland Inventory Map: According to the US Fish and Wildlife Service (USFWS) National Wetland Inventory (NWI) map, no wetlands are mapped in the project area (Figure 4).

City of Wilsonville Significant Resource Overlay Zone (SROZ) Map: The project site is located outside of the study area limits on the current SROZ map.

Frog Pond and Advance Road Urban Growth (UGB) Areas: According to Pacific Habitat Services (PHS) 2017 study for the Frog Pond and Advance Road UGB, a portion of wetland (identified as Wetland 9) is mapped in the northeast corner of the project site (Figure 5). Our study determined a larger polygon of wetland is present on the site.

Metro’s UGMFP Title 3 Water Quality Resource and Title 13 Habitat Conservation Area Maps: According to Metro’s mapping, no Title 3 or Title 13 resources are mapped on the site or immediately adjacent to the site.

Wetland Delineation

AKS delineated the boundary of one PEM wetland polygons on the project site. The boundaries of wetland delineated on the project site is shown on Figure 6, Natural Resources Existing Conditions Map. The wetland delineation report is currently under review at DSL per DSL File WD2021-0285. The Approved Non-Jurisdictional Determination Letter from the USACE is included in Appendix A (USACE File NWP-2021-68).

Wetlands

A palustrine emergent wetland (PEM) was delineated is in the northeastern portion of the site. The main hydrology source for the PEM wetland is a seasonally-high groundwater table. The wetland is situated on a slight slope where water flows through the wetland in one direction; therefore, the wetland belongs to the Slope hydrogeomorphic (HGM) classification. Wetland conditions extends off-site to the north and to the east, draining into a roadside ditch along Stafford Road. Seasonal outflow discharges from the roadside ditch via a culvert under SW Stafford Road to the east.

The on-site wetland was dominated by planted field meadow-foxtail (FAC), with lesser amounts of large sweet vernal grass (FACU) and bentgrass (FAC). Vegetation within the wetland is subject to regular mowing and occasional grazing. Generally, soils in the wetland are low chroma (chroma of 2 or less) displaying common distinct and prominent redoximorphic features, meeting hydric soil indicator F6 Redox Dark Surface. Some wetland plots contained a depleted matrix below the dark surface, meeting hydric soil indicator A11 as well. A groundwater table was documented within the surface 12-inches during our February 2021 site visit.

The wetland boundary was defined based on changes in landform from higher elevation, convex hillslope in upland to lower elevation, concave depression in the wetland. The change in landform coincided with a change in the vegetation community from lesser amounts of sweet vernal grass in wetland to higher percentage of sweet vernal grass in upland. The upland lacked hydric soil indicators.

Adding Wetlands to SROZ

The PEM wetland delineated on the project site is not mapped on the City's SROZ; however, the wetland does not meet any of the criteria listed under Section 4.139.10(.02)A-D of Wilsonville's SROZ ordinance:

Wilsonville Development Code

Section 4.139.10 Development Review Board (DRB) Process

(.02) Adding Wetlands. Except for water quality or storm water detention facilities, the City shall initiate amendments to the Significant Resource Overlay Zone maps to add wetlands when the City receives significant evidence that a wetland meets any one of the following criteria:

A. The wetland is fed by surface flows, sheet flows or precipitation, and has evidence of flooding during the growing season, and has 60 percent or greater vegetated cover, and is over one-half acre in size; or the wetland qualifies as having intact water quality function under the 1996 Oregon Freshwater Wetland Assessment Methodology; or

Response: Wetland on the site totals 1.48 acres in size. The wetland is primarily fed by subsurface lateral flow and is not fed by surface or sheet flows. The wetland does not flood during the growing season; it is only seasonally saturated. There was no evidence of inundation (no algal matting, unvegetated bare areas, or soil cracking) during our early springtime site visit (February 2021). Under the 1996 Oregon Freshwater Assessment Methodology (OFWAM), the wetland does not have an intact water quality control function (OFWAM worksheets included in Appendix C).

B. The wetland is in the Metro Title 3 Flood Management Area as corrected by the most current FEMA Flood Insurance Rate Maps, and has evidence of flooding during the growing season, and is five acres or more in size, and has a restricted outlet or no outlet; or the wetland qualifies as having intact hydrologic control function under the 1996 Oregon Freshwater Wetland Assessment Methodology; or

Response: Wetland delineated on the site is not mapped within a current Federal Emergency Management Agency (FEMA) Flood Management Area. According to OFWAM, the wetland does not have an intact hydrologic control function (see OFWAM worksheets included in Appendix C). There was no evidence of flooding during the growing season, the wetland area is less than 5 acres in size, and lacks an outlet to waters.

C. The wetland or a portion of the wetland is within a horizontal distance of less than one-fourth mile from a water body which meets the Department of Environmental Quality definition of water quality limited water body in OAR Chapter 340, Division 41 (1996).

Response: Wetland on the project site is located greater than ¼-mile from an Oregon Department of Environmental Quality (DEQ) water-quality limited listed water body. The Willamette River is the closest water-quality limited water body, which is located over 1 mile from the project site.

D. Created or restored wetlands that meet the requirements of Section 4.139.10(.02) shall be added to the Significant Resource Overlay Zone. [Added by Ord. # 674 11/16/09]

Response: Wetland on the project site was not created or restored under requirements of Section 4.139.10 (.02) of City's SROZ ordinance.

Since the PEM wetland delineated on the site does not meet any of the above criteria, it is considered to be locally non-significant and do not require vegetated corridor or Impact Area setbacks.

Report Preparer and Qualifications



Stacey Reed, PWS
Senior Wetland Scientist
Fieldwork and Report Preparation

Stacey Reed is a certified Professional Wetland Scientist (PWS) with more than 20 years of experience delineating wetlands and waters, conducting wetland and stream function and value assessments and prepare natural resource assessments throughout Oregon.

Literature Cited and Referenced

- Adams, P.R. 2001. *Guidebook for Hydrogeomorphic (HGM)-based Assessment of Oregon Wetland and Riparian Sites: Statewide Classification and Profiles*. Salem (OR): Oregon Division of State Lands. Available at: http://www.oregon.gov/dsl/WW/Documents/hydro_guide_class.pdf. [Accessed August 2019].
- Cowardin, L.M. 1979. *Classification of Wetland and Deepwater Habitats of the United States*. Jamestown (ND): Northern Prairie Wildlife Research Center, US Fish and Wildlife Service.
- Natural Resources Conservation Service (NRCS). 2006. *Hydric Soils List: Clackamas County, Oregon*. Washington (DC): US Department of Agriculture.
- Natural Resources Conservation Service (NRCS). 2014a. *Official soil series descriptions*. Washington (DC): US Department of Agriculture. Available at: http://www.nrcs.usda.gov/wps/portal/nrcs/detailfull/soils/home/?cid=nrcs142p2_053587. [Accessed August 2019].
- Natural Resources Conservation Service (NRCS). 2014b. *Web soil survey*. Washington (DC): US Department of Agriculture. Available at: <http://websoilsurvey.nrcs.usda.gov/app/>. [Accessed August 2019].
- Oregon Map. 2019. Clackamas County Assessor's Map 3 1 W 12D. Oregon: State of Oregon. Available at: <http://www.ormap.net/>. [Accessed August 2019].
- Roth, E.M., R.D. Olsen, P.L. Snow, and R.R. Sumner. April 1996. *Oregon Freshwater Wetland Assessment Methodology*, Ed. By S.G. McCannell. Oregon Division of State Lands. Salem. OR.
- Wakeley, J.S., R.W. Lichvar, and C.V. Noble, eds. 2010. *Regional Supplement to the Corps of Engineers Wetland Delineation Manual: Western Mountains, Valleys, and Coast Region (Version 2.0)*. ERDC/EL TR-10-3. Vicksburg (MS): US Army Engineer Research and Development Center, US Army Corps of Engineers.
- Wilsonville. 2018. *January 2015 Development Code (as amended through October 2018)*. Wilsonville (OR): City of Wilsonville. Available at: <https://www.ci.wilsonville.or.us/planning/page/development-code> [Accessed January 2020].

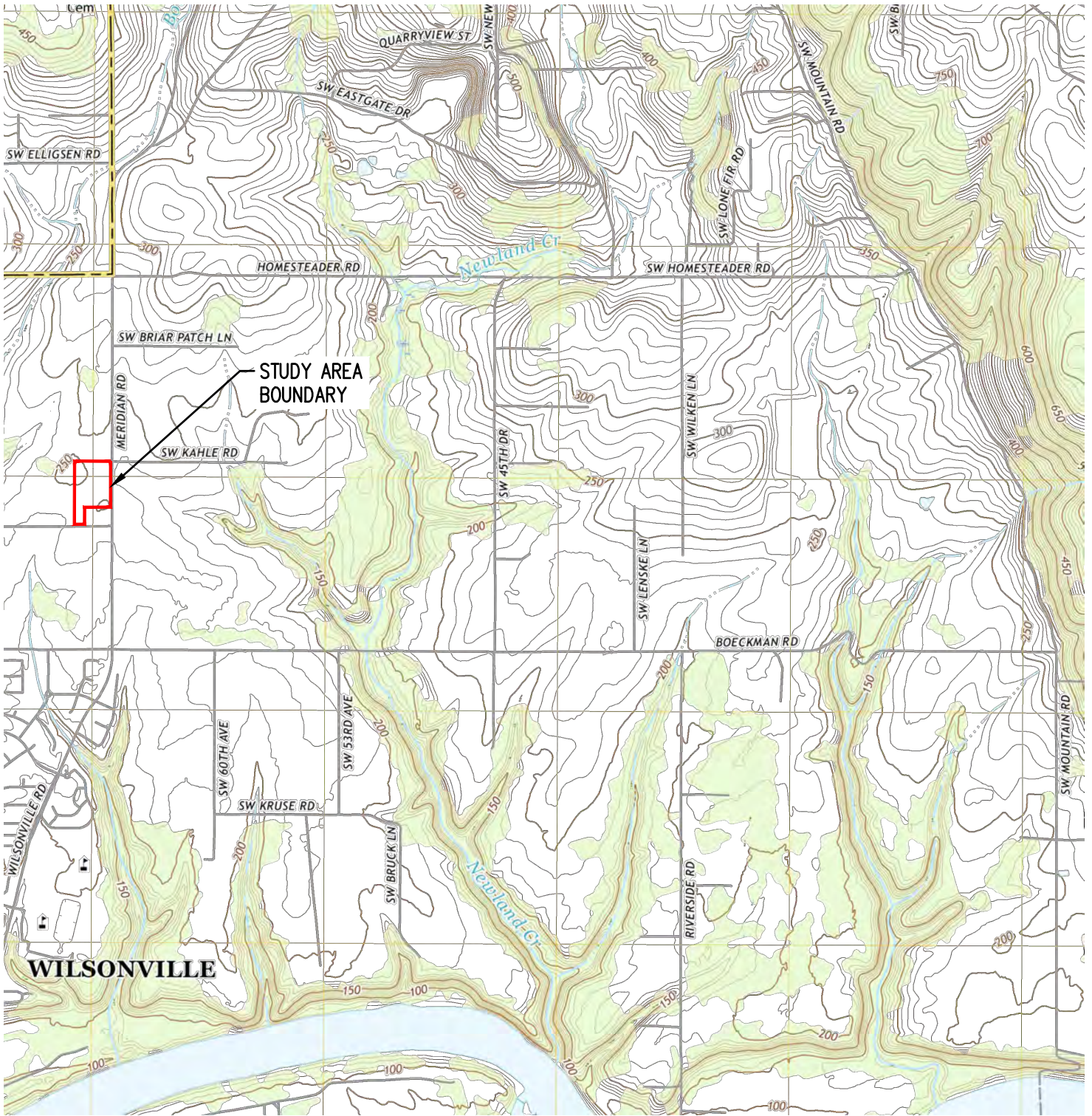

USGS 7.5' TOPOGRAPHIC SERIES
 QUADRANGLE: CANBY, OR (2020)

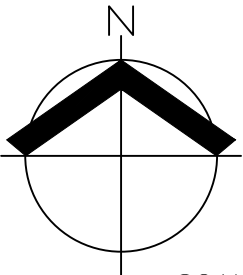

SCALE: 1" = 2000 FEET

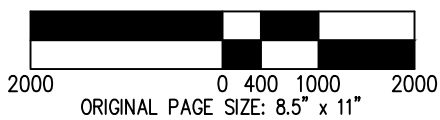

DATE: 06/29/2021

**USGS VICINITY MAP
 FROG POND CROSSING SROZ MAP VERIFICATION**

**FIGURE
 1**

AKS ENGINEERING & FORESTRY, LLC
 12965 SW HERMAN RD, STE 100
 TUALATIN, OR 97062
 503.563.6151 WWW.AKS-ENG.COM



DRWN: SKT
 CHKD: SAR
 AKS JOB:
 5252

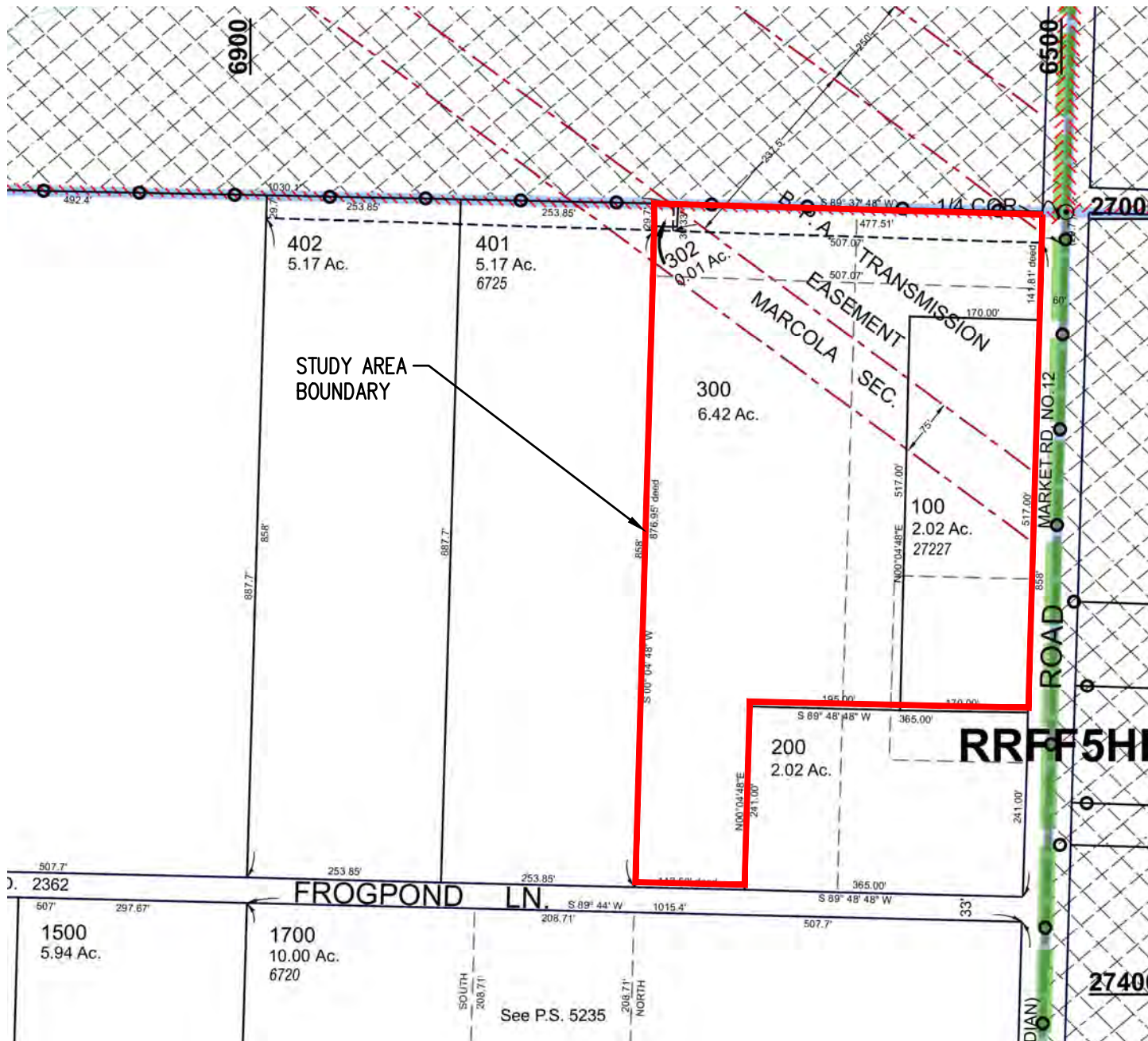

CLACKAMAS COUNTY
 TAX LOTS 100, 300, AND 302
 TAX MAP 3S 1W 12D

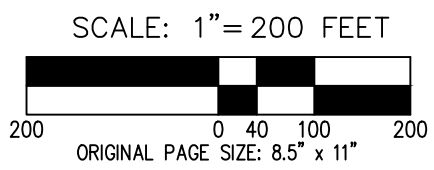
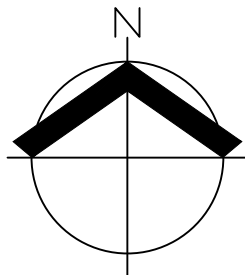

DATE: 06/29/2021

TAX MAP (MAP 3S 1W 12D) FROG POND CROSSING SROZ MAP VERIFICATION		FIGURE 2
AKS ENGINEERING & FORESTRY, LLC 12965 SW HERMAN RD, STE 100 TUALATIN, OR 97062 503.563.6151 WWW.AKS-ENG.COM		DRWN: SKT CHKD: SAR AKS JOB: 5252





MAP UNIT SYMBOL	MAP UNIT NAME
1A	ALOHA SILT LOAM, 0% TO 3% SLOPES; NON-HYDRIC
91B	WOODBURN SILT LOAM, 3% TO 8% SLOPES; NON-HYDRIC

NRCS WEB SOIL SURVEY FOR
CLACKAMAS COUNTY

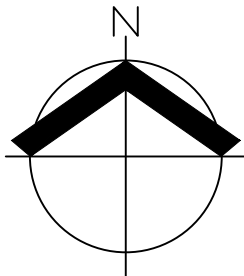

SCALE: 1" = 200 FEET

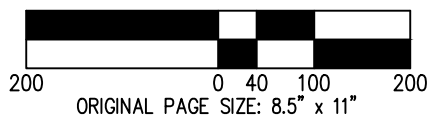

DATE: 06/29/2021

NRCS SOIL SURVEY MAP FROG POND CROSSING SROZ MAP VERIFICATION		FIGURE 3
AKS ENGINEERING & FORESTRY, LLC 12965 SW HERMAN RD, STE 100 TUALATIN, OR 97062 503.563.6151 WWW.AKS-ENG.COM		DRWN: SKT CHKD: SAR AKS JOB: 5252





Wetlands



Estuarine and Marine Deepwater



Estuarine and Marine Wetland



Freshwater Emergent Wetland



Freshwater Forested/Shrub Wetland



Freshwater Pond



Lake



Other



Riverine

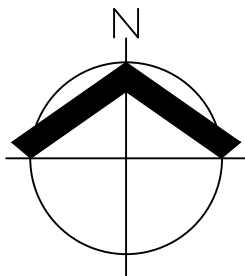

US FISH & WILDLIFE SERVICE
NATIONAL WETLANDS INVENTORY (2017)

DATE: 06/29/2021

SCALE: 1" = 300 FEET

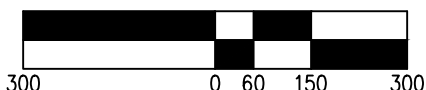

ORIGINAL PAGE SIZE: 8.5" x 11"

**NATIONAL WETLANDS INVENTORY MAP
FROG POND CROSSING SROZ MAP VERIFICATION**

FIGURE
4

AKS ENGINEERING & FORESTRY, LLC
12965 SW HERMAN RD, STE 100
TUALATIN, OR 97062
503.563.6151 WWW.AKS-ENG.COM



DRWN: SKT
CHKD: SAR
AKS JOB:
5252

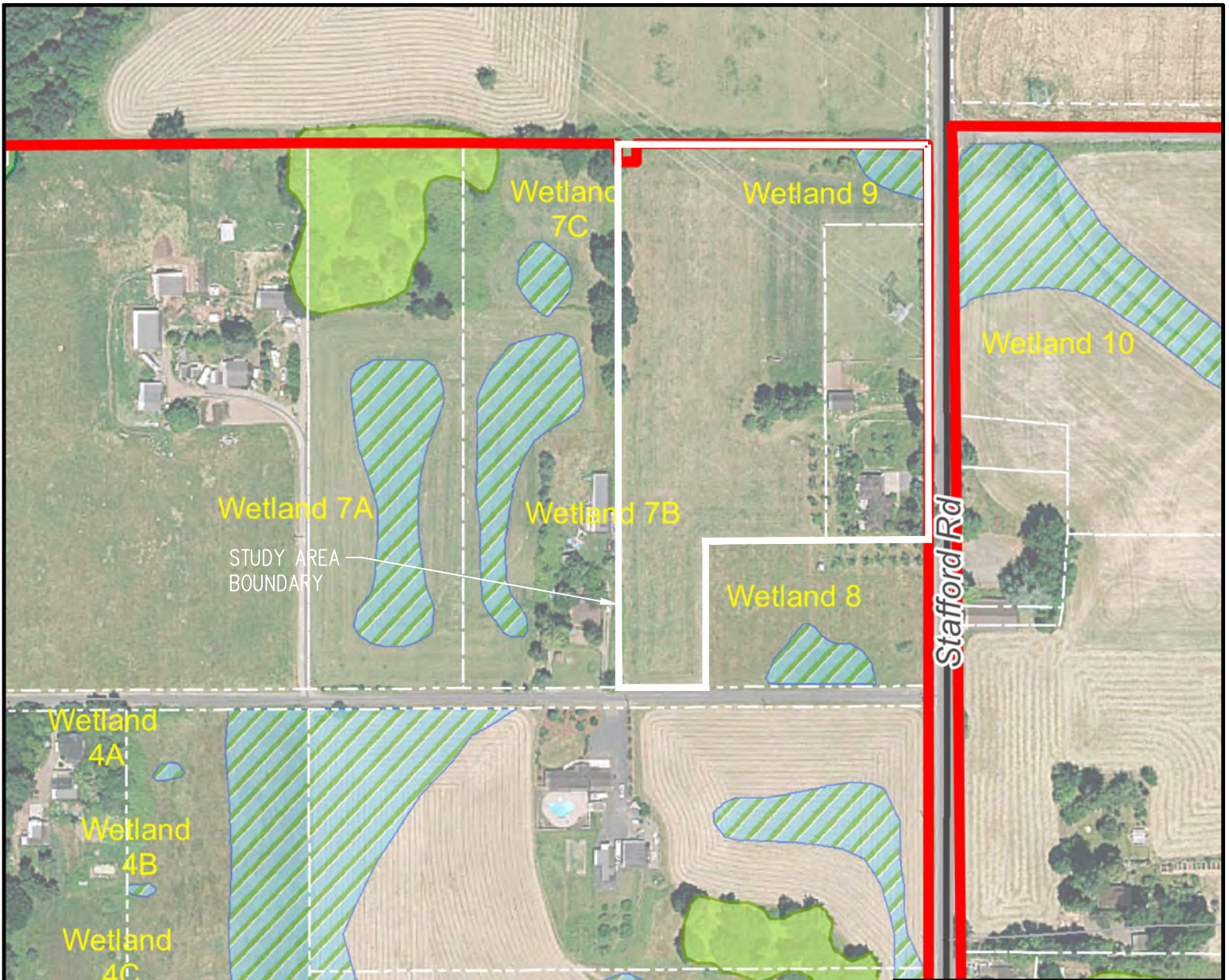

PACIFIC HABITAT SERVICES
 FROG POND AND ADVANCE ROAD URBAN GROWTH
 AREAS (2014)

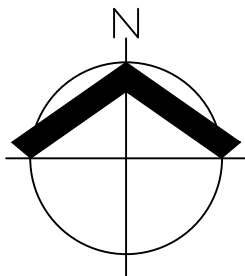
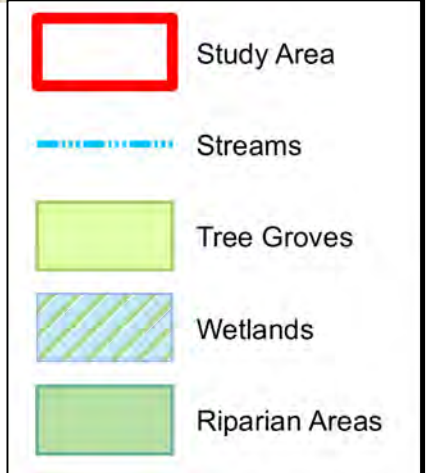

SCALE: 1" = 250 FEET

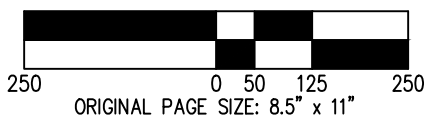

DATE: 06/29/2021

NATURAL RESOURCE INVENTORY MAP FROG POND CROSSING SROZ MAP VERIFICATION		FIGURE 5
AKS ENGINEERING & FORESTRY, LLC 12965 SW HERMAN RD, STE 100 TUALATIN, OR 97062 503.563.6151 WWW.AKS-ENG.COM		DRWN: SKT CHKD: SAR AKS JOB: 5252



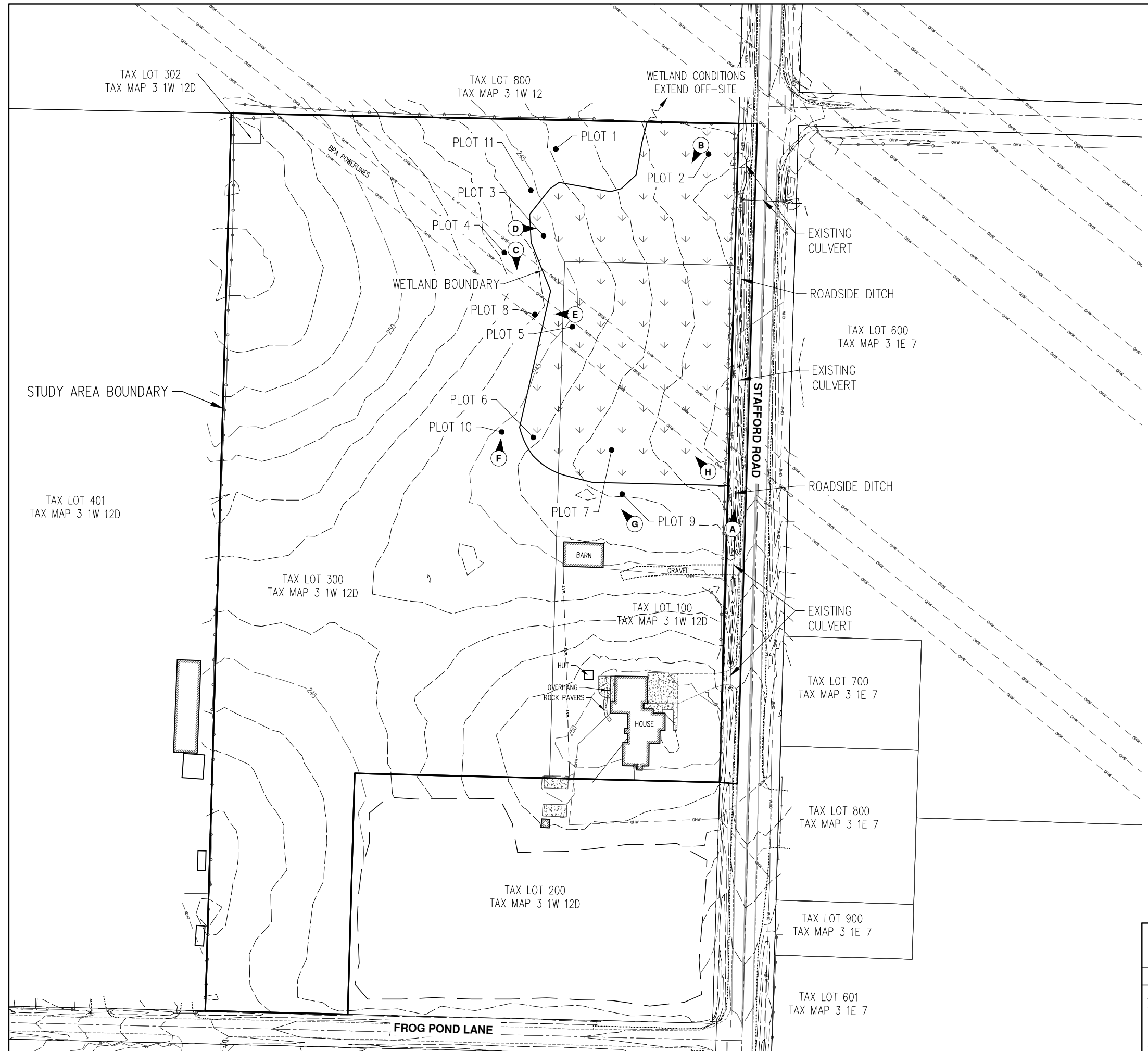

- LEGEND**
- SLOPE/PEM WETLAND:
64,350 SF± (1.48 ACRES±)
 - ROADSIDE DITCH ADJACENT TO WETLAND:
698 SF± / 285 LF± (0.02 ACRES±)
 - ROADSIDE DITCH: 158 LF±
 - PHOTO LOCATION & ORIENTATION

WETLAND BOUNDARY SHOWN WAS DELINEATED BY AKS ENGINEERING & FORESTRY, LLC (AKS) ON FEBRUARY 24, 2021 AND WAS LOCATED USING A TRIMBLE GEO 7X HANDHELD GPS RECEIVER WITH SUB-METER ACCURACY.

1-FOOT INTERVAL CONTOURS, EXISTING CONDITIONS, AND STUDY AREA DERIVED FROM AKS PROFESSIONAL LAND SURVEY.

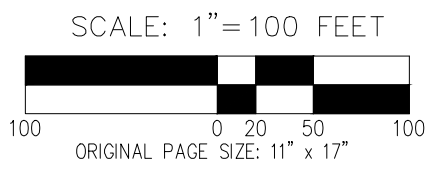
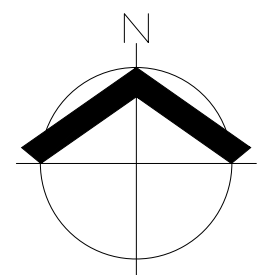

DATE: 06/29/2021

WETLAND DELINEATION MAP	FIGURE
FROG POND CROSSING SROZ MAP VERIFICATION	5
AKS ENGINEERING & FORESTRY, LLC 12965 SW HERMAN RD, STE 100 TUALATIN, OR 97062 503.563.6151 WWW.AKS-ENG.COM	DRWN: SKT CHKD: SAR AKS JOB: 5252



Appendix A:
USACE Approved Jurisdictional Determination NWP-
2021-68



DEPARTMENT OF THE ARMY
U.S. ARMY CORPS OF ENGINEERS, PORTLAND DISTRICT
P.O. BOX 2946
PORTLAND, OR 97208-2946

May 17, 2021

Regulatory Branch
Corps No. NWP-2021-68

Ms. Stacey Reed
AKS Engineering & Forestry, LLC
12965 SW Herman Road, Suite 100
Tualatin, Oregon 97062
staceyr@aks-eng.com

Dear Ms. Reed:

The U.S. Army Corps of Engineers (Corps) received your request for an Approved Jurisdictional Determination (AJD) of the waters or water features, including wetlands, within the review area as shown on the enclosed drawings (Enclosure 1). The Review Area is located at 27227 SW Stafford Road Wilsonville, Clatsop County, Oregon at Latitude/Longitude: 45.323236°, -122.744111°. Other waters or water features, including wetlands, that may occur on this property or on adjacent properties outside the review area are not the subject of this determination.

The Corps has determined the PEM wetland is not a water of the U.S. The enclosed *Approved Jurisdictional Determination Form (Interim)* (Enclosure 2) provides the basis for jurisdiction. A copy of the AJD Form can also be found on our website at <http://www.nwp.usace.army.mil/Missions/Regulatory/Appeals/>.

The Corps has determined there are no waters of the U.S. within the review area. The enclosed drawings (Enclosure 1) identify the review area for this determination. The enclosed *Approved Jurisdictional Determination Form (Interim)* (Enclosure 2) provides the basis for our determination. A copy of the AJD Form can also be found on our website at <http://www.nwp.usace.army.mil/Missions/Regulatory/Appeals/>.

If you object to the enclosed AJD, you may request an administrative appeal under 33 CFR Part 331 as described in the enclosed *Notification of Administrative Appeal Options and Process and Request for Appeal (RFA)* form (Enclosure 3). To appeal this AJD, you must submit a completed *RFA* form to the Corps Northwestern Division (NWD) office at the address listed on the form. In order for the request for appeal to be accepted, the Corps must determine that the form is complete, that the request meets the criteria for appeal under 33 CFR Part 331.5, and the form must also be received by the NWD office within 60 days from the date on the form. It is not necessary to submit the form to the NWD office if you do not object to the enclosed AJD.

The delineation included herein has been conducted to identify the location and extent of the aquatic resource boundaries and/or the jurisdictional status of aquatic resources for purposes of the Clean Water Act for the particular site identified in this request. This delineation and/or jurisdictional determination may not be valid for the Wetland Conservation Provisions of the Food Security Act of 1985, as amended. If you or your tenant are U.S. Department of Agriculture (USDA) program participants, or anticipate participation in USDA programs, you should discuss the applicability of a certified wetland determination with the local USDA service center, prior to starting work.

This AJD is valid for a period of five years from the date of this letter unless new information warrants revisions of the determination.

We would like to hear about your experience working with the Portland District, Regulatory Branch. Please complete a customer service survey form at the following address: <https://regulatory.ops.usace.army.mil/customer-service-survey/>.

If you have any questions regarding our Regulatory Program or permit requirements for work in waters of the U.S., please contact Mr. Brad Johnson by telephone at (503) 808-4383 or email at Brad.A.Johnson2@usace.army.mil.

Sincerely,

For: William D. Abadie
Chief, Regulatory Branch

Enclosures

cc with drawings:

Oregon Department of State Lands (Justin Russel, Justin.Russell@state.or.us)

Oregon Department of Environmental Quality (401applications@deq.state.or.us)

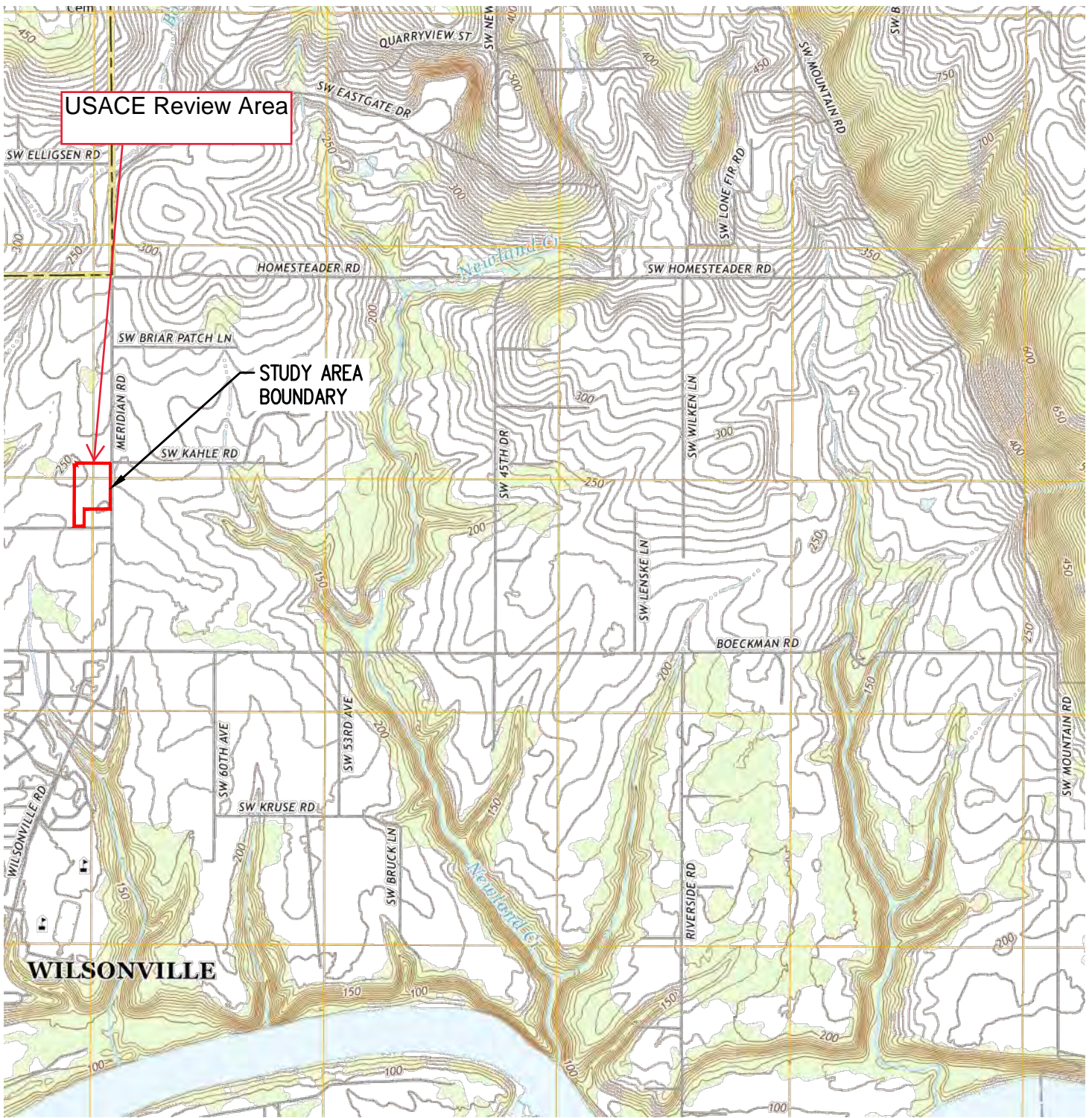

USACE Review Area

STUDY AREA BOUNDARY

WILSONVILLE

USGS 7.5' TOPOGRAPHIC SERIES
 QUADRANGLE: CANBY, OR (2020)

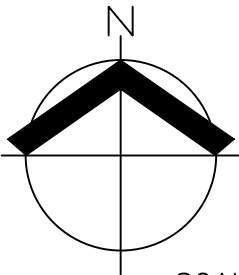

SCALE: 1" = 2000 FEET

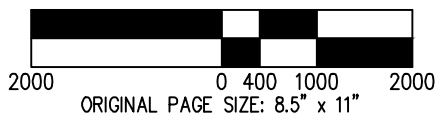

DATE: 01/28/2021

USGS VICINITY MAP FROG POND LANE USACE AJD MEMO		FIGURE 1
AKS ENGINEERING & FORESTRY, LLC 12965 SW HERMAN RD, STE 100 TUALATIN, OR 97062 503.563.6151 WWW.AKS-ENG.COM		DRWN: ANF CHKD: SKT AKS JOB: 5252



USACE Review Area



MAP UNIT SYMBOL	MAP UNIT NAME
1A	ALOHA SILT LOAM, 0% TO 3% SLOPES; NON-HYDRIC
91B	WOODBURN SILT LOAM, 3% TO 8% SLOPES; NON-HYDRIC

NRCS WEB SOIL SURVEY FOR
WASHINGTON COUNTY

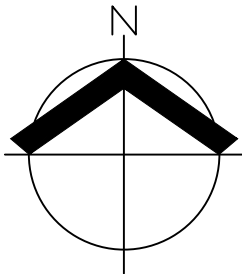

SCALE: 1" = 200 FEET

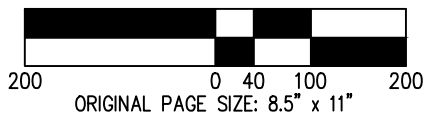

DATE: 01/28/2021

NRCS SOIL SURVEY MAP FROG POND LANE USACE AJD MEMO		FIGURE 3
AKS ENGINEERING & FORESTRY, LLC 12965 SW HERMAN RD, STE 100 TUALATIN, OR 97062 503.563.6151 WWW.AKS-ENG.COM		DRWN: ANF CHKD: SKT AKS JOB: 5252



GOOGLE EARTH AERIAL IMAGERY
JULY, 2019

USACE Review Area

STUDY AREA
BOUNDARY

PEM Wetland
(b)(1) Non-water of the United
States

WETLAND BOUNDARY

TAX LOT 402
TAX MAP 3 1W 12D

TAX LOT 401
TAX MAP 3 1W 12D

TAX LOT 300
TAX MAP 3 1W 12D

TAX LOT 100
TAX MAP 3 1W 12D

TAX LOT 700
TAX MAP 3 1E 7

TAX LOT 800
TAX MAP 3 1E 7

TAX LOT 900
TAX MAP 3 1E 7

TAX LOT 601
TAX MAP 3 1E 7

TAX LOT 200
TAX MAP 3 1W 12D

TAX LOT 302
TAX MAP 3 1W 12D

TAX LOT 800
TAX MAP 3 1W 12

TAX LOT 600
TAX MAP 3 1E 7

PLOT 1

PLOT 4

PLOT 2

PLOT 5

PLOT 3

PLOT 6

PLOT 7

PLOT 13

PLOT 10

PLOT 12

PLOT 11

PLOT 8

PLOT 9

STAFFORD ROAD

FROG POND LANE

LEGEND
PEM WETLAND:
58,569 SF± (1.34 ACRES±)

WETLAND BOUNDARY SHOWN WAS DELINEATED BY AKS
ENGINEERING & FORESTRY, LLC ON 04/20/2020 AND WAS
LOCATED USING A TRIMBLE GEO 7X HANDHELD GPS RECIEVER
WITH SUB-METER ACCURACY.

1-FOOT INTERVAL CONTOURS ARE DERIVED FROM LIDAR DATA.

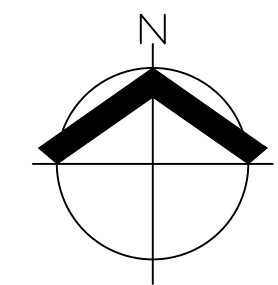

SCALE: 1" = 100 FEET

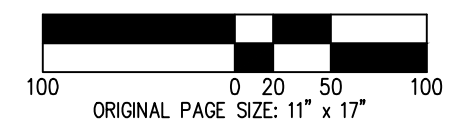

DATE: 2/02/2021

WETLAND DELINEATION MAP		FIGURE
FROG POND LANE		5
AKS ENGINEERING & FORESTRY, LLC 12965 SW HERMAN RD, STE 100 TUALATIN, OR 97062 503.563.6151 WWW.AKS-ENG.COM		DRWN: SKT CHKD: SAR AKS JOB: 5252



Appendix B: Representative Site Photographs



Photo A. View north of roadside ditch along Stafford Road.



Photo B. View southwest from Plot 2 within the lowest portion of the PEM wetland.



Photo C. View south from upland Plot 4 of open field.



Photo D. View east towards the PEM wetland and Plot 3.



Photo E. View west of upland Plot 8 from wetland Plot 5.



Photo F. View north at upland Plot 10.



Photo G. View northwest of Plot 9 in garden area.



Photo H. View northwest of PEM Wetland.

Appendix C: OFWAM Assessment for Water Quality and Hydrologic Control Functions



Frog Pond Crossing - PEM wetland

Water quality (pollutant removal)

Sediment trapping

During periods of heavy rainfall, water runoff may cause erosion and increase solids suspended in receiving surface waters. The excess sediment entering water systems can damage aquatic ecosystems. For example, sediment accumulation in stream bottoms can smother spawning areas and kill aquatic insect larvae. It can also reduce the storage capacity of downstream water supply reservoirs.

Wetlands perform an important function by trapping sediment from waters that pass through them. As water flows through wetlands, it is slowed by vegetation, and sediment settles to the bottom before the water moves farther downstream. As much as 90% of the solids suspended in the water may be removed as the water moves through wetlands, resulting in cleaner water entering streams, rivers, lakes and estuaries.

Nutrient attenuation

Nitrogen and phosphorus are the two nutrients most often associated with water pollution. They are also main ingredients of fertilizers used on agricultural fields and lawns, and both are found in high concentrations in discharges from sewage treatment plants and livestock operations. Excessive amounts of nitrogen and phosphorus in lakes and slow-moving streams can cause algal blooms and subsequent oxygen deficiencies, which may kill fish and reduce water quality. The processes that occur as a result of excess nutrients are lumped together under the term "eutrophication." Within limits, wetlands can reduce nutrient levels so that the effects of eutrophication on downstream areas are prevented or reduced. This index considers only point and non-point pollutant sources that are due to land uses in the watershed.

Assessment questions

Question 1

What is the wetland's primary source of water?

a. Surface flow, including streams and ditches.

b. Precipitation or sheet flow.

Directions

See question 36 in the Wetland Characterization.

c. Groundwater, including seeps and springs.

Rationale

Wetlands bordering a perennial or intermittent stream or lake are areas into which floodwaters spread during periods of high runoff, enabling the wetlands to remove pollutants.

Notes

Question 2

Is there evidence of flooding or ponding during a portion of the growing season?

- a. Yes.
- b. Unable to determine or not applicable.
- c. No.

Directions

See question 37 in the Wetland Characterization.

Rationale

Water level fluctuation in the wetland indicates the ability to retain water. Impounded or standing water acts as a sediment trap because it greatly slows the flow of the incoming water, allowing suspended solids to settle out. Additionally, the slower velocity increases the contact time of the water with vegetation, resulting in uptake of nutrients by the vegetation. These actions function to reduce pollutant loads.

Question 3

What is the degree of wetland vegetation cover?

- a. High (greater than 60%).
- b. Moderate (approximately 60%).
- c. Low (less than 60%).

Directions

See question 21 in the Wetland Characterization. Add the lower end of the ranges for forest, scrub-shrub and emergent vegetation to get the result. If the result is 60% or more, answer "high." If the result is 60%, answer "moderate." Answer "low" for other results.

Rationale

The more dense the vegetation, the greater the wetland's ability to take up nutrients. A dense stand of persistent emergent plants (such as cattail and rush) along with floating and submerged aquatics would tend to provide maximum nutrient uptake during the growing season. Wooded and scrub-shrub wetlands remove nutrients mainly through settling of suspended solids in runoff and flood waters.

Question 4

What is the wetland's area in acres?

Directions

See questions 17 and 27 in the Wetland Characterization.

- a. More than 5 acres.
- b. Between 0.5 acres and 5 acres; or wetland area is less than 0.5 acres, and the wetland is connected to other wetlands within a 3-mile radius by a perennial or intermittent stream, irrigation or drainage ditch, canal or lake.
- c. Less than 0.5 acres, and the wetland is not connected to other wetlands within a 3-mile radius by a perennial or intermittent stream, irrigation or drainage ditch, canal or lake.

Rationale

The larger the wetland, the greater its capacity and ability to filter pollutants. Small wetlands connected by surface water act as a series of filters and thus function similarly to a larger wetland.

Question 5

What is the dominant, existing land use within 500 feet of the wetland's edge?

- a. Developed uses.
- b. Agriculture.
- c. Exclusive Forest Use or Open Space.

Directions

Refer to the directions for question 8 of the wildlife habitat assessment questions.

Rationale

Urbanized areas have more impervious surface areas and concentrate pollution sources. Wetlands in urban areas are important for filtering the runoff water before it enters a stream.

Notes

Question 6

What is the water quality condition of stream reaches in the watershed upstream of the wetland or adjacent to the wetland?

Directions

See questions 7 and 8 in the Wetland Characterization. If both "a" and "b" apply, choose "a."

- a. One or more upstream or adjacent reaches are listed as *water quality limited* or in *severe* water quality condition for nonpoint source pollutants.
- b. One or more upstream or adjacent reaches are listed in *moderate* water quality condition for nonpoint source pollutants.
- c. No upstream or adjacent reaches are listed as *water quality limited*, and all upstream or adjacent reaches are listed as *no problem* (or no data available) for nonpoint source pollutants.

Notes

Rationale

A watershed with upstream pollutant loading sources needs wetlands to reduce pollutant levels in water before it is delivered downstream.

Water quality: assessment criteria

A wetland's water-quality function is intact if:	Question 1 is answered "a" or "b," questions 2 and 3 are answered "a," and any other question is answered "a" or "b."
A wetland's water-quality function is impacted or degraded if:	Answers do not satisfy the above- or below-listed criteria.
A wetland's water-quality function is lost or not present if:	Four out of six questions are answered "c."



Frog Pond Crossing - PEM wetland

Hydrologic control (flood control & water supply)

Wetlands function as natural water-storage areas during periods of high runoff and stream flooding.

At times they act as flood regulators by holding floodwater then slowly releasing it downstream. This temporary storage reduces the amount of water downstream during floods, thereby reducing peak flows. Through this flood storage mechanism, wetlands associated with tributaries of streams or rivers can prevent water from all tributaries reaching the stream or river at the same time (this is called desynchronization). Wetlands can also act as floodwater "brakes." For example, water flowing through riverine wetlands during floods is slowed by trees, shrubs, reeds, rushes and other wetland vegetation. Wetlands acting as brakes can reduce flood peaks and thereby reduce flood damage, bank and bed erosion, and other adverse effects caused by fast moving water.

Wetlands also have long-term water holding abilities. Wetlands may store water for longer periods, sometimes for months. The slow draining of these wetlands to surface water or ground water as the water level in the wetland recedes may contribute to maintenance of baseflows in streams hydrologically connected to the wetland. The ability of this long-term water storage to maintain stream flows is called "flow conservation."

Assessment questions

Question 1

Is all or part of the wetland located within the 100-year floodplain or within an enclosed basin? a. Yes. b. No.

Directions

See question 19 in the Wetland Characterization.

Rationale

Wetlands located within a floodplain or enclosed basin have a greater opportunity to receive and store water from surface flows and to release it slowly downstream or into the groundwater.

Notes

Question 2

Is there evidence of flooding or ponding during a portion of the growing season?

- a. Yes.
- b. Unable to determine or not applicable.
- c. No.

Directions

See question 37 in the Wetland Characterization.

Rationale

Water marks are valid indicators of seasonal and episodic stage fluctuations in wetlands and, as such, are strong indicators of storage function.

Question 3

What is the wetland's area in acres?

- a. More than 5 acres.
- b. Between .5 acres and 5 acres.
- c. Less than .5 acres.

Directions

See question 17 in the Wetland Characterization.

Rationale

Generally, the larger the wetland, the greater its ability to store and attenuate flood flows.

Question 4

Is waterflow out of the wetland restricted (e.g., beaver dam, concrete structure, undersized culvert)?

- a. Yes, the outlet is restricted or the wetland has no outlet.
- b. Minor restrictions slow down the water (i.e., undersized culvert.)
- c. No, the outlet has unrestricted flow.

Directions

See question 38 in the Wetland Characterization.

Rationale

Wetlands with no outlets or with restricted or controlled outlets generally will store greater amounts of water than wetlands with unrestricted flow outlets. Also, the wetland can store water for slower release into the water system.

Question 5

What is the dominant wetland vegetation cover type?

- a. Woody vegetation.
- b. Emergent vegetation and ponding, or open water only.
- c. Emergent vegetation or wet meadow.

Directions

See question 23 in the Wetland Characterization.

Rationale

Densely vegetated wetlands with vegetation greater than 6 feet tall are better able to control flood flows than wetlands dominated by open water or low growing vegetation, which generally offers little resistance.

Question 6

What is the dominant existing land use, within 500 feet of the wetland on the downstream or down-slope edge of the wetland?

- a. Developed uses.
- b. Agriculture.
- c. Exclusive Forest Use and Open Space.

Directions

See question 16 in the Wetland Characterization.

Rationale

If the wetland is upstream from developed areas, its ability to control floods becomes more important.

Question 7

What is the dominant land use in the watershed upstream from the assessment area?

- a. Urban or urbanizing.
- b. Agriculture.
- c. Forested or natural area.

Directions

See question 6 in the Wetland Characterization.

Rationale

Runoff volume is directly related to the level of development in the watershed: The more development, the more runoff. The opportunity for the wetland to provide flood control and flow conservation to a community is greater where runoff is greater.

Notes

Notes

Hydrologic control: assessment criteria

A wetland's hydrologic control function is intact if:

Four or more questions are answered "a."

A wetland's hydrologic control function is impacted or degraded if:

Answers do not satisfy the above- or below-listed criteria.

A wetland's hydrologic control function is lost or not present if:

Four or more questions are answered "c."

Exhibit G: Preliminary Stormwater Report

Frog Pond Crossing Wilsonville, Oregon Preliminary Stormwater Report

Date: November 2021

Client: Venture Properties, Inc.

Engineering Contact: Amy Downhour, PE
(503) 563-6151 | Downhoura@aks-eng.com

Prepared By: Vu Nguyen, PE

Engineering Firm: AKS Engineering & Forestry, LLC
12965 SW Herman Road Suite 100
Tualatin, OR 97062

AKS Job Number: 5252



Contents

1.0	Purpose of Report	1
2.0	Project Description	1
3.0	Regulatory Design Criteria	1
3.1.	Water Quality Requirement	1
3.2.	Flow Control Requirement	1
4.0	Design Methodology	1
5.0	Design Parameters	2
5.1.	Design Storm.....	2
5.1.1.	On-Site Inlet and Conduit Sizing	2
5.1.2.	Upstream and Off-site Basin.....	2
5.2.	Pre-developed Site Topography and Land Use	2
5.2.1.	Site Topography.....	2
5.2.2.	Land Use	2
5.3.	Soil Type.....	2
5.4.	Post-developed Site Topography and Land Use	2
5.4.1.	Site Topography.....	2
5.4.2.	Land Use	2
5.4.3.	Post-Developed Input Parameters	2
5.5.	Infiltration Rate.....	2
6.0	Calculation Methodology	3
6.1.	Proposed Stormwater Conduit Sizing and Inlet Spacing	3
6.2.	Proposed Stormwater Quality Facility Design	3
6.3.	Proposed Stormwater Flow Control Facility Design	3
6.4.	Emergency Overflow Calculations.....	3
6.5.	Downstream Analysis	3

Appendices

Appendix A: Vicinity Map

Appendix B: Pre-developed Catchment Map and Detail

Appendix C: Post-developed Catchment Map and Detail

Appendix D: BMP Sizing Tool Report

Appendix E: Stormwater Facilities Location Map

Appendix F: Emergency Overflow Calculations

Appendix G: Information from the NRCS Soil Survey of Clackamas County, Oregon

Appendix H: Relevant Information

Appendix I: Downstream Analysis

Preliminary Stormwater Report

FROG POND CROSSING, CITY OF WILSONVILLE, OREGON

1.0 Purpose of Report

The purpose of this report is to analyze the effect development of Frog Pond Crossing will have on the downstream stormwater conveyance system, document the criteria the proposed stormwater system was designed to meet, identify the sources of information on which the analysis was based, detail the design methodology, and document the results of the analysis.

2.0 Project Description

The development is located on Tax Lots 100, 300, and 302 of Clackamas County Assessor's Map 3 1W 12D. The subject site is located on the west side of SW Stafford Road and north side of SW Frog Pond Lane in Wilsonville, Oregon. The development area is ±8.46 acres. The site area generally slopes toward the southwest and northeast corners of the site. Stormwater runoff from this development will be captured in two subbasins, the north basin and south basin. Stormwater runoff from the basins will be collected and routed to new low impact development (LID) stormwater facilities throughout the site to meet City standards for water quality and flow control. Stormwater runoff from the south basin will discharge to the storm conveyance system on SW Frog Pond Lane, and stormwater runoff from the north basin will discharge to the culvert, which flows under SW Stafford Road.

3.0 Regulatory Design Criteria

3.1. Water Quality Requirement

Per City of Wilsonville 2015 Stormwater & Surface Water Design & Construction Standards, water quality facilities shall be designed to capture and treat 80 percent of the average annual runoff volume to the maximum extent practicable (MEP) with the goal of removing 70 percent of total suspended solids (TSS). The BMP Sizing Tool addresses these water quality requirements to size stormwater management facilities meeting best management practices (BMPs).

3.2. Flow Control Requirement

Per the 2015 City of Wilsonville *Stormwater & Surface Water Design & Construction Standards*, the duration of peak flow rates from post-development conditions shall be less than or equal to the duration of peak flow rates from pre-developed conditions for all peak flows between 42 percent of the 2-year design storm peak flow rate and the 10-year design storm peak flow rate. The BMP Sizing Tool incorporates these flow control requirements to size stormwater management facilities.

4.0 Design Methodology

The BMP Sizing Tool was used to design and size LID stormwater facilities to meet City standards. The Santa Barbara Urban Hydrograph (SBUH) method will be used to design the stormwater conveyance system. The SBUH method uses the Soil Conservation Service (SCS) Type 1A 24-hour storm. HydroCAD computer software aided in the analysis.

5.0 Design Parameters

5.1. Design Storm

5.1.1. On-Site Inlet and Conduit Sizing

Stormwater inlets for the site will be placed at locations that will adequately capture stormwater runoff from the roadways. The on-site stormwater conduit pipes will be sized with Manning's equation, based on peak flows for the 25-year, 3.9-inch storm event.

5.1.2. Upstream and Off-site Basin

There is no potential stormwater runoff from upstream, and no off-site basin will drain to the site.

5.2. Pre-developed Site Topography and Land Use

5.2.1. Site Topography

The site area is convex, generally sloping toward the southwest and northeast corners of the site. Vegetative cover on the site consists of trees and grass.

5.2.2. Land Use

Currently, Tax Lots 300 and 302 are vacant and Tax Lot 100 has an existing single-family house and outbuilding. All existing structures will be removed for the development.

5.3. Soil Type

The soils on site are classified as Aloha silt loam (hydrologic soil group C/D) and Woodburn silt loam (hydrologic soil group C) by the Natural Resources Conservation Service (NRCS) Soil Survey for Clackamas County. Information on this soil type is provided in Appendix G.

5.4. Post-developed Site Topography and Land Use

5.4.1. Site Topography

The post-developed site topography will be altered from the pre-developed site topography to allow the construction of public streets, a private alley, single-family homes, and other associated infrastructure and features.

5.4.2. Land Use

The post-developed land use will consist of 29 lots for single-family homes, public streets, a private alley, and stormwater facilities.

5.4.3. Post-Developed Input Parameters

Per City of Wilsonville 2015 Stormwater & Surface Water Design & Construction Standards, each of the detached single-family dwelling lots was assessed with 2,750 square feet of impervious area.

5.5. Infiltration Rate

Per the infiltration test result prepared by GeoPacific Engineering, Inc. dated April 2, 2021, falling-head infiltration testing conducted on the project site demonstrated a measured infiltration rate of 0.0 inches per hour.

6.0 Calculation Methodology

6.1. Proposed Stormwater Conduit Sizing and Inlet Spacing

The on-site stormwater conduit pipes will be sized using Manning's equation for the 25-year, 3.9-inch storm event. Stormwater inlets will be placed at locations to adequately capture stormwater runoff from the streets.

6.2. Proposed Stormwater Quality Facility Design

For the south basin, stormwater planters, vegetated swales, and rain gardens will provide water quality management for stormwater runoff from impervious areas within the new street right-of-way and roof areas on lots. For the north basin, vegetated swales and a detention pond will provide water quality management for stormwater runoff from impervious areas within the new street right-of-way, private alley, and roof areas on lots.

These LID stormwater facilities were sized with the BMP Sizing Tool to accommodate flows generated by developed areas of the subject property in compliance with City water quality requirements (described in Section 3.1).

6.3. Proposed Stormwater Flow Control Facility Design

For the south basin, stormwater planters, vegetated swales, and rain gardens will provide flow control management for stormwater runoff from impervious areas within the new street right-of-way and roof areas on lots. For the north basin, a detention pond will provide flow control management for stormwater runoff from impervious areas within the new street right-of-way, private alley, and roof areas on lots.

These LID stormwater facilities were sized with the BMP Sizing Tool to accommodate flows generated by developed areas of the subject property in compliance with City flow control requirements (described in Section 3.2).

6.4. Emergency Overflow Calculations

The emergency overflow weir of the detention pond was sized to convey the 100-year storm event. Calculations are included in Appendix F. If the stormwater facility's outlet structures become plugged and cannot convey runoff from the site, the overflow stormwater from the stormwater facility will sheet flow across the overflow riprap pad and down to the existing wetland area.

6.5. Downstream Analysis

Peak flow discharges from the stormwater facilities will be detained and metered out at or below the pre-development runoff condition. Therefore, this project will not negatively impact downstream capacity.

For the south basin, stormwater will discharge to new stormwater conveyance systems that are being installed with Frog Pond Ridge. These storm lines have been sized under Frog Pond Ridge Stormwater Management Plan to accommodate this developed basin. Downstream analysis has been analyzed in the Frog Pond Ridge Stormwater Management Plan.

For the north basin, stormwater will discharge to existing culvert under SW Stafford Road and then outfall into existing drainage channel on the east side of SW Stafford Road. Per the downstream analysis that is included in Appendix I, existing downstream culvert and channel has the capacity to convey the 25-year storm from this developed basin.

Appendix A: Vicinity Map

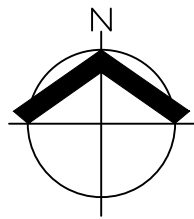
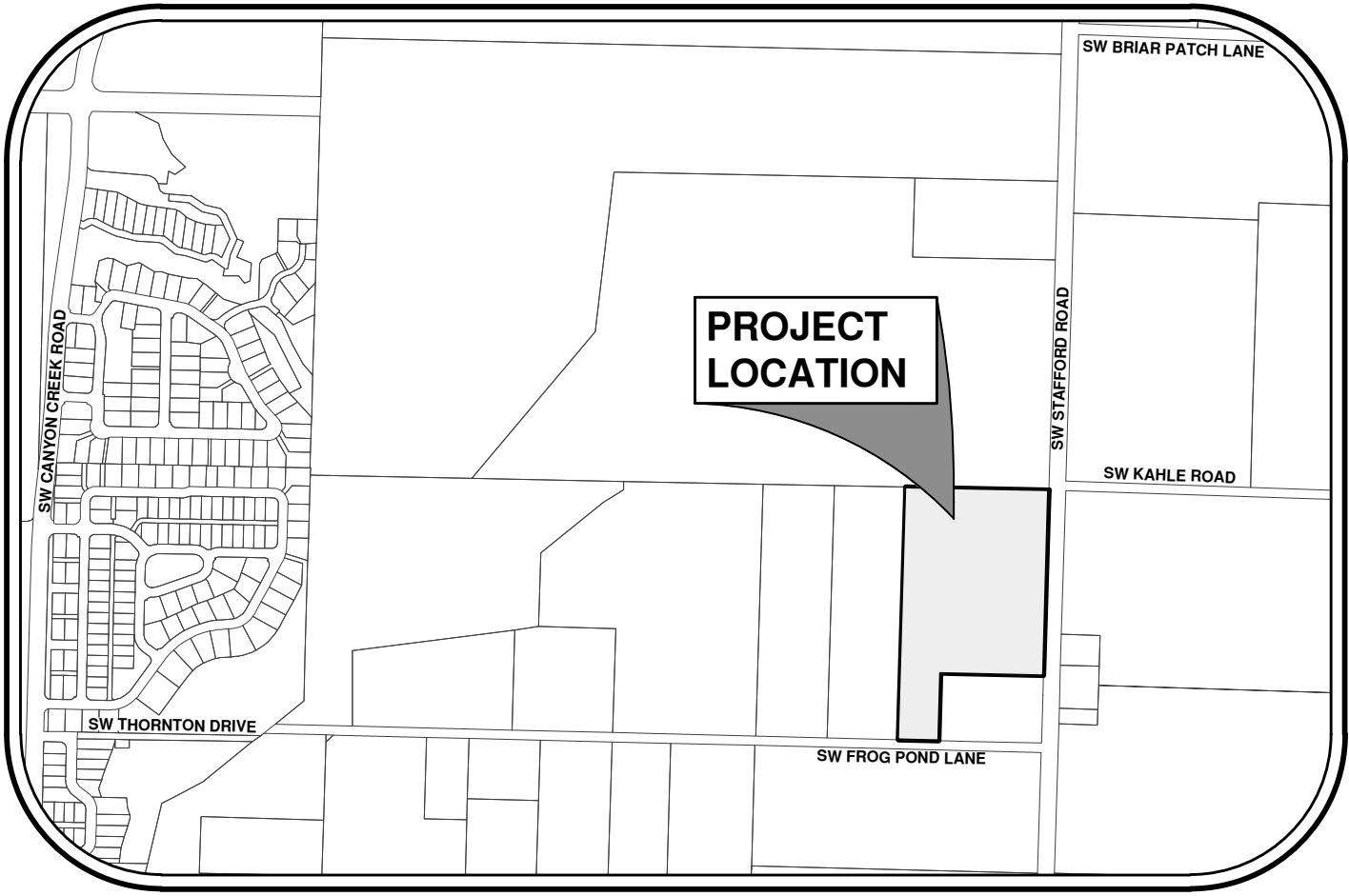

VICINITY MAP

NOT TO SCALE

Appendix B: Pre-developed Catchment Map and Detail

**PRE-DEVELOPED BASIN MAP
 FROG POND CROSSING
 VENTURE PROPERTIES, INC.
 WILSONVILLE, OREGON**

**PRELIMINARY
 NOT FOR
 CONSTRUCTION**

JOB NUMBER:	5252
DATE:	06/08/2021
DESIGNED BY:	AJD
DRAWN BY:	NLB
CHECKED BY:	MD

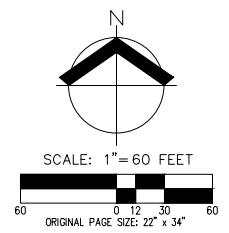
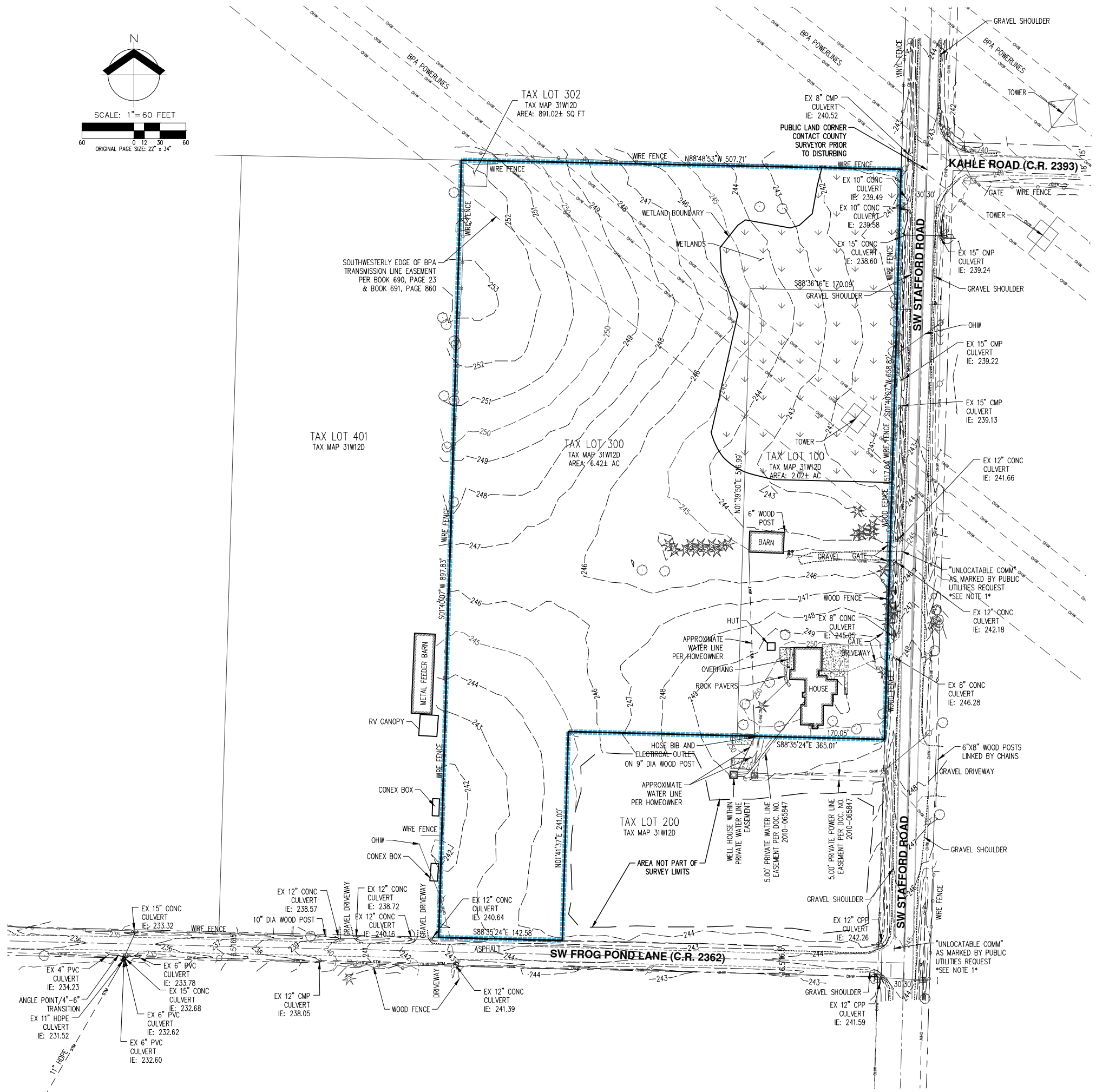

Appendix C: Post-developed Catchment Map and Detail

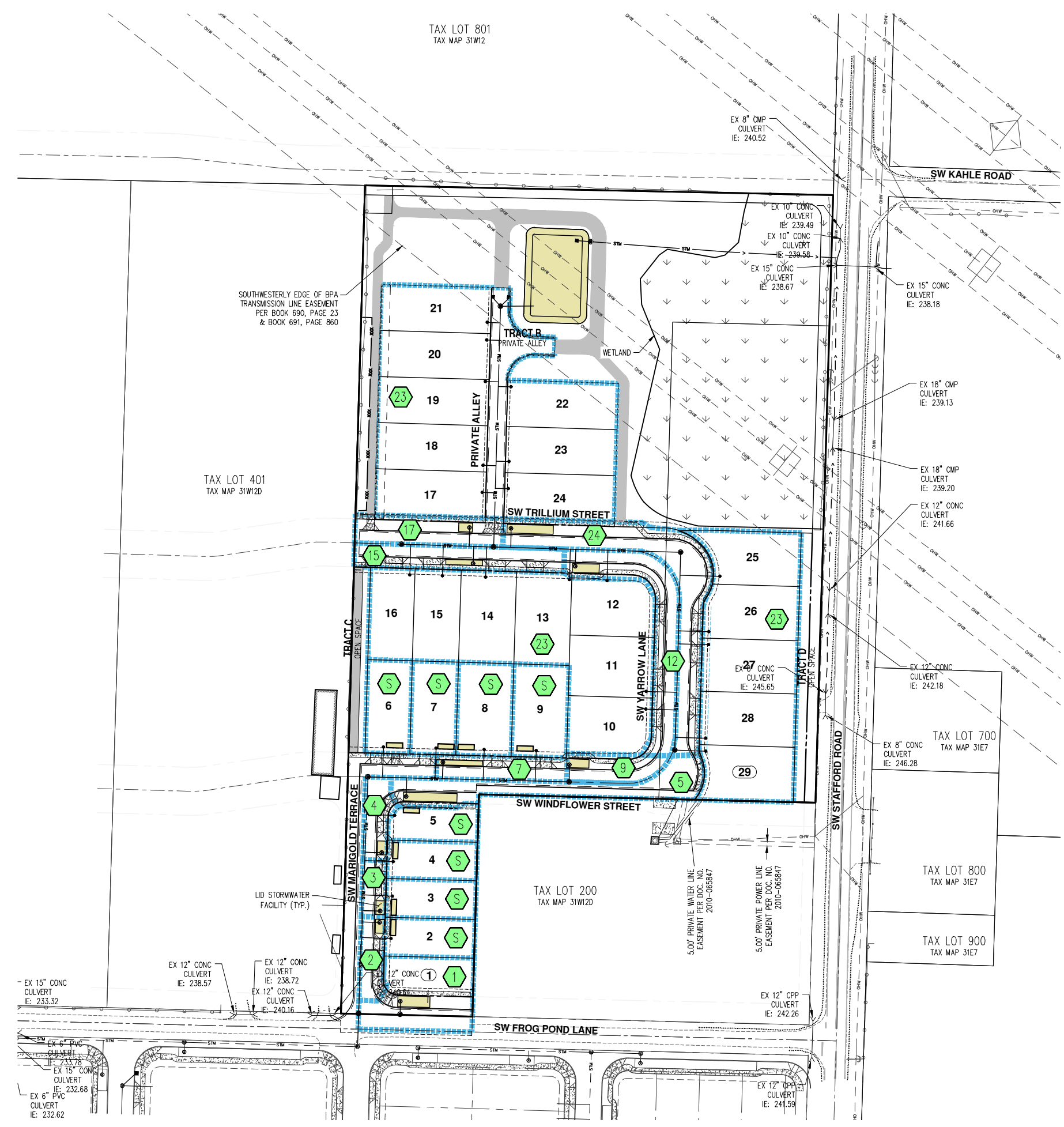
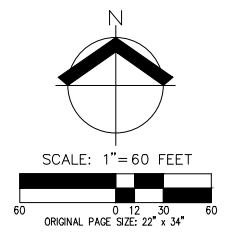

**POST-DEVELOPED BASIN MAP
 FROG POND CROSSING
 VENTURE PROPERTIES, INC.
 WILSONVILLE, OREGON**

**PRELIMINARY
 NOT FOR
 CONSTRUCTION**

JOB NUMBER:	5252
DATE:	08/26/2021
DESIGNED BY:	AJD
DRAWN BY:	NLB
CHECKED BY:	MD

Appendix D: BMP Sizing Tool Report

WES BMP Sizing Report

Project Information

Project Name	5252
Project Type	Subdivision
Location	
Stormwater Management Area	5000
Project Applicant	AKS
Jurisdiction	OutofDistrict

Drainage Management Area

Name	Area (sq-ft)	Pre-Project Cover	Post-Project Cover	DMA Soil Type	BMP
Basin S - Roof for Single Lot	2,750	Grass	Roofs	D	Planter for Single Lot
Basin 2 Impervious	2,375	Grass	ConventionalConcrete	D	Basin 2 Planter
Basin 2 Pervious	1,345	Grass	LandscapeSoil	D	Basin 2 Planter
Basin 1 Impervious	5,055	Grass	ConventionalConcrete	D	Basin 1 Swale
Basin 1 Pervious	1,290	Grass	LandscapeSoil	D	Basin 1 Swale
Basin 3 Impervious	1,600	Grass	ConventionalConcrete	D	Basin 3 Planter
Basin 3 Pervious	2,650	Grass	LandscapeSoil	D	Basin 3 Planter
Basin 4 Impervious	2,530	Grass	ConventionalConcrete	D	Basin 4 Planter
Basin 4 Pervious	1,300	Grass	LandscapeSoil	D	Basin 4 Planter
Basin 5 Impervious	5,665	Grass	ConventionalConcrete	C	Basin 5 Swale
Basin 5 Pervious	3,965	Grass	LandscapeSoil	C	Basin 5 Swale
Basin 7 Impervious	3,435	Grass	ConventionalConcrete	D	Basin 7 Planter
Basin 7 Pervious	8,060	Grass	LandscapeSoil	D	Basin 7 Planter
Basin 9 Impervious	2,615	Grass	ConventionalConcrete	C	Basin 9 Swale

Basin 9 Pervious	1,150	Grass	LandscapeCsoil	C	Basin 9 Swale
Basin 12 Impervious	8,765	Grass	ConventionalConcrete	D	Basin 12 Swale
Basin 12 Pervious	13,205	Grass	LandscapeDsoil	D	Basin 12 Swale
Basin 15 Impervious	5,925	Grass	ConventionalConcrete	D	Basin 15 Planter
Basin 15 Pervious	10,600	Grass	LandscapeDsoil	D	Basin 15 Planter
Basin S - Roof for Single Lot	2,750	Grass	Roofs	D	Rain Garden for Single Lot
Basin 24 Impervious	12,000	Grass	ConventionalConcrete	D	Basin 24 Swale
Basin 24 Pervious	21,600	Grass	LandscapeDsoil	D	Basin 24 Swale
Basin 17 Impervious	4,990	Grass	ConventionalConcrete	D	Basin 17 Swale
Basin 17 Pervious	3,850	Grass	LandscapeDsoil	D	Basin 17 Swale
Basin 23 Impervious	6,780	Grass	ConventionalConcrete	D	Basin 23 Pond
Basin 23 Roofs	55,000	Grass	Roofs	C	Basin 23 Pond
Basin 23 Pervious	17,855	Grass	LandscapeCsoil	C	Basin 23 Pond

LID Facility Sizing Details

LID ID	Design Criteria	BMP Type	Facility Soil Type	Minimum Area (sq-ft)	Planned Areas (sq-ft)	Orifice Diameter (in)
Rain Garden for Single Lot	FlowControlAndTreatment	Rain Garden - Filtration	Lined	110.0	110.0	0.5
Planter for Single Lot	FlowControlAndTreatment	Stormwater Planter - Filtration	Lined	82.5	85.0	0.6
Basin 2 Planter	FlowControlAndTreatment	Stormwater Planter - Filtration	Lined	99.5	100.0	0.7
Basin 3 Planter	FlowControlAndTreatment	Stormwater Planter - Filtration	Lined	103.7	105.0	0.7
Basin 4 Planter	FlowControlAndTreatment	Stormwater Planter - Filtration	Lined	103.2	105.0	0.7
Basin 7 Planter	FlowControlAndTreatment	Stormwater Planter - Filtration	Lined	272.3	275.0	1.2

Basin 15 Planter	WaterQuality	Stormwater Planter - Filtration	Lined	200.2	210.0	0.6
Basin 1 Swale	FlowControlAndTreatment	Vegetated Swale - Filtration	Lined	238.3	240.0	0.9
Basin 5 Swale	FlowControlAndTreatment	Vegetated Swale - Filtration	Lined	535.3	540.0	0.9
Basin 9 Swale	FlowControlAndTreatment	Vegetated Swale - Filtration	Lined	223.3	225.0	0.6
Basin 12 Swale	WaterQuality	Vegetated Swale - Filtration	Lined	270.1	275.0	0.7
Basin 24 Swale	WaterQuality	Vegetated Swale - Filtration	Lined	406.8	410.0	0.9
Basin 17 Swale	WaterQuality	Vegetated Swale - Filtration	Lined	115.3	120.0	0.5

Pond Sizing Details

Pond ID	Design Criteria(1)	Facility Soil Type	Max Depth (ft)(2)	Top Area (sq-ft)	Side Slope (1:H)	Facility Vol. (cu-ft)(3)	Water Storage Vol. (cu-ft)(4)	Adequate Size?
Basin 23 Pond	FCWQT	Lined	4.00	4,794.0	3	13,298.2	7,953.7	Yes

1. FCWQT = Flow control and water quality treatment, WQT = Water quality treatment only

2. Depth is measured from the bottom of the facility and includes the three feet of media (drain rock, separation layer and growing media).

3. Maximum volume of the facility. Includes the volume occupied by the media at the bottom of the facility.

4. Maximum water storage volume of the facility. Includes water storage in the three feet of soil media assuming a 40 percent porosity.

Simple Pond Geometry Configuration

Pond ID: Basin 23 Pond

Design: FlowControlAndTreatment

Shape Curve

Depth (ft)	Area (sq ft)
4.0	4,794.0

Outlet Structure Details

Lower Orifice Invert (ft)	0.0
Lower Orifice Dia (in)	2.8
Upper Orifice Invert(ft)	2.7
Upper Orifice Dia (in)	6.4
Overflow Weir Invert(ft)	3.0
Overflow Weir Length (ft)	6.3

Flow Frequency Chart

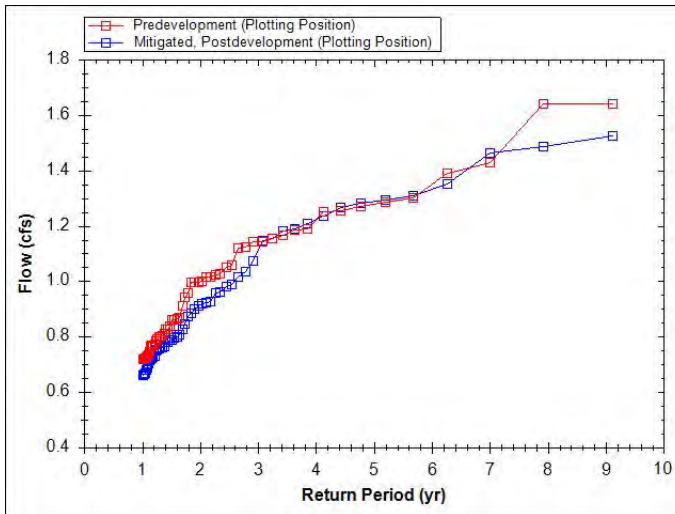

Flow Duration Chart

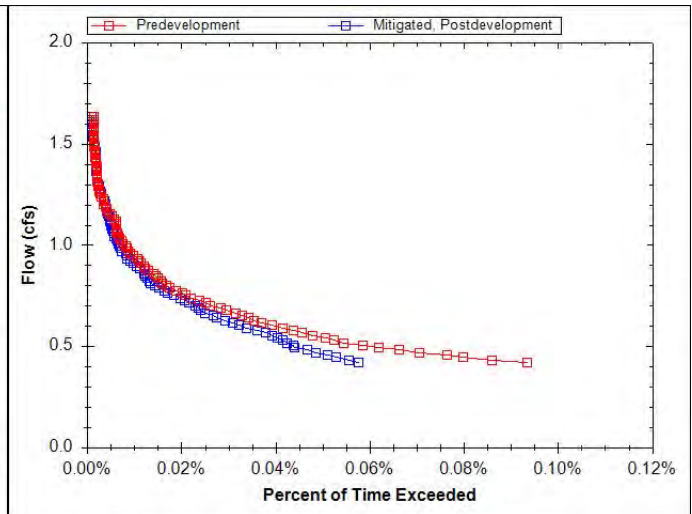

Appendix E: Stormwater Facilities Location Map

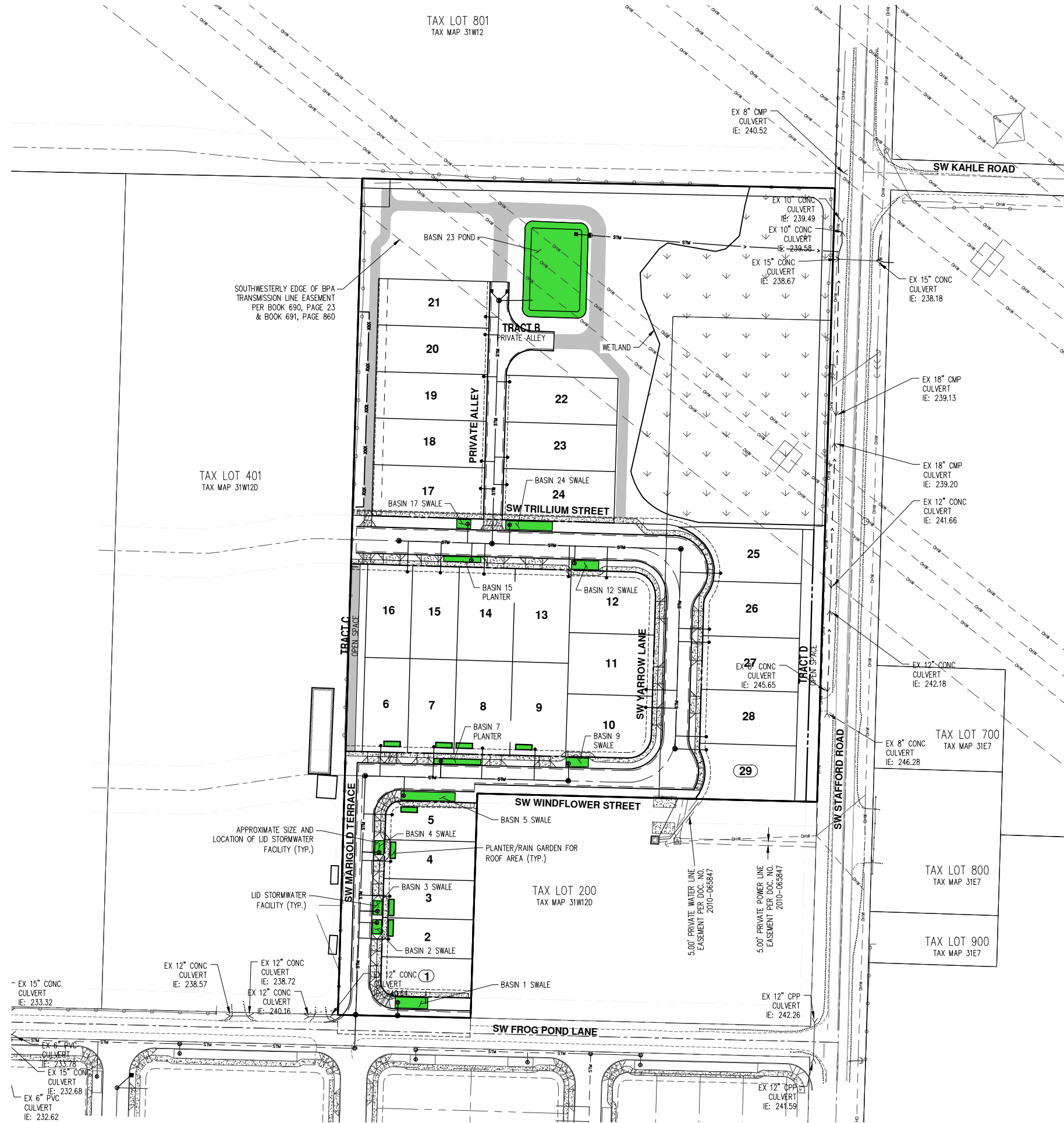
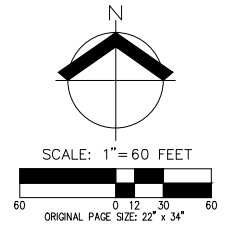

**STORMWATER FACILITIES LOCATION
 FROG POND CROSSING
 VENTURE PROPERTIES, INC.
 WILSONVILLE, OREGON**

**PRELIMINARY
 NOT FOR
 CONSTRUCTION**

JOB NUMBER:	5252
DATE:	08/26/2021
DESIGNED BY:	AJD
DRAWN BY:	NLB
CHECKED BY:	MD

Appendix F: Emergency Overflow Calculations

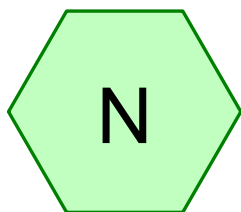

Basin

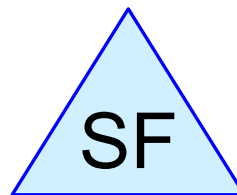

LID STORMWATER
FACILITY

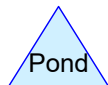
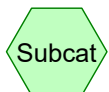

5252 HydroCAD Overflow

Prepared by AKS Engineering & Forestry, LLC

Printed 6/10/2021

HydroCAD® 10.00-22 s/n 01338 © 2018 HydroCAD Software Solutions LLC

Area Listing (all nodes)

Area (sq-ft)	CN	Description (subcatchment-numbers)
93,460	98	Impervious (N)
67,110	86	Pervious (N)

5252 HydroCAD Overflow

Type IA 24-hr 100-YR Rainfall=4.50"

Prepared by AKS Engineering & Forestry, LLC

Printed 6/10/2021

HydroCAD® 10.00-22 s/n 01338 © 2018 HydroCAD Software Solutions LLC

Time span=0.00-24.00 hrs, dt=0.10 hrs, 241 points

Runoff by SBUH method, Split Pervious/Imperv.

Reach routing by Stor-Ind+Trans method - Pond routing by Stor-Ind method

Subcatchment N: Basin

Runoff Area=160,570 sf 58.21% Impervious Runoff Depth>3.73"

Tc=5.0 min CN=86/98 Runoff=3.44 cfs 49,914 cf

Pond SF: LID STORMWATER FACILITY

Peak Elev=244.61' Storage=17,959 cf Inflow=3.44 cfs 49,914 cf

Outflow=1.82 cfs 32,495 cf

5252 HydroCAD Overflow

Prepared by AKS Engineering & Forestry, LLC

HydroCAD® 10.00-22 s/n 01338 © 2018 HydroCAD Software Solutions LLC

Type IA 24-hr 100-YR Rainfall=4.50"

Printed 6/10/2021

Summary for Subcatchment N: Basin

Runoff = 3.44 cfs @ 7.94 hrs, Volume= 49,914 cf, Depth> 3.73"

Runoff by SBUH method, Split Pervious/Imperv., Time Span= 0.00-24.00 hrs, dt= 0.10 hrs
Type IA 24-hr 100-YR Rainfall=4.50"

	Area (sf)	CN	Description
*	93,460	98	Impervious
*	67,110	86	Pervious
	160,570	93	Weighted Average
	67,110		41.79% Pervious Area
	93,460		58.21% Impervious Area

Tc (min)	Length (feet)	Slope (ft/ft)	Velocity (ft/sec)	Capacity (cfs)	Description
5.0					Direct Entry,

Subcatchment N: Basin

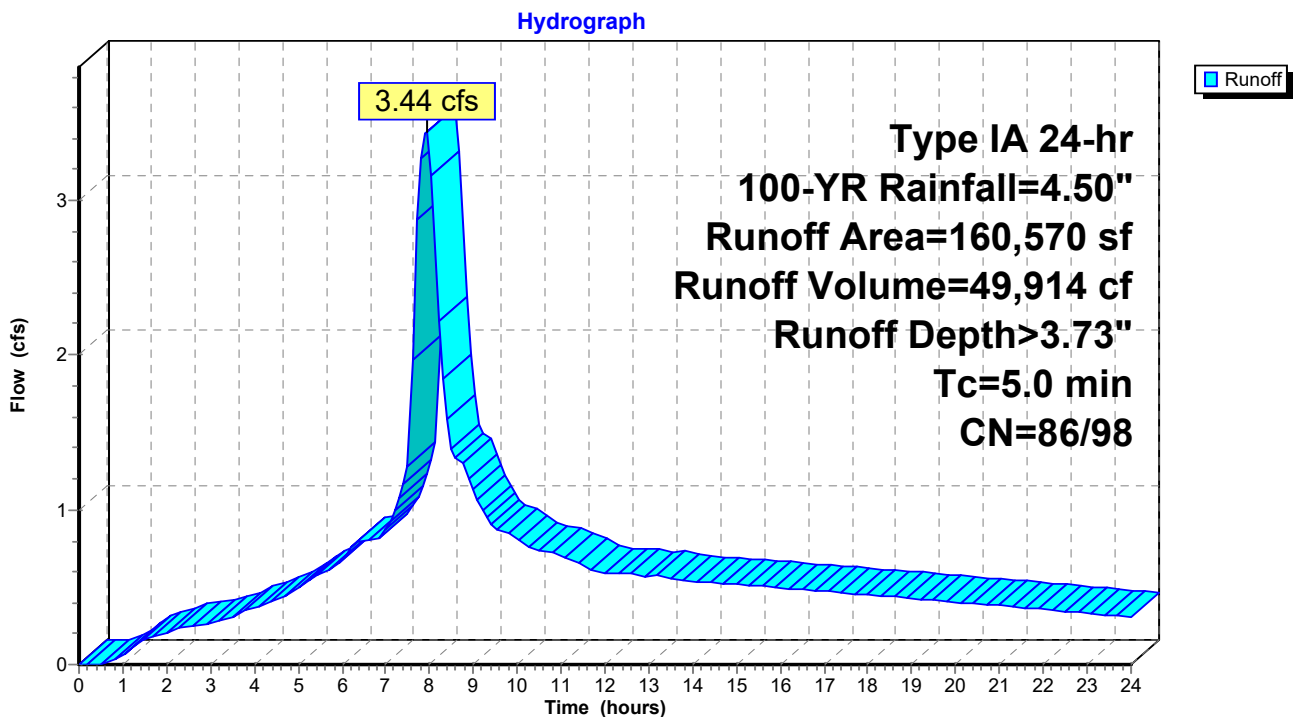

5252 HydroCAD Overflow

Type IA 24-hr 100-YR Rainfall=4.50"

Prepared by AKS Engineering & Forestry, LLC

Printed 6/10/2021

HydroCAD® 10.00-22 s/n 01338 © 2018 HydroCAD Software Solutions LLC

Summary for Pond SF: LID STORMWATER FACILITY

Inflow Area = 160,570 sf, 58.21% Impervious, Inflow Depth > 3.73" for 100-YR event
 Inflow = 3.44 cfs @ 7.94 hrs, Volume= 49,914 cf
 Outflow = 1.82 cfs @ 8.34 hrs, Volume= 32,495 cf, Atten= 47%, Lag= 24.3 min
 Primary = 1.82 cfs @ 8.34 hrs, Volume= 32,495 cf

Routing by Stor-Ind method, Time Span= 0.00-24.00 hrs, dt= 0.10 hrs / 2
 Peak Elev= 244.61' @ 8.34 hrs Surf.Area= 6,549 sf Storage= 17,959 cf

Plug-Flow detention time= 379.7 min calculated for 32,495 cf (65% of inflow)
 Center-of-Mass det. time= 172.3 min (861.8 - 689.5)

Volume	Invert	Avail.Storage	Storage Description			
#1	239.50'	20,572 cf	Custom Stage Data (Pyramidal) Listed below (Recalc)			
Elevation (feet)	Surf.Area (sq-ft)	Voids (%)	Inc.Store (cubic-feet)	Cum.Store (cubic-feet)	Wet.Area (sq-ft)	
239.50	4,765	0.0	0	0	4,765	
242.40	4,765	40.0	5,527	5,527	5,566	
242.50	4,765	100.0	476	6,004	5,593	
243.50	5,635	100.0	5,194	11,198	6,510	
245.00	6,885	100.0	9,374	20,572	7,847	

Device	Routing	Invert	Outlet Devices
#1	Primary	244.50'	15.0' long Sharp-Crested Rectangular Weir 2 End Contraction(s)

Primary OutFlow Max=1.72 cfs @ 8.34 hrs HW=244.61' (Free Discharge)
 ↳1=Sharp-Crested Rectangular Weir (Weir Controls 1.72 cfs @ 1.07 fps)

5252 HydroCAD Overflow

Prepared by AKS Engineering & Forestry, LLC

HydroCAD® 10.00-22 s/n 01338 © 2018 HydroCAD Software Solutions LLC

Type IA 24-hr 100-YR Rainfall=4.50"

Printed 6/10/2021

Pond SF: LID STORMWATER FACILITY

Hydrograph

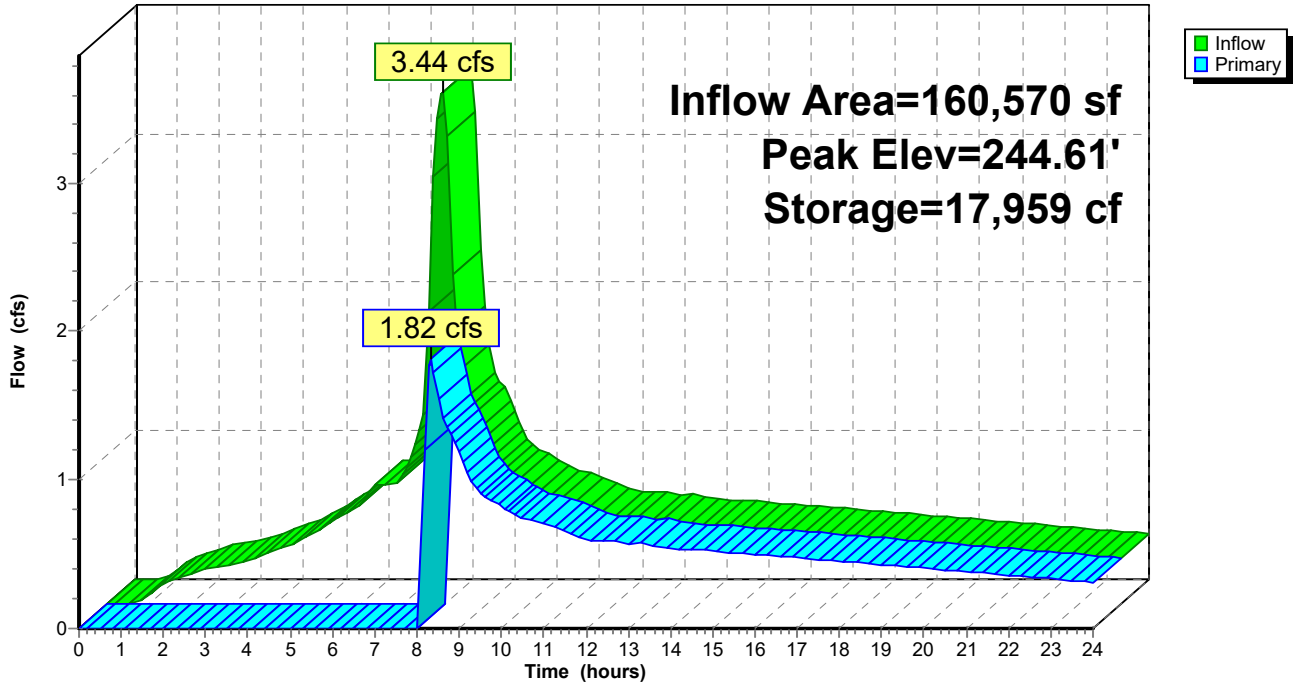

Appendix G: Information from the USDA Soil Survey of Clackamas County, Oregon

Custom Soil Resource Report for **Clackamas County Area, Oregon**

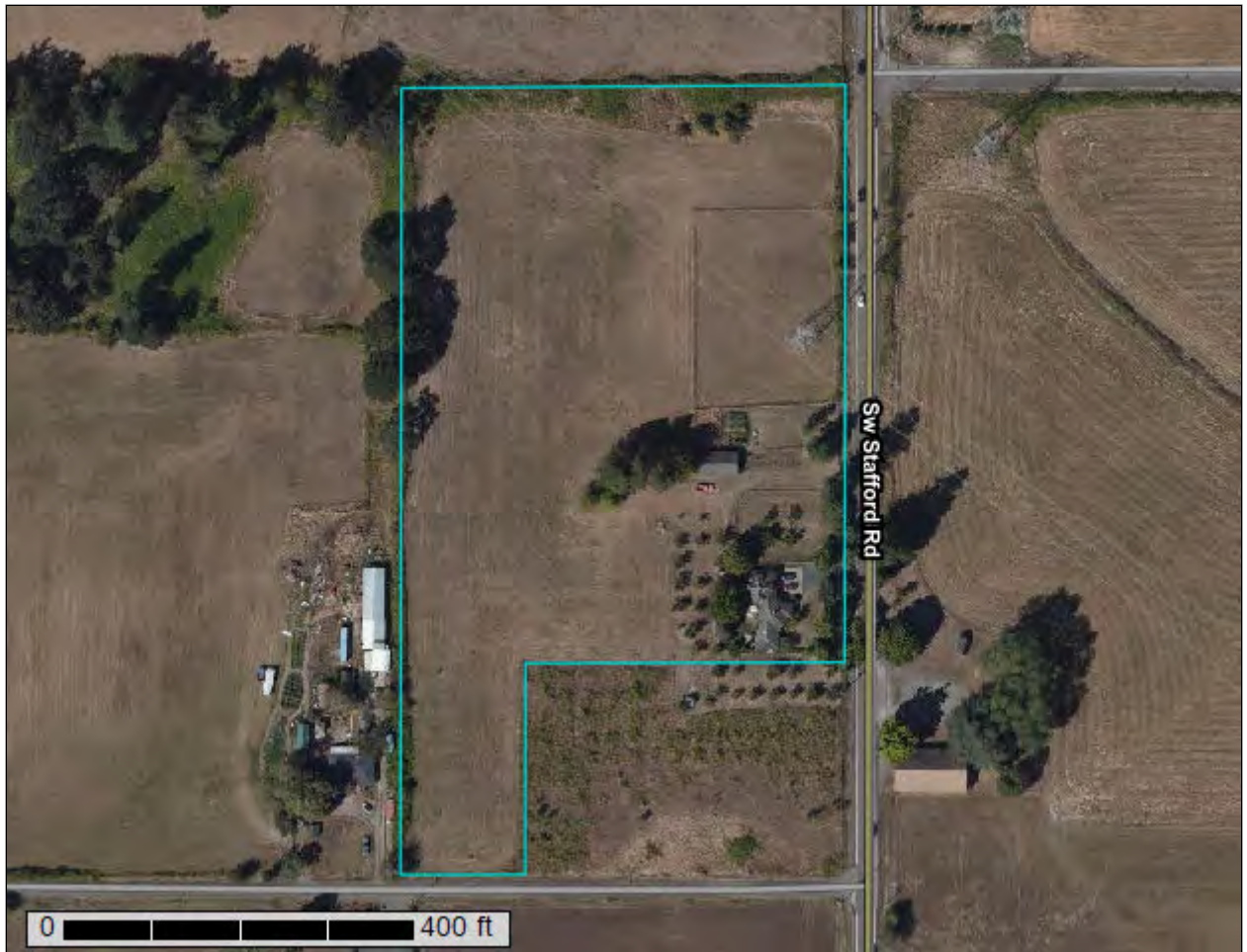

Preface

Soil surveys contain information that affects land use planning in survey areas. They highlight soil limitations that affect various land uses and provide information about the properties of the soils in the survey areas. Soil surveys are designed for many different users, including farmers, ranchers, foresters, agronomists, urban planners, community officials, engineers, developers, builders, and home buyers. Also, conservationists, teachers, students, and specialists in recreation, waste disposal, and pollution control can use the surveys to help them understand, protect, or enhance the environment.

Various land use regulations of Federal, State, and local governments may impose special restrictions on land use or land treatment. Soil surveys identify soil properties that are used in making various land use or land treatment decisions. The information is intended to help the land users identify and reduce the effects of soil limitations on various land uses. The landowner or user is responsible for identifying and complying with existing laws and regulations.

Although soil survey information can be used for general farm, local, and wider area planning, onsite investigation is needed to supplement this information in some cases. Examples include soil quality assessments (<http://www.nrcs.usda.gov/wps/portal/nrcs/main/soils/health/>) and certain conservation and engineering applications. For more detailed information, contact your local USDA Service Center (<https://offices.sc.egov.usda.gov/locator/app?agency=nrcs>) or your NRCS State Soil Scientist (http://www.nrcs.usda.gov/wps/portal/nrcs/detail/soils/contactus/?cid=nrcs142p2_053951).

Great differences in soil properties can occur within short distances. Some soils are seasonally wet or subject to flooding. Some are too unstable to be used as a foundation for buildings or roads. Clayey or wet soils are poorly suited to use as septic tank absorption fields. A high water table makes a soil poorly suited to basements or underground installations.

The National Cooperative Soil Survey is a joint effort of the United States Department of Agriculture and other Federal agencies, State agencies including the Agricultural Experiment Stations, and local agencies. The Natural Resources Conservation Service (NRCS) has leadership for the Federal part of the National Cooperative Soil Survey.

Information about soils is updated periodically. Updated information is available through the NRCS Web Soil Survey, the site for official soil survey information.

The U.S. Department of Agriculture (USDA) prohibits discrimination in all its programs and activities on the basis of race, color, national origin, age, disability, and where applicable, sex, marital status, familial status, parental status, religion, sexual orientation, genetic information, political beliefs, reprisal, or because all or a part of an individual's income is derived from any public assistance program. (Not all prohibited bases apply to all programs.) Persons with disabilities who require

alternative means for communication of program information (Braille, large print, audiotape, etc.) should contact USDA's TARGET Center at (202) 720-2600 (voice and TDD). To file a complaint of discrimination, write to USDA, Director, Office of Civil Rights, 1400 Independence Avenue, S.W., Washington, D.C. 20250-9410 or call (800) 795-3272 (voice) or (202) 720-6382 (TDD). USDA is an equal opportunity provider and employer.

Contents

Preface	2
How Soil Surveys Are Made	5
Soil Map	8
Soil Map.....	9
Legend.....	10
Map Unit Legend.....	11
Map Unit Descriptions.....	11
Clackamas County Area, Oregon.....	13
1A—Aloha silt loam, 0 to 3 percent slopes.....	13
91B—Woodburn silt loam, 3 to 8 percent slopes.....	14
Soil Information for All Uses	16
Soil Properties and Qualities.....	16
Soil Qualities and Features.....	16
Hydrologic Soil Group.....	16
References	21

How Soil Surveys Are Made

Soil surveys are made to provide information about the soils and miscellaneous areas in a specific area. They include a description of the soils and miscellaneous areas and their location on the landscape and tables that show soil properties and limitations affecting various uses. Soil scientists observed the steepness, length, and shape of the slopes; the general pattern of drainage; the kinds of crops and native plants; and the kinds of bedrock. They observed and described many soil profiles. A soil profile is the sequence of natural layers, or horizons, in a soil. The profile extends from the surface down into the unconsolidated material in which the soil formed or from the surface down to bedrock. The unconsolidated material is devoid of roots and other living organisms and has not been changed by other biological activity.

Currently, soils are mapped according to the boundaries of major land resource areas (MLRAs). MLRAs are geographically associated land resource units that share common characteristics related to physiography, geology, climate, water resources, soils, biological resources, and land uses (USDA, 2006). Soil survey areas typically consist of parts of one or more MLRA.

The soils and miscellaneous areas in a survey area occur in an orderly pattern that is related to the geology, landforms, relief, climate, and natural vegetation of the area. Each kind of soil and miscellaneous area is associated with a particular kind of landform or with a segment of the landform. By observing the soils and miscellaneous areas in the survey area and relating their position to specific segments of the landform, a soil scientist develops a concept, or model, of how they were formed. Thus, during mapping, this model enables the soil scientist to predict with a considerable degree of accuracy the kind of soil or miscellaneous area at a specific location on the landscape.

Commonly, individual soils on the landscape merge into one another as their characteristics gradually change. To construct an accurate soil map, however, soil scientists must determine the boundaries between the soils. They can observe only a limited number of soil profiles. Nevertheless, these observations, supplemented by an understanding of the soil-vegetation-landscape relationship, are sufficient to verify predictions of the kinds of soil in an area and to determine the boundaries.

Soil scientists recorded the characteristics of the soil profiles that they studied. They noted soil color, texture, size and shape of soil aggregates, kind and amount of rock fragments, distribution of plant roots, reaction, and other features that enable them to identify soils. After describing the soils in the survey area and determining their properties, the soil scientists assigned the soils to taxonomic classes (units). Taxonomic classes are concepts. Each taxonomic class has a set of soil characteristics with precisely defined limits. The classes are used as a basis for comparison to classify soils systematically. Soil taxonomy, the system of taxonomic classification used in the United States, is based mainly on the kind and character of soil properties and the arrangement of horizons within the profile. After the soil

Custom Soil Resource Report

scientists classified and named the soils in the survey area, they compared the individual soils with similar soils in the same taxonomic class in other areas so that they could confirm data and assemble additional data based on experience and research.

The objective of soil mapping is not to delineate pure map unit components; the objective is to separate the landscape into landforms or landform segments that have similar use and management requirements. Each map unit is defined by a unique combination of soil components and/or miscellaneous areas in predictable proportions. Some components may be highly contrasting to the other components of the map unit. The presence of minor components in a map unit in no way diminishes the usefulness or accuracy of the data. The delineation of such landforms and landform segments on the map provides sufficient information for the development of resource plans. If intensive use of small areas is planned, onsite investigation is needed to define and locate the soils and miscellaneous areas.

Soil scientists make many field observations in the process of producing a soil map. The frequency of observation is dependent upon several factors, including scale of mapping, intensity of mapping, design of map units, complexity of the landscape, and experience of the soil scientist. Observations are made to test and refine the soil-landscape model and predictions and to verify the classification of the soils at specific locations. Once the soil-landscape model is refined, a significantly smaller number of measurements of individual soil properties are made and recorded. These measurements may include field measurements, such as those for color, depth to bedrock, and texture, and laboratory measurements, such as those for content of sand, silt, clay, salt, and other components. Properties of each soil typically vary from one point to another across the landscape.

Observations for map unit components are aggregated to develop ranges of characteristics for the components. The aggregated values are presented. Direct measurements do not exist for every property presented for every map unit component. Values for some properties are estimated from combinations of other properties.

While a soil survey is in progress, samples of some of the soils in the area generally are collected for laboratory analyses and for engineering tests. Soil scientists interpret the data from these analyses and tests as well as the field-observed characteristics and the soil properties to determine the expected behavior of the soils under different uses. Interpretations for all of the soils are field tested through observation of the soils in different uses and under different levels of management. Some interpretations are modified to fit local conditions, and some new interpretations are developed to meet local needs. Data are assembled from other sources, such as research information, production records, and field experience of specialists. For example, data on crop yields under defined levels of management are assembled from farm records and from field or plot experiments on the same kinds of soil.

Predictions about soil behavior are based not only on soil properties but also on such variables as climate and biological activity. Soil conditions are predictable over long periods of time, but they are not predictable from year to year. For example, soil scientists can predict with a fairly high degree of accuracy that a given soil will have a high water table within certain depths in most years, but they cannot predict that a high water table will always be at a specific level in the soil on a specific date.

After soil scientists located and identified the significant natural bodies of soil in the survey area, they drew the boundaries of these bodies on aerial photographs and

Custom Soil Resource Report

identified each as a specific map unit. Aerial photographs show trees, buildings, fields, roads, and rivers, all of which help in locating boundaries accurately.

Soil Map

The soil map section includes the soil map for the defined area of interest, a list of soil map units on the map and extent of each map unit, and cartographic symbols displayed on the map. Also presented are various metadata about data used to produce the map, and a description of each soil map unit.

Custom Soil Resource Report Soil Map



Map Scale: 1:1,610 if printed on A portrait (8.5" x 11") sheet.

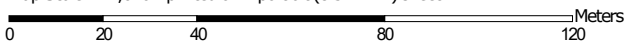

Map projection: Web Mercator Corner coordinates: WGS84 Edge tics: UTM Zone 10N WGS84

MAP LEGEND

Area of Interest (AOI)

 Area of Interest (AOI)



















Soils

 Soil Map Unit Polygons

 Soil Map Unit Lines

 Soil Map Unit Points

Special Point Features

-  Blowout
-  Borrow Pit
-  Clay Spot
-  Closed Depression
-  Gravel Pit
-  Gravelly Spot
-  Landfill
-  Lava Flow
-  Marsh or swamp
-  Mine or Quarry
-  Miscellaneous Water
-  Perennial Water
-  Rock Outcrop
-  Saline Spot
-  Sandy Spot
-  Severely Eroded Spot
-  Sinkhole
-  Slide or Slip
-  Sodic Spot

-  Spoil Area
-  Stony Spot
-  Very Stony Spot
-  Wet Spot
-  Other
-  Special Line Features

Water Features

 Streams and Canals

Transportation

-  Rails
-  Interstate Highways
-  US Routes
-  Major Roads
-  Local Roads

Background

 Aerial Photography

MAP INFORMATION

The soil surveys that comprise your AOI were mapped at 1:20,000.

Warning: Soil Map may not be valid at this scale.

Enlargement of maps beyond the scale of mapping can cause misunderstanding of the detail of mapping and accuracy of soil line placement. The maps do not show the small areas of contrasting soils that could have been shown at a more detailed scale.

Please rely on the bar scale on each map sheet for map measurements.

Source of Map: Natural Resources Conservation Service
 Web Soil Survey URL:
 Coordinate System: Web Mercator (EPSG:3857)

Maps from the Web Soil Survey are based on the Web Mercator projection, which preserves direction and shape but distorts distance and area. A projection that preserves area, such as the Albers equal-area conic projection, should be used if more accurate calculations of distance or area are required.

This product is generated from the USDA-NRCS certified data as of the version date(s) listed below.

Soil Survey Area: Clackamas County Area, Oregon
 Survey Area Data: Version 16, Jun 11, 2020

Soil map units are labeled (as space allows) for map scales 1:50,000 or larger.

Date(s) aerial images were photographed: Aug 1, 2019—Sep 12, 2019

The orthophoto or other base map on which the soil lines were compiled and digitized probably differs from the background imagery displayed on these maps. As a result, some minor shifting of map unit boundaries may be evident.

Map Unit Legend

Map Unit Symbol	Map Unit Name	Acres in AOI	Percent of AOI
1A	Aloha silt loam, 0 to 3 percent slopes	6.3	75.0%
91B	Woodburn silt loam, 3 to 8 percent slopes	2.1	25.0%
Totals for Area of Interest		8.5	100.0%

Map Unit Descriptions

The map units delineated on the detailed soil maps in a soil survey represent the soils or miscellaneous areas in the survey area. The map unit descriptions, along with the maps, can be used to determine the composition and properties of a unit.

A map unit delineation on a soil map represents an area dominated by one or more major kinds of soil or miscellaneous areas. A map unit is identified and named according to the taxonomic classification of the dominant soils. Within a taxonomic class there are precisely defined limits for the properties of the soils. On the landscape, however, the soils are natural phenomena, and they have the characteristic variability of all natural phenomena. Thus, the range of some observed properties may extend beyond the limits defined for a taxonomic class. Areas of soils of a single taxonomic class rarely, if ever, can be mapped without including areas of other taxonomic classes. Consequently, every map unit is made up of the soils or miscellaneous areas for which it is named and some minor components that belong to taxonomic classes other than those of the major soils.

Most minor soils have properties similar to those of the dominant soil or soils in the map unit, and thus they do not affect use and management. These are called noncontrasting, or similar, components. They may or may not be mentioned in a particular map unit description. Other minor components, however, have properties and behavioral characteristics divergent enough to affect use or to require different management. These are called contrasting, or dissimilar, components. They generally are in small areas and could not be mapped separately because of the scale used. Some small areas of strongly contrasting soils or miscellaneous areas are identified by a special symbol on the maps. If included in the database for a given area, the contrasting minor components are identified in the map unit descriptions along with some characteristics of each. A few areas of minor components may not have been observed, and consequently they are not mentioned in the descriptions, especially where the pattern was so complex that it was impractical to make enough observations to identify all the soils and miscellaneous areas on the landscape.

The presence of minor components in a map unit in no way diminishes the usefulness or accuracy of the data. The objective of mapping is not to delineate pure taxonomic classes but rather to separate the landscape into landforms or landform segments that have similar use and management requirements. The delineation of such segments on the map provides sufficient information for the development of resource plans. If intensive use of small areas is planned, however,

Custom Soil Resource Report

onsite investigation is needed to define and locate the soils and miscellaneous areas.

An identifying symbol precedes the map unit name in the map unit descriptions. Each description includes general facts about the unit and gives important soil properties and qualities.

Soils that have profiles that are almost alike make up a *soil series*. Except for differences in texture of the surface layer, all the soils of a series have major horizons that are similar in composition, thickness, and arrangement.

Soils of one series can differ in texture of the surface layer, slope, stoniness, salinity, degree of erosion, and other characteristics that affect their use. On the basis of such differences, a soil series is divided into *soil phases*. Most of the areas shown on the detailed soil maps are phases of soil series. The name of a soil phase commonly indicates a feature that affects use or management. For example, Alpha silt loam, 0 to 2 percent slopes, is a phase of the Alpha series.

Some map units are made up of two or more major soils or miscellaneous areas. These map units are complexes, associations, or undifferentiated groups.

A *complex* consists of two or more soils or miscellaneous areas in such an intricate pattern or in such small areas that they cannot be shown separately on the maps. The pattern and proportion of the soils or miscellaneous areas are somewhat similar in all areas. Alpha-Beta complex, 0 to 6 percent slopes, is an example.

An *association* is made up of two or more geographically associated soils or miscellaneous areas that are shown as one unit on the maps. Because of present or anticipated uses of the map units in the survey area, it was not considered practical or necessary to map the soils or miscellaneous areas separately. The pattern and relative proportion of the soils or miscellaneous areas are somewhat similar. Alpha-Beta association, 0 to 2 percent slopes, is an example.

An *undifferentiated group* is made up of two or more soils or miscellaneous areas that could be mapped individually but are mapped as one unit because similar interpretations can be made for use and management. The pattern and proportion of the soils or miscellaneous areas in a mapped area are not uniform. An area can be made up of only one of the major soils or miscellaneous areas, or it can be made up of all of them. Alpha and Beta soils, 0 to 2 percent slopes, is an example.

Some surveys include *miscellaneous areas*. Such areas have little or no soil material and support little or no vegetation. Rock outcrop is an example.

Clackamas County Area, Oregon

1A—Aloha silt loam, 0 to 3 percent slopes

Map Unit Setting

National map unit symbol: 2231
Elevation: 150 to 400 feet
Mean annual precipitation: 40 to 60 inches
Mean annual air temperature: 52 to 54 degrees F
Frost-free period: 165 to 210 days
Farmland classification: Prime farmland if drained

Map Unit Composition

Aloha and similar soils: 85 percent
Minor components: 5 percent
Estimates are based on observations, descriptions, and transects of the mapunit.

Description of Aloha

Setting

Landform: Terraces
Landform position (three-dimensional): Tread
Down-slope shape: Linear
Across-slope shape: Linear
Parent material: Stratified glaciolacustrine deposits

Typical profile

H1 - 0 to 8 inches: silt loam
H2 - 8 to 51 inches: silt loam
H3 - 51 to 80 inches: silt loam

Properties and qualities

Slope: 0 to 3 percent
Depth to restrictive feature: More than 80 inches
Drainage class: Somewhat poorly drained
Capacity of the most limiting layer to transmit water (Ksat): Moderately high (0.20 to 0.57 in/hr)
Depth to water table: About 18 to 24 inches
Frequency of flooding: None
Frequency of ponding: None
Available water capacity: High (about 11.9 inches)

Interpretive groups

Land capability classification (irrigated): 2w
Land capability classification (nonirrigated): 2w
Hydrologic Soil Group: C/D
Forage suitability group: Somewhat Poorly Drained (G002XY005OR)
Other vegetative classification: Somewhat Poorly Drained (G002XY005OR)
Hydric soil rating: No

Minor Components

Huberly

Percent of map unit: 3 percent
Landform: Swales on terraces
Landform position (three-dimensional): Tread

Custom Soil Resource Report

Down-slope shape: Linear
Across-slope shape: Linear
Other vegetative classification: Poorly Drained (G002XY006OR)
Hydric soil rating: Yes

Dayton

Percent of map unit: 2 percent
Landform: Terraces
Landform position (three-dimensional): Tread
Down-slope shape: Linear
Across-slope shape: Linear
Other vegetative classification: Poorly Drained (G002XY006OR)
Hydric soil rating: Yes

91B—Woodburn silt loam, 3 to 8 percent slopes

Map Unit Setting

National map unit symbol: 227z
Elevation: 150 to 400 feet
Mean annual precipitation: 40 to 50 inches
Mean annual air temperature: 52 to 54 degrees F
Frost-free period: 165 to 210 days
Farmland classification: All areas are prime farmland

Map Unit Composition

Woodburn and similar soils: 90 percent
Minor components: 4 percent
Estimates are based on observations, descriptions, and transects of the mapunit.

Description of Woodburn

Setting

Landform: Terraces
Landform position (three-dimensional): Tread
Down-slope shape: Linear
Across-slope shape: Linear
Parent material: Stratified glaciolacustrine deposits

Typical profile

H1 - 0 to 16 inches: silt loam
H2 - 16 to 38 inches: silty clay loam
H3 - 38 to 60 inches: silt loam

Properties and qualities

Slope: 3 to 8 percent
Depth to restrictive feature: More than 80 inches
Drainage class: Moderately well drained
Capacity of the most limiting layer to transmit water (Ksat): Moderately low to moderately high (0.06 to 0.20 in/hr)
Depth to water table: About 25 to 32 inches
Frequency of flooding: None

Custom Soil Resource Report

Frequency of ponding: None
Available water capacity: High (about 12.0 inches)

Interpretive groups

Land capability classification (irrigated): 2e
Land capability classification (nonirrigated): 2e
Hydrologic Soil Group: C
Forage suitability group: Moderately Well Drained < 15% Slopes (G002XY004OR)
Other vegetative classification: Moderately Well Drained < 15% Slopes
(G002XY004OR)
Hydric soil rating: No

Minor Components

Huberly

Percent of map unit: 2 percent
Landform: Swales on terraces
Landform position (three-dimensional): Tread
Down-slope shape: Linear
Across-slope shape: Linear
Other vegetative classification: Poorly Drained (G002XY006OR)
Hydric soil rating: Yes

Dayton

Percent of map unit: 1 percent
Landform: Terraces
Landform position (three-dimensional): Tread
Down-slope shape: Linear
Across-slope shape: Linear
Other vegetative classification: Poorly Drained (G002XY006OR)
Hydric soil rating: Yes

Aquolls

Percent of map unit: 1 percent
Landform: Flood plains
Hydric soil rating: Yes

Soil Information for All Uses

Soil Properties and Qualities

The Soil Properties and Qualities section includes various soil properties and qualities displayed as thematic maps with a summary table for the soil map units in the selected area of interest. A single value or rating for each map unit is generated by aggregating the interpretive ratings of individual map unit components. This aggregation process is defined for each property or quality.

Soil Qualities and Features

Soil qualities are behavior and performance attributes that are not directly measured, but are inferred from observations of dynamic conditions and from soil properties. Example soil qualities include natural drainage, and frost action. Soil features are attributes that are not directly part of the soil. Example soil features include slope and depth to restrictive layer. These features can greatly impact the use and management of the soil.

Hydrologic Soil Group

Hydrologic soil groups are based on estimates of runoff potential. Soils are assigned to one of four groups according to the rate of water infiltration when the soils are not protected by vegetation, are thoroughly wet, and receive precipitation from long-duration storms.

The soils in the United States are assigned to four groups (A, B, C, and D) and three dual classes (A/D, B/D, and C/D). The groups are defined as follows:

Group A. Soils having a high infiltration rate (low runoff potential) when thoroughly wet. These consist mainly of deep, well drained to excessively drained sands or gravelly sands. These soils have a high rate of water transmission.

Group B. Soils having a moderate infiltration rate when thoroughly wet. These consist chiefly of moderately deep or deep, moderately well drained or well drained soils that have moderately fine texture to moderately coarse texture. These soils have a moderate rate of water transmission.

Custom Soil Resource Report

Group C. Soils having a slow infiltration rate when thoroughly wet. These consist chiefly of soils having a layer that impedes the downward movement of water or soils of moderately fine texture or fine texture. These soils have a slow rate of water transmission.

Group D. Soils having a very slow infiltration rate (high runoff potential) when thoroughly wet. These consist chiefly of clays that have a high shrink-swell potential, soils that have a high water table, soils that have a claypan or clay layer at or near the surface, and soils that are shallow over nearly impervious material. These soils have a very slow rate of water transmission.

If a soil is assigned to a dual hydrologic group (A/D, B/D, or C/D), the first letter is for drained areas and the second is for undrained areas. Only the soils that in their natural condition are in group D are assigned to dual classes.

Custom Soil Resource Report
Map—Hydrologic Soil Group

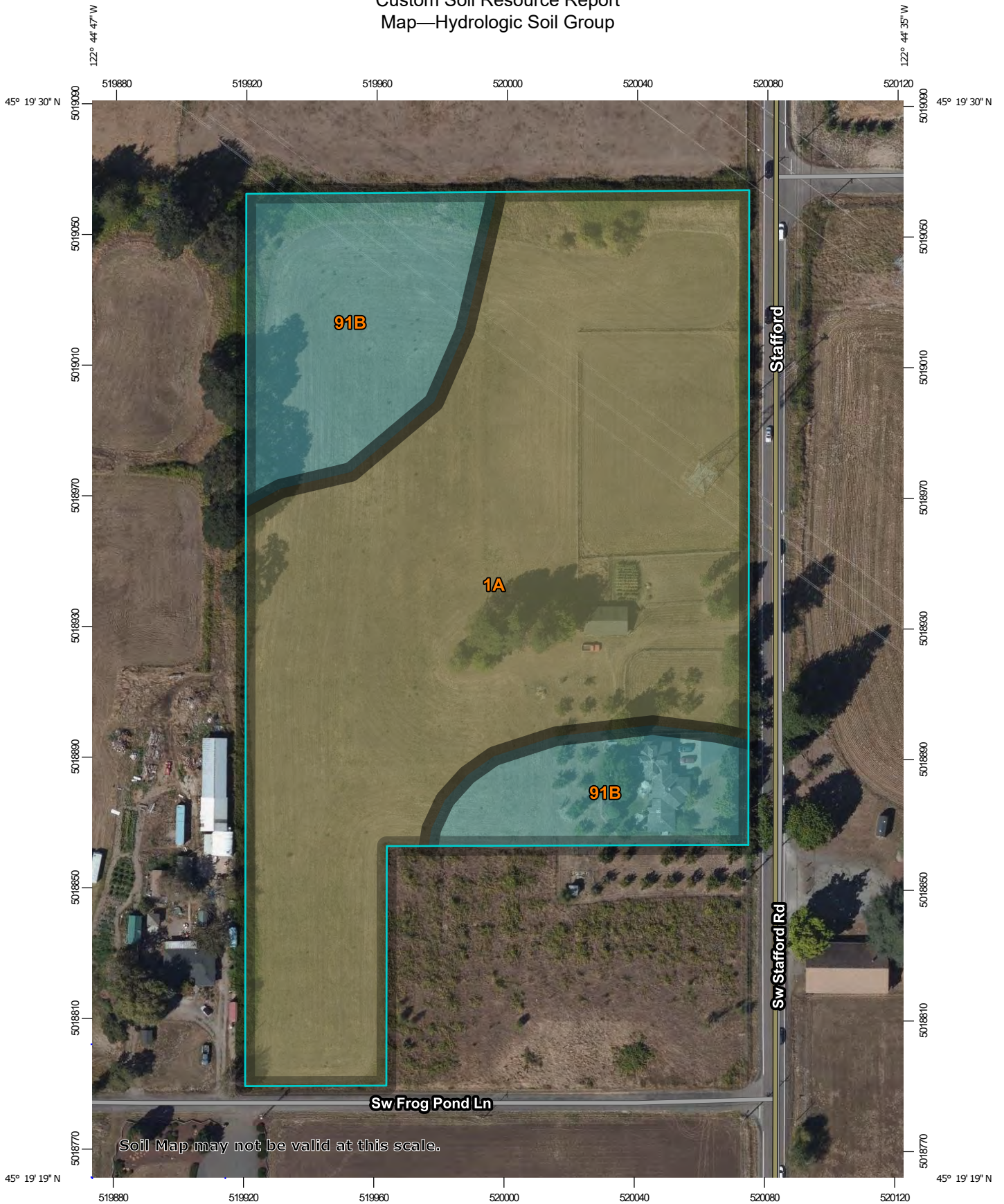

Map Scale: 1:1,610 if printed on A portrait (8.5" x 11") sheet.



Map projection: Web Mercator Corner coordinates: WGS84 Edge tics: UTM Zone 10N WGS84

MAP LEGEND

Area of Interest (AOI)









 Area of Interest (AOI)

Soils

Soil Rating Polygons





-  A
-  A/D
-  B
-  B/D
-  C
-  C/D
-  D
-  Not rated or not available

Soil Rating Lines

-  A
-  A/D
-  B
-  B/D
-  C
-  C/D
-  D
-  Not rated or not available

Soil Rating Points





-  A
-  A/D
-  B
-  B/D

-  C
-  C/D
-  D
-  Not rated or not available

Water Features

 Streams and Canals

Transportation

-  Rails
-  Interstate Highways
-  US Routes
-  Major Roads
-  Local Roads

Background

 Aerial Photography

MAP INFORMATION

The soil surveys that comprise your AOI were mapped at 1:20,000.

Warning: Soil Map may not be valid at this scale.

Enlargement of maps beyond the scale of mapping can cause misunderstanding of the detail of mapping and accuracy of soil line placement. The maps do not show the small areas of contrasting soils that could have been shown at a more detailed scale.

Please rely on the bar scale on each map sheet for map measurements.

Source of Map: Natural Resources Conservation Service
 Web Soil Survey URL:
 Coordinate System: Web Mercator (EPSG:3857)

Maps from the Web Soil Survey are based on the Web Mercator projection, which preserves direction and shape but distorts distance and area. A projection that preserves area, such as the Albers equal-area conic projection, should be used if more accurate calculations of distance or area are required.

This product is generated from the USDA-NRCS certified data as of the version date(s) listed below.

Soil Survey Area: Clackamas County Area, Oregon
 Survey Area Data: Version 16, Jun 11, 2020

Soil map units are labeled (as space allows) for map scales 1:50,000 or larger.

Date(s) aerial images were photographed: Aug 1, 2019—Sep 12, 2019

The orthophoto or other base map on which the soil lines were compiled and digitized probably differs from the background imagery displayed on these maps. As a result, some minor shifting of map unit boundaries may be evident.

Table—Hydrologic Soil Group

Map unit symbol	Map unit name	Rating	Acres in AOI	Percent of AOI
1A	Aloha silt loam, 0 to 3 percent slopes	C/D	6.3	75.0%
91B	Woodburn silt loam, 3 to 8 percent slopes	C	2.1	25.0%
Totals for Area of Interest			8.5	100.0%

Rating Options—Hydrologic Soil Group

Aggregation Method: Dominant Condition

Component Percent Cutoff: None Specified

Tie-break Rule: Higher

References

- American Association of State Highway and Transportation Officials (AASHTO). 2004. Standard specifications for transportation materials and methods of sampling and testing. 24th edition.
- American Society for Testing and Materials (ASTM). 2005. Standard classification of soils for engineering purposes. ASTM Standard D2487-00.
- Cowardin, L.M., V. Carter, F.C. Golet, and E.T. LaRoe. 1979. Classification of wetlands and deep-water habitats of the United States. U.S. Fish and Wildlife Service FWS/OBS-79/31.
- Federal Register. July 13, 1994. Changes in hydric soils of the United States.
- Federal Register. September 18, 2002. Hydric soils of the United States.
- Hurt, G.W., and L.M. Vasilas, editors. Version 6.0, 2006. Field indicators of hydric soils in the United States.
- National Research Council. 1995. Wetlands: Characteristics and boundaries.
- Soil Survey Division Staff. 1993. Soil survey manual. Soil Conservation Service. U.S. Department of Agriculture Handbook 18. http://www.nrcs.usda.gov/wps/portal/nrcs/detail/national/soils/?cid=nrcs142p2_054262
- Soil Survey Staff. 1999. Soil taxonomy: A basic system of soil classification for making and interpreting soil surveys. 2nd edition. Natural Resources Conservation Service, U.S. Department of Agriculture Handbook 436. http://www.nrcs.usda.gov/wps/portal/nrcs/detail/national/soils/?cid=nrcs142p2_053577
- Soil Survey Staff. 2010. Keys to soil taxonomy. 11th edition. U.S. Department of Agriculture, Natural Resources Conservation Service. http://www.nrcs.usda.gov/wps/portal/nrcs/detail/national/soils/?cid=nrcs142p2_053580
- Tiner, R.W., Jr. 1985. Wetlands of Delaware. U.S. Fish and Wildlife Service and Delaware Department of Natural Resources and Environmental Control, Wetlands Section.
- United States Army Corps of Engineers, Environmental Laboratory. 1987. Corps of Engineers wetlands delineation manual. Waterways Experiment Station Technical Report Y-87-1.
- United States Department of Agriculture, Natural Resources Conservation Service. National forestry manual. http://www.nrcs.usda.gov/wps/portal/nrcs/detail/soils/home/?cid=nrcs142p2_053374
- United States Department of Agriculture, Natural Resources Conservation Service. National range and pasture handbook. <http://www.nrcs.usda.gov/wps/portal/nrcs/detail/national/landuse/rangepasture/?cid=stelprdb1043084>

Custom Soil Resource Report

United States Department of Agriculture, Natural Resources Conservation Service. National soil survey handbook, title 430-VI. http://www.nrcs.usda.gov/wps/portal/nrcs/detail/soils/scientists/?cid=nrcs142p2_054242

United States Department of Agriculture, Natural Resources Conservation Service. 2006. Land resource regions and major land resource areas of the United States, the Caribbean, and the Pacific Basin. U.S. Department of Agriculture Handbook 296. http://www.nrcs.usda.gov/wps/portal/nrcs/detail/national/soils/?cid=nrcs142p2_053624

United States Department of Agriculture, Soil Conservation Service. 1961. Land capability classification. U.S. Department of Agriculture Handbook 210. http://www.nrcs.usda.gov/Internet/FSE_DOCUMENTS/nrcs142p2_052290.pdf

Appendix H: Relevant Information



2015

**STORMWATER & SURFACE WATER
DESIGN & CONSTRUCTION STANDARDS**

SECTION 3 - PUBLIC WORKS STANDARDS



**Community Development Department
29799 SW Town Center Loop E
Wilsonville, OR 97070**

Revised December 2015

allowable maximum density to use in the upstream basin analysis for ultimate development potential and conveyance system sizing.

301.1.12 Extension of Public Storm Sewer Systems

- a. The extension or upsizing of the public stormwater systems in excess of 12 inches in diameter (or equivalent flows) or as shown in the Wilsonville Stormwater Master Plan to serve the ultimate development density of the contributing area shall be done by the property owner or permit applicant and may be subject to applicable System Development Charge (SDC) credits.
- b. The City reserves the right to perform the work or cause it to be performed and bill the owner for the cost of the work or to pursue special assessment proceedings.
- c. The public storm sewer system shall extend to the most distant parcel boundary and be designed at a size and grade to facilitate future extension to serve development of the entire contributing area.
- d. Where public infrastructure improvements paid for by the property owner or permit applicant directly benefit adjacent properties, the property owner or permit applicant may pursue establishment of a reimbursement district per Section 3.116 of the City Code.
- e. The City's authorized representative may require a storm pipeline that serves or may serve more than one property to be a public system.

301.1.13 Conveyance System Hydraulic Standards

- a. The conveyance system shall be designed to convey and contain at least the peak runoff for the 25-year design storm.
- b. Structures for proposed pipe systems must be demonstrated to provide a minimum of 1 foot of freeboard between the hydraulic grade line and the top of the structure or finish grade above pipe for the 25-year post-development peak rate of runoff.
- c. Design surcharge in new pipe systems shall not be allowed if it will cause flooding in a habitable structure, including below-floor crawl spaces.
- d. The 25-year design shall be supplemented with an overland conveyance component demonstrating how a 100-year event will be accommodated. The overland component shall not be allowed to flow through or inundate an existing building.
- e. Flows in streets during the 25-year event shall not run deeper than 4 inches against the curb or extend more than 2 feet into the travel lane.
- f. Open channel systems shall be designed for minimum 1-foot freeboard from bank full, provided that no structures are impacted by the design water surface elevation.

301.1.14 Storm Systems and Fish Passage

For pipe systems that convey flows from a stream or through sensitive areas, a local representative of ODFW or other applicable state or federal agency shall be contacted to

Protecting undisturbed, uncompacted areas from construction activities provides more rainfall interception, evapo-transpiration and runoff rate attenuation than clearing and replanting, even with soil amendments. On the Preliminary Site Plan, identify areas that will not be cleared during construction.

(c) Minimize Soil Compaction

Avoid any construction activity that could cause soil compaction in areas designated for stormwater management facilities to preserve filtration and infiltration characteristics of the soil. Also avoid soil compaction in natural resource areas, and mitigation and/or re-vegetation areas. Delineate these areas on the Preliminary Site Plan and protect them during construction with orange construction fencing.

(d) Minimize Imperviousness

Complete and attach the Impervious Area Threshold Determination Form. The form allows for impervious area reduction credits for use of porous pavement, green roofs, tree preservation and tree planting (tree credits apply to non-single family developments only). Identify proposed impervious area reduction methods, and show them on the Preliminary Site Plan.

4. Proposed Stormwater Management Strategy

Given suitable site and soil conditions, the City requires that development shall incorporate LID facilities to infiltrate stormwater runoff to the Maximum Extent Practicable (MEP) to recharge groundwater and mimic pre-development hydrologic conditions. LID facilities will be designed and sized according to the soil classification and/or infiltration testing rate. Onsite soil characteristics may require a geotechnical report to address soil conditions, infiltration rates and groundwater to incorporate an infiltration strategy into the stormwater management plan to the MEP.

For the *Site Assessment and Planning Checklist*, the applicant must identify and select a proposed stormwater management strategy from the choices below.

- (a) LID facilities to the MEP – Check this option if LID facilities will be utilized to the MEP to address the water quality and flow control requirements of the site. LID facilities must be sized according to the design requirements in [Section 301.4.00](#), “Stormwater Management Facility Selection and Design” utilizing either the BMP Sizing Tool or the Engineered Method. MEP is defined as installing LID facilities with a surface area of at least 10% of the total new or redeveloped impervious area. Approved stormwater management facilities that qualify as LID facilities are defined in [Section 301.4.00](#).
- (b) Onsite retention of the 10-year design storm – Where possible, retain and infiltrate all stormwater runoff up to and including the 10-year storm onsite using LID facilities. Infiltration of the full 10-year design storm is assumed to satisfy both water quality and flow control requirements of [Section 301.4.00](#), “Stormwater Management Facility Selection and Design”.

- (c) Limiting conditions for LID facilities - The following limiting conditions restrict the practicality of using onsite infiltration and may require the use of lined, non-infiltrating stormwater management facilities or underground facilities to meet stormwater management requirements. When sites have limiting conditions, a report is required to document one of the following:
- (1) Stormwater management facilities will be located on fill.
 - (2) Site areas with steep slopes ($\geq 20\%$) and/or slope stability concerns (geotechnical engineering or geologist report and City approval required for infiltration facilities on moderate slopes of 10-20%).
 - (3) Sites in areas of seasonal high groundwater table (for site planning submittal, sites with jurisdictional wetlands or FEMA floodplains may be required to perform a seasonal high groundwater table assessment and determine that the seasonal groundwater table is below the proposed bottom elevation of stormwater infiltration facilities).
 - (4) Sites with contaminated soils (sites that have contaminated soils conditions must be evaluated by the Oregon Department of Environmental Quality (ODEQ) and/or the Environmental Protection Agency to determine if areas on the property are suitable for infiltration without the risk of mobilizing contaminants in the soil or groundwater. Documentation showing contamination assessment and determination must be submitted to the City at the time of application).
 - (5) There is a conflict with required source controls for high-risk sites (a geotechnical report is not required to document this limiting condition, but approval from the City is required to install lined and/or underground facilities in place of LID facilities).

5. Facility Selection/Sizing

After selecting a stormwater management strategy, applicants shall indicate which stormwater management facilities are proposed for the site based on the results of the site assessment and planning process. The BMP Sizing Tool shall be used to calculate the size of the facilities and the BMP Sizing Tool report shall be included as part of the application. All proposed impervious area reduction methods and proposed stormwater management facilities shall be shown on the Preliminary Site Plan.

301.3.00 SUBMITTAL REQUIREMENTS

The Developer's engineer shall submit sufficient supporting information as outlined below to justify the proposed stormwater management design meets all the provisions within these standards and the land use conditions of approval. It is the design engineer's responsibility to ensure that engineering plans are sufficiently clear and concise to construct the project in proper sequence, using specified methods and materials, with sufficient dimensions to fulfill the intent of these design standards. A Storm Drainage Report as outlined in [Section 301.3.02](#), "Storm Drainage Report", is required to be prepared and submitted with the design plans.

301.4.01 Impervious Area Used in Design

- a. Stormwater management facilities are required when proposed development establishes or increases the impervious surface area by more than 5,000 square feet. Development includes new development, redevelopment, and/or partial redevelopment.
- b. For single-family and duplex residential subdivisions, stormwater management facilities shall be sized for all impervious areas created by the subdivision, including all residences on individual lots at the current rate of 2,750 square feet of impervious surface area per dwelling unit.
- c. For all developments other than single-family and duplex dwellings, including row houses and condominiums, the sizing of stormwater management facilities shall be based on the impervious area to be created by the development, including structures and all roads and impervious areas. Impervious surfaces shall be based on building permits, construction plans, or other appropriate methods of measurement deemed reliable by the City's authorized representative.
- d. The City encourages design initiatives that reduce the effective impervious area. For developments other than single-family and duplex dwellings, a smaller stormwater management facility may be possible.

301.4.02 Criteria for Requiring a Stormwater Management Facility

A stormwater management facility shall be constructed on site unless, in the judgment of the City's authorized representative, any of the following conditions exist:

- a. The site location, size, gradient, topography, soils, or presence of an SROZ make it impractical or ineffective to construct an on-site facility.
- b. The subbasin has a more effective, existing regional site designed to incorporate the development or which has the capacity to treat the site stormwater.
- c. The development is for construction of one- or two-family (duplex) dwellings on existing lots of record which will establish or create less than 5,000 square feet of impervious surface.

301.4.03 Facility Selection

LID facilities such as planters, swales, rain gardens, ponds, and other vegetated facilities are the preferred strategy to meet the stormwater management requirements for water quality treatment and flow control. Impervious area reduction techniques, such as preservation of existing trees, retaining vegetation and open space, clustering buildings, disconnecting residential downspouts, and constructing pervious pavement and green roofs, may be used as techniques to help mitigate stormwater runoff and reduce the size of the required stormwater management facilities.

- a. The following types of stormwater management facilities can be used to meet these standards:
 1. Impervious Area Reduction Methods:

- c. **Alternate Facilities** - Applicants may propose stormwater management facilities that are not listed in **Table 3.10**. Such a proposal will require the applicant to submit a request for a modification to these standards. Alternate facilities must be sized using the Engineered Method as described in this section. An example of an alternate facility would be for the use of a drywell, infiltration trench, or other underground injection control (UIC) facility on private property. To propose a UIC on private property, the applicant would need to prepare appropriate registration information to ODEQ and submit a modification request to the City.

301.4.04 Design Criteria

Stormwater management facility design is based on meeting the City's design criteria to address LID requirements, water quality treatment standards, and flow control requirements.

- a. **LID to the MEP:** The goal is to prioritize the use of LID facilities to the MEP to mimic the natural stormwater runoff conditions of the pre-developed site and recharge the groundwater. The City's strategy to meet this goal is to incorporate LID principles in site planning and facility design.

Either one of the following two options may be used to meet the LID requirement:

1. **LID facilities to the MEP** – Utilize LID facilities to the MEP to address the water quality and flow control requirements of the site. LID facilities shall be sized according to the design requirements of this section, utilizing either the BMP Sizing Tool or the Engineered Method. When site constraints limit the surface area available for stormwater management facilities, MEP is defined as installing LID facilities with a surface area of at least 10% of the total new plus replaced impervious area.
 2. **Onsite Retention** – Retain and fully infiltrate the 10-year design storm on site using LID facilities. This is equivalent to retaining and infiltrating runoff from new impervious surface for the 3.4-inch storm over 24 hours. The facility shall fully infiltrate within 72 hours following the beginning of the storm event. Infiltration of the full 10-year design storm is assumed to satisfy both water quality and flow control requirements.
- b. **Limited Infiltration:** For sites with conditions that limit the use of infiltration (fill, steep slopes, high groundwater table, well-head protection areas, and/or contaminated soils), utilizing LID facilities may not be practicable and the applicant may use lined, non-infiltrating or underground stormwater management facilities. In such cases, the applicant shall submit documentation of limiting conditions from a geotechnical engineer or engineering geologist registered in the State of Oregon, or documentation from ODEQ.
 - c. **Water Quality Requirement:** Water quality facilities shall be designed to capture and treat 80% of the average annual runoff volume to the MEP with the goal of 70% total suspended solids (TSS) removal. In this context, MEP means less effective treatment may not be substituted when it is practicable to provide more effective treatment. The treatment volume equates to a design storm of 1.0 inch over 24 hours.

The BMP Sizing Tool addresses these water quality requirements to size stormwater management facilities.

Hydrodynamic separators, when used as a sole method of stormwater treatment, do not meet the MEP requirement for stormwater treatment effectiveness with regard to these stormwater standards.

- d. **Flow Control Requirement:** The duration of peak flow rates from post-development conditions shall be less than or equal to the duration of peak flow rates from pre-development conditions for all peak flows between 42% of the 2-year storm peak flow rate¹ up to the 10-year peak flow rate. A hydrologic/hydraulic analytical model capable of performing a continuous simulation of flows from local long-term rainfall data shall be used to determine the peak flow rates, recurrence intervals and durations. The BMP Sizing Tool incorporates these flow control requirements to size stormwater management facilities.

301.4.05 Design Methods

This section explains the two methods accepted by the City for designing stormwater management facilities: the BMP Sizing Tool Method and the Engineered Method. To use a different method for sizing a treatment facility type not covered in these standards, applicants shall obtain approval from the City's authorized representative prior to submitting permit applications for review.

a. BMP Sizing Tool Method:

1. A BMP Sizing Tool application is available from the City to assist with the sizing of stormwater management facilities that meet the requirements of these standards. The following facilities can be sized using the tool:
 - (a) Rain Garden – Infiltration and Filtration
 - (b) Stormwater Planter – Infiltration and Filtration
 - (c) Vegetated Swale - Infiltration and Filtration
 - (d) Infiltrator
 - (e) Detention Pond
2. The detention pond option will allow credit for the utilization of upstream LID facilities.
3. The report generated by the BMP Sizing Tool shall be included with permit application submittals. The BMP Sizing Tool can be used during the initial site

¹ The lower threshold of 42% of the 2-year peak flow rate for flow-duration matching is based on a 2008 study by the Oregon Department of Transportation (ODOT) titled, "Water Quantity (Flow Control) Design Storm Performance Standard." ODOT's study found that bed movement in sand-bedded streams occurs at approximately two-thirds of the bank full flow, which is assumed to be roughly equivalent to the 1.2 year discharge. ODOT's flow frequency analysis established that two thirds of the 1.2-year discharge is approximately equivalent to 42 percent of the 2-year discharge.

Table 2-2a Runoff curve numbers for urban areas ^{1/}

Cover description	Average percent impervious area ^{2/}	Curve numbers for hydrologic soil group			
		A	B	C	D
Fully developed urban areas (vegetation established)					
Open space (lawns, parks, golf courses, cemeteries, etc.) ^{3/} :					
Poor condition (grass cover < 50%)		68	79	86	89
Fair condition (grass cover 50% to 75%)		49	69	79	84
Good condition (grass cover > 75%)		39	61	74	80
Impervious areas:					
Paved parking lots, roofs, driveways, etc. (excluding right-of-way)		98	98	98	98
Streets and roads:					
Paved; curbs and storm sewers (excluding right-of-way)		98	98	98	98
Paved; open ditches (including right-of-way)		83	89	92	93
Gravel (including right-of-way)		76	85	89	91
Dirt (including right-of-way)		72	82	87	89
Western desert urban areas:					
Natural desert landscaping (pervious areas only) ^{4/}		63	77	85	88
Artificial desert landscaping (impervious weed barrier, desert shrub with 1- to 2-inch sand or gravel mulch and basin borders)		96	96	96	96
Urban districts:					
Commercial and business	85	89	92	94	95
Industrial	72	81	88	91	93
Residential districts by average lot size:					
1/8 acre or less (town houses)	65	77	85	90	92
1/4 acre	38	61	75	83	87
1/3 acre	30	57	72	81	86
1/2 acre	25	54	70	80	85
1 acre	20	51	68	79	84
2 acres	12	46	65	77	82

Developing urban areas

Newly graded areas
(pervious areas only, no vegetation) ^{5/}

	77	86	91	94
--	----	----	----	----

Idle lands (CN's are determined using cover types
similar to those in table 2-2c).

¹ Average runoff condition, and $I_a = 0.2S$.

² The average percent impervious area shown was used to develop the composite CN's. Other assumptions are as follows: impervious areas are directly connected to the drainage system, impervious areas have a CN of 98, and pervious areas are considered equivalent to open space in good hydrologic condition. CN's for other combinations of conditions may be computed using figure 2-3 or 2-4.

³ CN's shown are equivalent to those of pasture. Composite CN's may be computed for other combinations of open space cover type.

⁴ Composite CN's for natural desert landscaping should be computed using figures 2-3 or 2-4 based on the impervious area percentage (CN = 98) and the pervious area CN. The pervious area CN's are assumed equivalent to desert shrub in poor hydrologic condition.

⁵ Composite CN's to use for the design of temporary measures during grading and construction should be computed using figure 2-3 or 2-4 based on the degree of development (impervious area percentage) and the CN's for the newly graded pervious areas.

Table 2-2b Runoff curve numbers for cultivated agricultural lands ^{1/}

Cover description			Curve numbers for hydrologic soil group			
Cover type	Treatment ^{2/}	Hydrologic condition ^{3/}	A	B	C	D
Fallow	Bare soil	—	77	86	91	94
	Crop residue cover (CR)	Poor	76	85	90	93
		Good	74	83	88	90
Row crops	Straight row (SR)	Poor	72	81	88	91
		Good	67	78	85	89
	SR + CR	Poor	71	80	87	90
		Good	64	75	82	85
	Contoured (C)	Poor	70	79	84	88
		Good	65	75	82	86
	C + CR	Poor	69	78	83	87
		Good	64	74	81	85
	Contoured & terraced (C&T)	Poor	66	74	80	82
		Good	62	71	78	81
C&T+ CR	Poor	65	73	79	81	
	Good	61	70	77	80	
Small grain	SR	Poor	65	76	84	88
		Good	63	75	83	87
	SR + CR	Poor	64	75	83	86
		Good	60	72	80	84
	C	Poor	63	74	82	85
		Good	61	73	81	84
	C + CR	Poor	62	73	81	84
		Good	60	72	80	83
	C&T	Poor	61	72	79	82
		Good	59	70	78	81
	C&T+ CR	Poor	60	71	78	81
		Good	58	69	77	80
Close-seeded or broadcast legumes or rotation meadow	SR	Poor	66	77	85	89
		Good	58	72	81	85
	C	Poor	64	75	83	85
		Good	55	69	78	83
	C&T	Poor	63	73	80	83
		Good	51	67	76	80

¹ Average runoff condition, and $I_a=0.2S$

² Crop residue cover applies only if residue is on at least 5% of the surface throughout the year.

³ Hydraulic condition is based on combination factors that affect infiltration and runoff, including (a) density and canopy of vegetative areas, (b) amount of year-round cover, (c) amount of grass or close-seeded legumes, (d) percent of residue cover on the land surface (good $\geq 20\%$), and (e) degree of surface roughness.

Poor: Factors impair infiltration and tend to increase runoff.

Good: Factors encourage average and better than average infiltration and tend to decrease runoff.

Table 2-2c Runoff curve numbers for other agricultural lands ^{1/}

Cover description	Hydrologic condition	Curve numbers for hydrologic soil group			
		A	B	C	D
Pasture, grassland, or range—continuous forage for grazing. ^{2/}	Poor	68	79	86	89
	Fair	49	69	79	84
	Good	39	61	74	80
Meadow—continuous grass, protected from grazing and generally mowed for hay.	—	30	58	71	78
Brush—brush-weed-grass mixture with brush the major element. ^{3/}	Poor	48	67	77	83
	Fair	35	56	70	77
	Good	30 ^{4/}	48	65	73
Woods—grass combination (orchard or tree farm). ^{5/}	Poor	57	73	82	86
	Fair	43	65	76	82
	Good	32	58	72	79
Woods. ^{6/}	Poor	45	66	77	83
	Fair	36	60	73	79
	Good	30 ^{4/}	55	70	77
Farmsteads—buildings, lanes, driveways, and surrounding lots.	—	59	74	82	86

¹ Average runoff condition, and $I_a = 0.2S$.

² **Poor:** <50% ground cover or heavily grazed with no mulch.

Fair: 50 to 75% ground cover and not heavily grazed.

Good: > 75% ground cover and lightly or only occasionally grazed.

³ **Poor:** <50% ground cover.

Fair: 50 to 75% ground cover.

Good: >75% ground cover.

⁴ Actual curve number is less than 30; use CN = 30 for runoff computations.

⁵ CN's shown were computed for areas with 50% woods and 50% grass (pasture) cover. Other combinations of conditions may be computed from the CN's for woods and pasture.

⁶ **Poor:** Forest litter, small trees, and brush are destroyed by heavy grazing or regular burning.

Fair: Woods are grazed but not burned, and some forest litter covers the soil.

Good: Woods are protected from grazing, and litter and brush adequately cover the soil.

Table 2-2d Runoff curve numbers for arid and semiarid rangelands ^{1/}

Cover description		Curve numbers for hydrologic soil group			
Cover type	Hydrologic condition ^{2/}	A ^{3/}	B	C	D
Herbaceous—mixture of grass, weeds, and low-growing brush, with brush the minor element.	Poor		80	87	93
	Fair		71	81	89
	Good		62	74	85
Oak-aspen—mountain brush mixture of oak brush, aspen, mountain mahogany, bitter brush, maple, and other brush.	Poor		66	74	79
	Fair		48	57	63
	Good		30	41	48
Pinyon-juniper—pinyon, juniper, or both; grass understory.	Poor		75	85	89
	Fair		58	73	80
	Good		41	61	71
Sagebrush with grass understory.	Poor		67	80	85
	Fair		51	63	70
	Good		35	47	55
Desert shrub—major plants include saltbush, greasewood, creosotebush, blackbrush, bursage, palo verde, mesquite, and cactus.	Poor	63	77	85	88
	Fair	55	72	81	86
	Good	49	68	79	84

¹ Average runoff condition, and $I_a = 0.2S$. For range in humid regions, use table 2-2c.

² Poor: <30% ground cover (litter, grass, and brush overstory).

Fair: 30 to 70% ground cover.

Good: > 70% ground cover.

³ Curve numbers for group A have been developed only for desert shrub.

Appendix I: Downstream Analysis

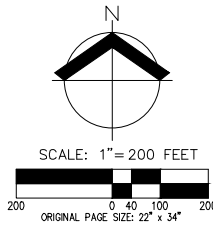

AKS
 AKS ENGINEERING & FORESTRY, LLC
 12345 SW HERMAN RD, STE 100
 TUALATIN, OR 97062
 503-563-6151
 WWW.AKS-ENG.COM
 ENGINEERING • SURVEYING • NATURAL RESOURCES
 FORESTRY • PLANNING • LANDSCAPE ARCHITECTURE

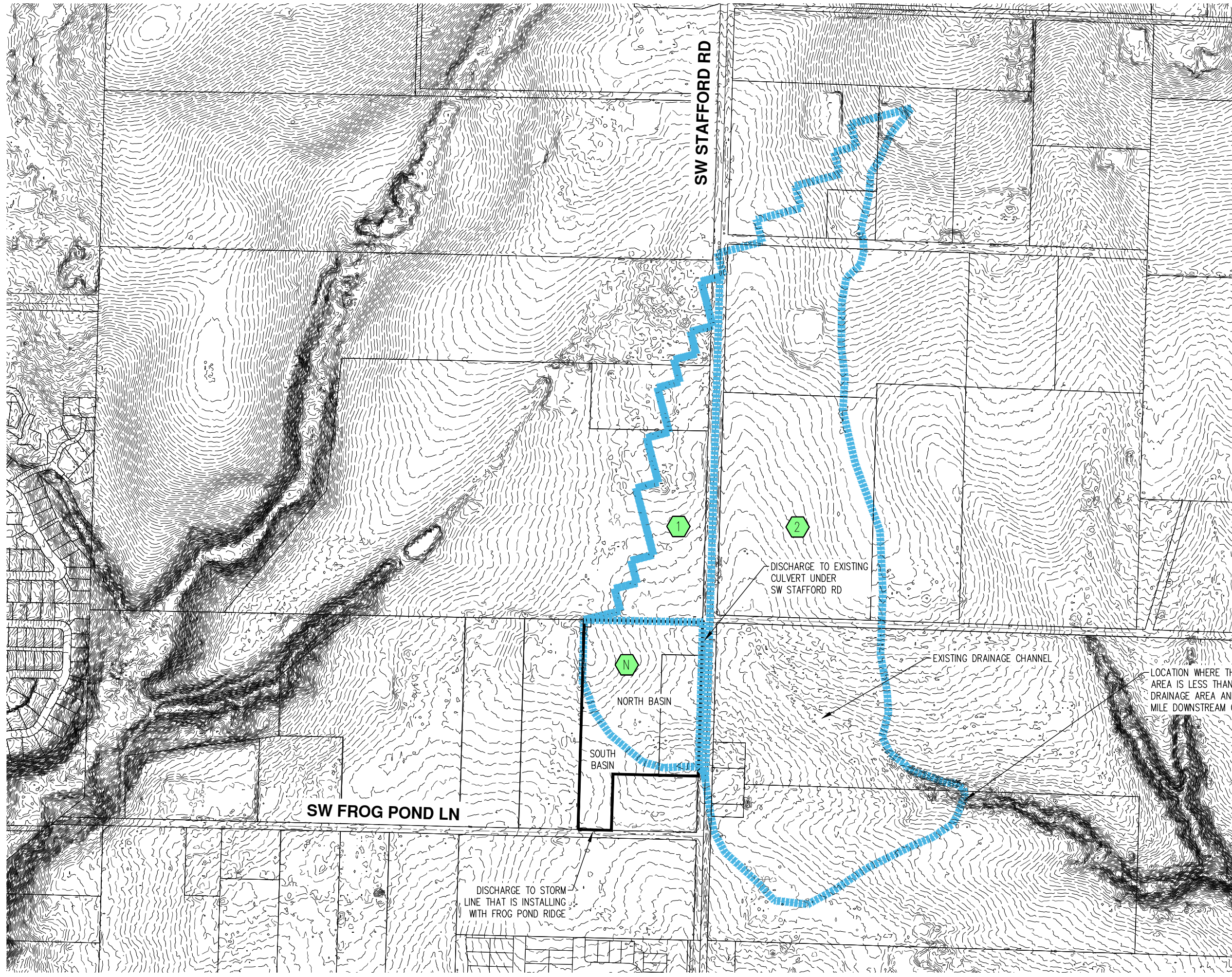

**DOWNSTREAM BASIN MAP
 FROG POND CROSSING
 VENTURE PROPERTIES, INC.
 WILSONVILLE, OREGON**

**PRELIMINARY
 NOT FOR
 CONSTRUCTION**

JOB NUMBER:	5252
DATE:	08/26/2021
DESIGNED BY:	AJD
DRAWN BY:	NLB
CHECKED BY:	MD

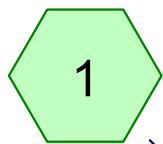

Basin

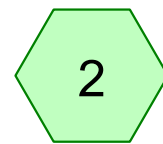

Basin

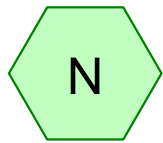

Basin

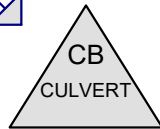

EXISTING CULVERT
UNDER SW
STAFFORD RD

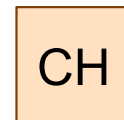

EXISTING DRAINAGE
CHANNEL

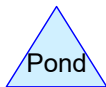
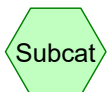
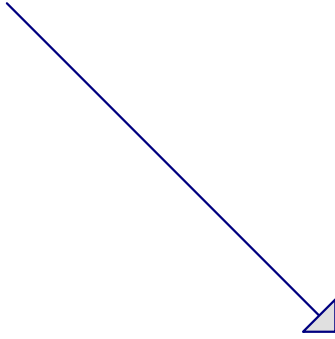

Routing Diagram for 5252 HydroCAD Downstream
Prepared by AKS Engineering & Forestry, LLC, Printed 11/8/2021
HydroCAD® 10.00-22 s/n 01338 © 2018 HydroCAD Software Solutions LLC

5252 HydroCAD Downstream

Prepared by AKS Engineering & Forestry, LLC
HydroCAD® 10.00-22 s/n 01338 © 2018 HydroCAD Software Solutions LLC

Printed 11/8/2021

Area Listing (all nodes)

Area (sq-ft)	CN	Description (subcatchment-numbers)
214,577	98	Impervious (1, 2, N)
2,318,263	71	Pervious (1, 2)
67,126	86	Pervious (N)

5252 HydroCAD Downstream

Prepared by AKS Engineering & Forestry, LLC
HydroCAD® 10.00-22 s/n 01338 © 2018 HydroCAD Software Solutions LLC

Printed 11/8/2021

Pipe Listing (all nodes)

Line#	Node Number	In-Invert (feet)	Out-Invert (feet)	Length (feet)	Slope (ft/ft)	n	Diam/Width (inches)	Height (inches)	Inside-Fill (inches)
1	CULVERT	238.67	238.18	39.6	0.0124	0.013	15.0	0.0	0.0

5252 HydroCAD Downstream

Prepared by AKS Engineering & Forestry, LLC
HydroCAD® 10.00-22 s/n 01338 © 2018 HydroCAD Software Solutions LLC

Printed 11/8/2021

Notes Listing (all nodes)

Line#	Node Number	Notes
1	CULVERT	ROAD CL: 242.5±

5252 HydroCAD Downstream

Prepared by AKS Engineering & Forestry, LLC

HydroCAD® 10.00-22 s/n 01338 © 2018 HydroCAD Software Solutions LLC

Type IA 24-hr 25-YR Rainfall=3.90"

Printed 11/8/2021

Time span=0.00-24.00 hrs, dt=0.10 hrs, 241 points

Runoff by SBUH method, Split Pervious/Imperv.

Reach routing by Stor-Ind+Trans method - Pond routing by Stor-Ind method

Subcatchment1: Basin

Runoff Area=8.500 ac 4.82% Impervious Runoff Depth>1.42"
Flow Length=300' Slope=0.0250 '/' Tc=21.4 min CN=71/98 Runoff=1.81 cfs 43,829 cf

Subcatchment2: Basin

Runoff Area=47.500 ac 4.99% Impervious Runoff Depth>1.40"
Flow Length=2,400' Tc=51.6 min CN=71/98 Runoff=7.02 cfs 240,825 cf

SubcatchmentN: Basin

Runoff Area=3.687 ac 58.20% Impervious Runoff Depth>3.15"
Tc=10.0 min CN=86/98 Runoff=2.75 cfs 42,132 cf

Reach CH: EXISTING DRAINAGE CHANNEL

Avg. Flow Depth=0.51' Max Vel=2.95 fps Inflow=11.00 cfs 326,787 cf
n=0.030 L=1,300.0' S=0.0180 '/' Capacity=53.08 cfs Outflow=10.67 cfs 323,349 cf

Pond CULVERT: EXISTING CULVERT UNDER SW STAFFORD RD

Peak Elev=239.86' Inflow=4.48 cfs 85,961 cf
15.0" Round Culvert n=0.013 L=39.6' S=0.0124 '/' Outflow=4.48 cfs 85,961 cf

5252 HydroCAD Downstream

Prepared by AKS Engineering & Forestry, LLC
 HydroCAD® 10.00-22 s/n 01338 © 2018 HydroCAD Software Solutions LLC

Type IA 24-hr 25-YR Rainfall=3.90"

Printed 11/8/2021

Summary for Subcatchment 1: Basin

Runoff = 1.81 cfs @ 8.11 hrs, Volume= 43,829 cf, Depth> 1.42"

Runoff by SBUH method, Split Pervious/Imperv., Time Span= 0.00-24.00 hrs, dt= 0.10 hrs
 Type IA 24-hr 25-YR Rainfall=3.90"

Area (ac)	CN	Description
* 0.410	98	Impervious
* 8.090	71	Pervious
8.500	72	Weighted Average
8.090		95.18% Pervious Area
0.410		4.82% Impervious Area

Tc (min)	Length (feet)	Slope (ft/ft)	Velocity (ft/sec)	Capacity (cfs)	Description
21.4	300	0.0250	0.23		Sheet Flow, Range n= 0.130 P2= 2.60"

Subcatchment 1: Basin

Hydrograph

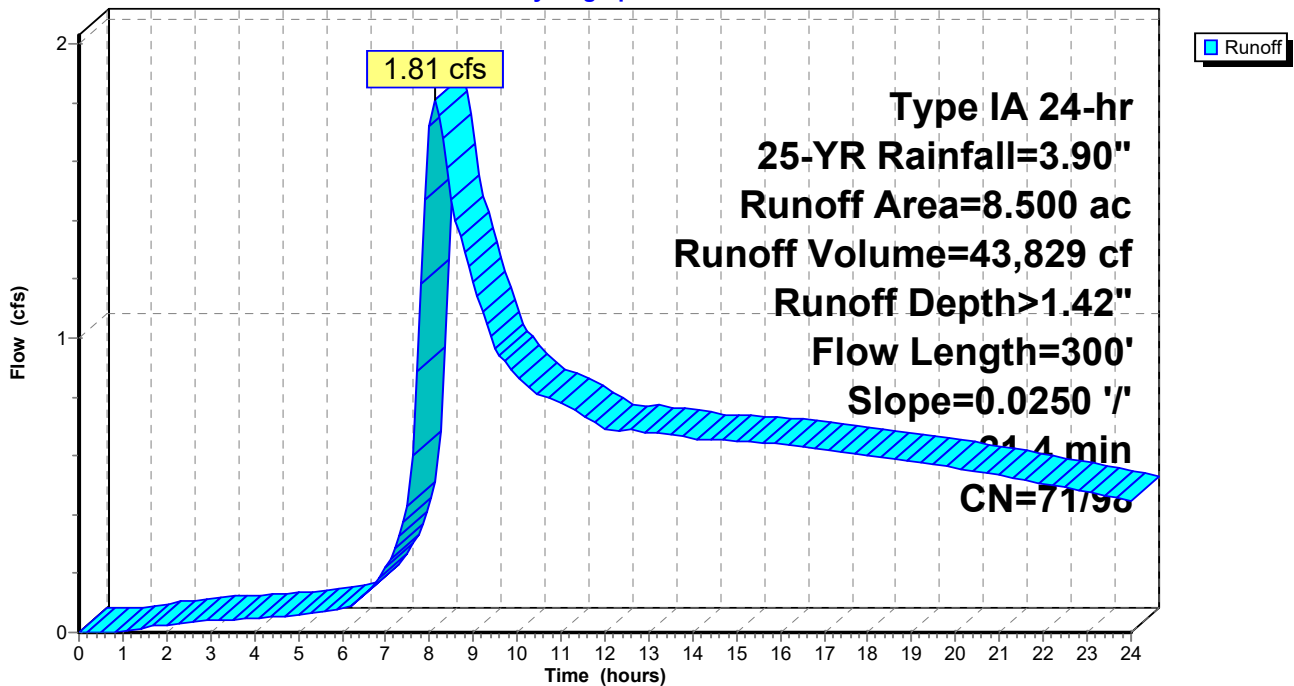

5252 HydroCAD Downstream

Prepared by AKS Engineering & Forestry, LLC
 HydroCAD® 10.00-22 s/n 01338 © 2018 HydroCAD Software Solutions LLC

Type IA 24-hr 25-YR Rainfall=3.90"

Printed 11/8/2021

Summary for Subcatchment 2: Basin

Runoff = 7.02 cfs @ 8.37 hrs, Volume= 240,825 cf, Depth> 1.40"

Runoff by SBUH method, Split Pervious/Imperv., Time Span= 0.00-24.00 hrs, dt= 0.10 hrs
 Type IA 24-hr 25-YR Rainfall=3.90"

Area (ac)	CN	Description
* 2.370	98	Impervious
* 45.130	71	Pervious
47.500	72	Weighted Average
45.130		95.01% Pervious Area
2.370		4.99% Impervious Area

Tc (min)	Length (feet)	Slope (ft/ft)	Velocity (ft/sec)	Capacity (cfs)	Description
16.2	300	0.0500	0.31		Sheet Flow, Range n= 0.130 P2= 2.60"
35.4	2,100	0.0200	0.99		Shallow Concentrated Flow, Short Grass Pasture Kv= 7.0 fps
51.6	2,400	Total			

Subcatchment 2: Basin

Hydrograph

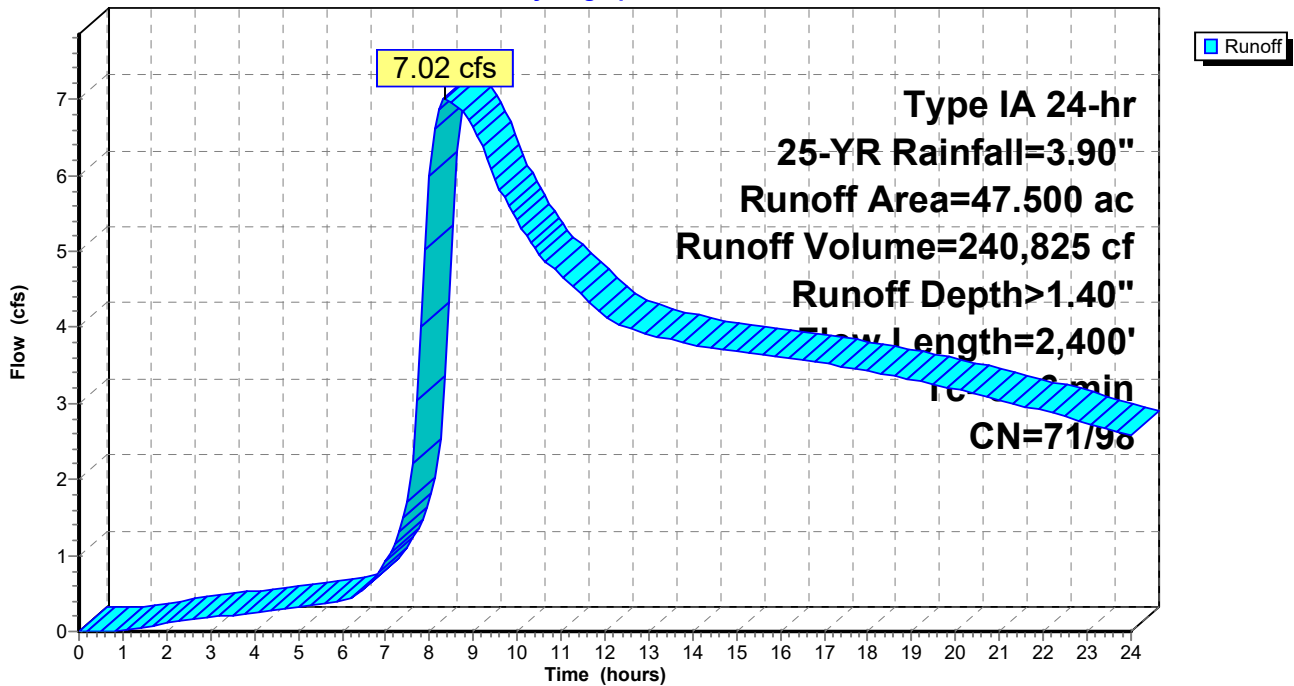

5252 HydroCAD Downstream

Prepared by AKS Engineering & Forestry, LLC
HydroCAD® 10.00-22 s/n 01338 © 2018 HydroCAD Software Solutions LLC

Type IA 24-hr 25-YR Rainfall=3.90"

Printed 11/8/2021

Summary for Subcatchment N: Basin

Runoff = 2.75 cfs @ 7.98 hrs, Volume= 42,132 cf, Depth> 3.15"

Runoff by SBUH method, Split Pervious/Imperv., Time Span= 0.00-24.00 hrs, dt= 0.10 hrs
Type IA 24-hr 25-YR Rainfall=3.90"

Area (ac)	CN	Description
* 2.146	98	Impervious
* 1.541	86	Pervious
3.687	93	Weighted Average
1.541		41.80% Pervious Area
2.146		58.20% Impervious Area

Tc (min)	Length (feet)	Slope (ft/ft)	Velocity (ft/sec)	Capacity (cfs)	Description
10.0					Direct Entry,

Subcatchment N: Basin

Hydrograph

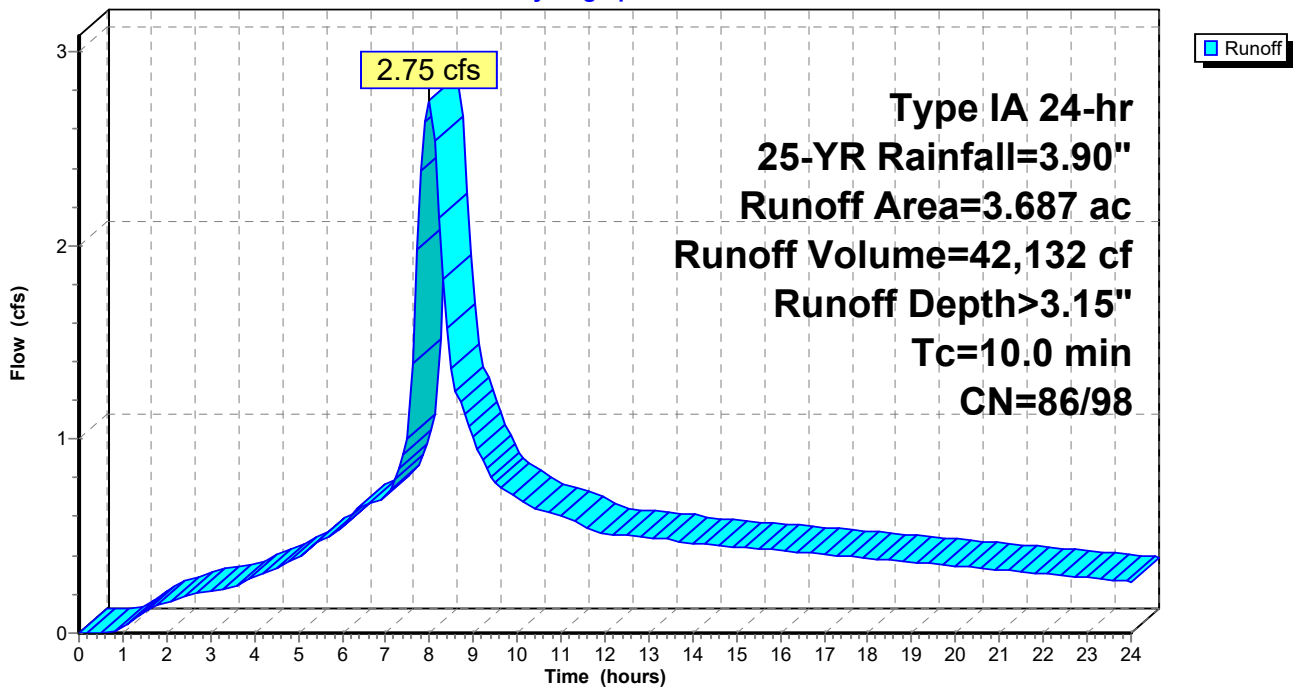

5252 HydroCAD Downstream

Prepared by AKS Engineering & Forestry, LLC
HydroCAD® 10.00-22 s/n 01338 © 2018 HydroCAD Software Solutions LLC

Type IA 24-hr 25-YR Rainfall=3.90"

Printed 11/8/2021

Summary for Pond CULVERT: EXISTING CULVERT UNDER SW STAFFORD RD

ROAD CL: 242.5±

Inflow Area = 530,866 sf, 20.97% Impervious, Inflow Depth > 1.94" for 25-YR event
Inflow = 4.48 cfs @ 8.03 hrs, Volume= 85,961 cf
Outflow = 4.48 cfs @ 8.03 hrs, Volume= 85,961 cf, Atten= 0%, Lag= 0.0 min
Primary = 4.48 cfs @ 8.03 hrs, Volume= 85,961 cf

Routing by Stor-Ind method, Time Span= 0.00-24.00 hrs, dt= 0.10 hrs
Peak Elev= 239.86' @ 8.03 hrs

Device	Routing	Invert	Outlet Devices
#1	Primary	238.67'	15.0" Round Culvert L= 39.6' RCP, end-section conforming to fill, Ke= 0.500 Inlet / Outlet Invert= 238.67' / 238.18' S= 0.0124 '/ Cc= 0.900 n= 0.013, Flow Area= 1.23 sf

Primary OutFlow Max=4.44 cfs @ 8.03 hrs HW=239.85' (Free Discharge)
↑1=Culvert (Barrel Controls 4.44 cfs @ 4.76 fps)

Pond CULVERT: EXISTING CULVERT UNDER SW STAFFORD RD

Hydrograph

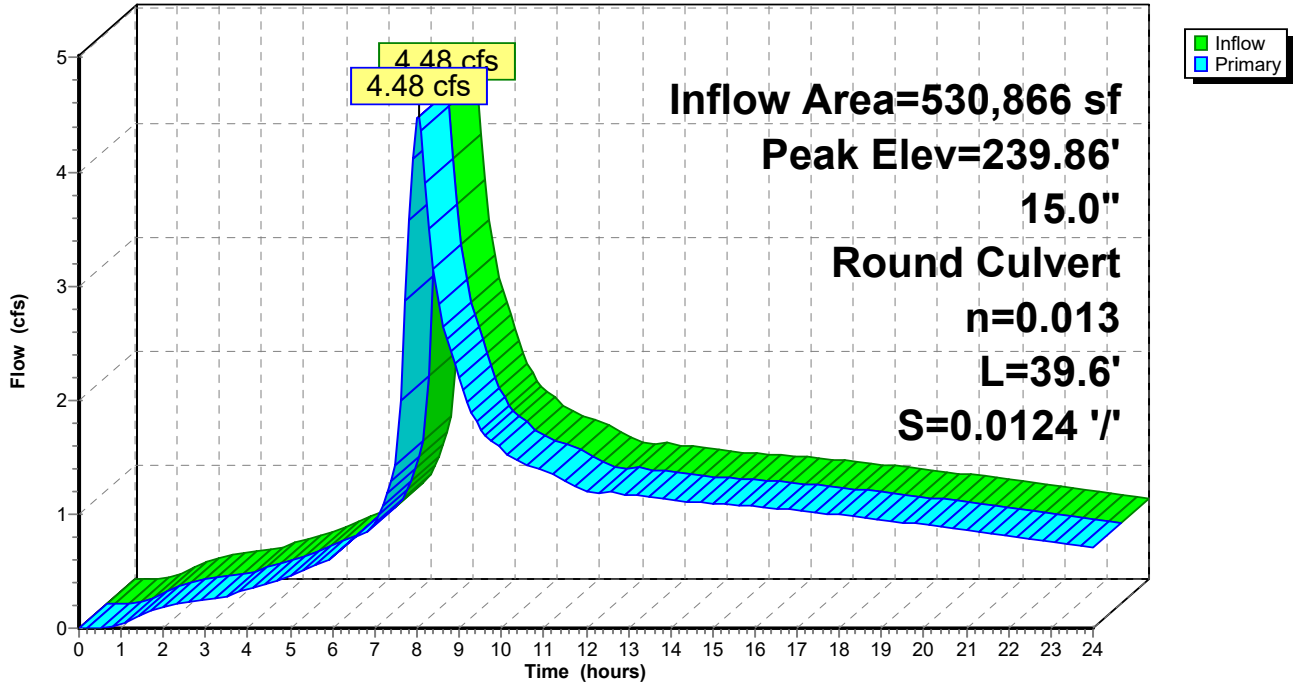

5252 HydroCAD Downstream

Prepared by AKS Engineering & Forestry, LLC
HydroCAD® 10.00-22 s/n 01338 © 2018 HydroCAD Software Solutions LLC

Type IA 24-hr 25-YR Rainfall=3.90"

Printed 11/8/2021

Summary for Reach CH: EXISTING DRAINAGE CHANNEL

Inflow Area = 2,599,966 sf, 8.25% Impervious, Inflow Depth > 1.51" for 25-YR event
Inflow = 11.00 cfs @ 8.12 hrs, Volume= 326,787 cf
Outflow = 10.67 cfs @ 8.38 hrs, Volume= 323,349 cf, Atten= 3%, Lag= 15.5 min

Routing by Stor-Ind+Trans method, Time Span= 0.00-24.00 hrs, dt= 0.10 hrs
Max. Velocity= 2.95 fps, Min. Travel Time= 7.3 min
Avg. Velocity= 2.09 fps, Avg. Travel Time= 10.4 min

Peak Storage= 4,726 cf @ 8.24 hrs
Average Depth at Peak Storage= 0.51'
Bank-Full Depth= 1.00' Flow Area= 12.0 sf, Capacity= 53.08 cfs

2.00' x 1.00' deep channel, n= 0.030 Short grass
Side Slope Z-value= 10.0 '/' Top Width= 22.00'
Length= 1,300.0' Slope= 0.0180 '/'
Inlet Invert= 100.00', Outlet Invert= 76.60'

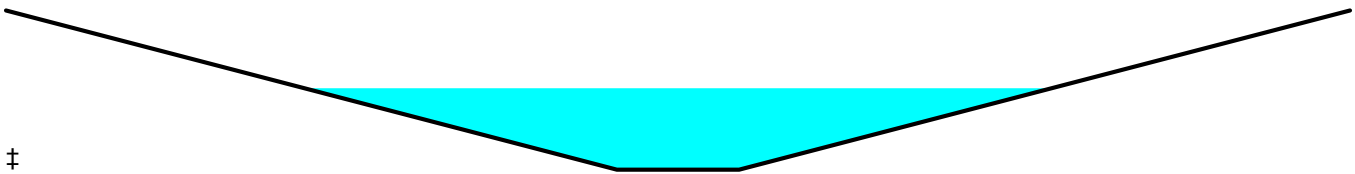

Reach CH: EXISTING DRAINAGE CHANNEL

Hydrograph

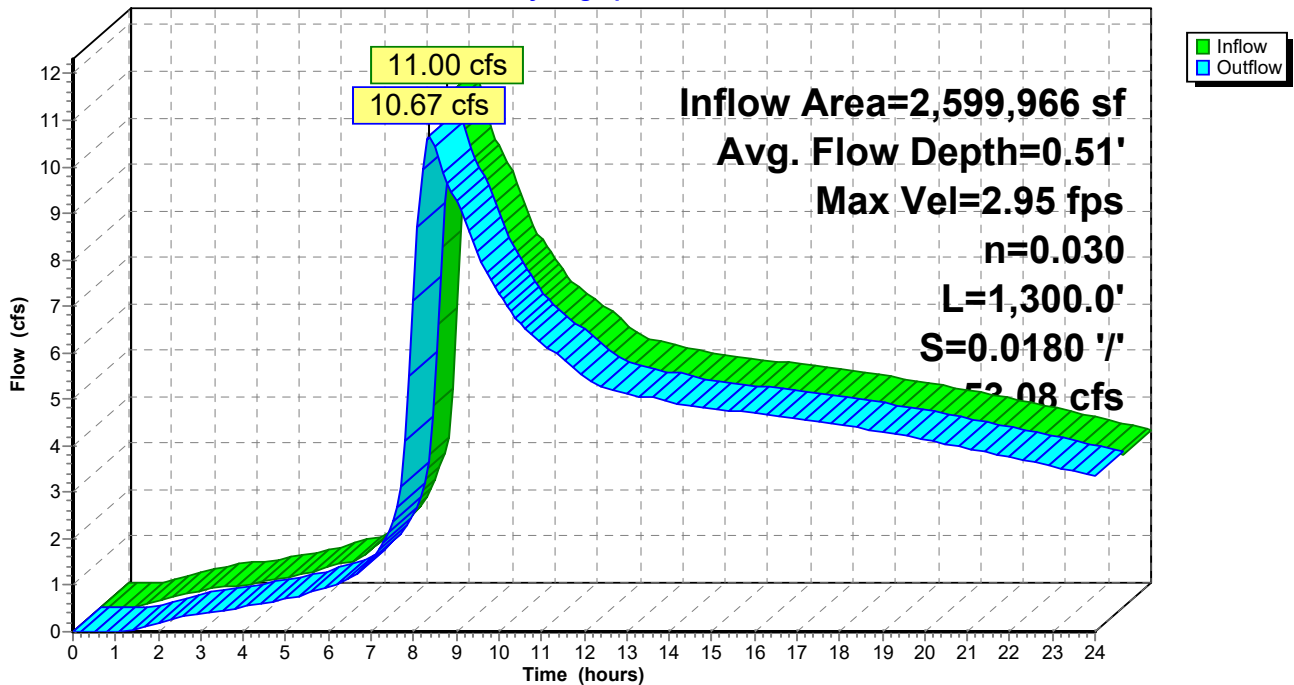

Exhibit H: Geotechnical Report



Real-World Geotechnical Solutions
Investigation • Design • Construction Support

April 2, 2021
Project No. 21-5743

Scott Newcombe
Venture Properties
4230 SW Galewood Street Suite 100
Lake Oswego, Oregon 97035
Email: scott@ventureprop.com

SUBJECT: GEOTECHNICAL ENGINEERING REPORT
CHANEY FROG POND PROPERTY
27227 SW STAFFORD ROAD
WILSONVILLE, OREGON

This report presents the results of a geotechnical engineering study conducted by GeoPacific Engineering, Inc. (GeoPacific) for the above-referenced project. The purpose of our investigation was to evaluate subsurface conditions at the site and to provide geotechnical recommendations for site development. This geotechnical study was performed in general accordance with GeoPacific Proposal No. P-7650, dated February 18, 2021 and your subsequent authorization of our proposal and *General Conditions for Geotechnical Services*.

SITE DESCRIPTION AND PROPOSED DEVELOPMENT

The subject site is located on the west side of SW Stafford Road in the City of Wilsonville, Clackamas County, Oregon (Figures 1 & 2). The property is composed of two tax lots that total approximately 8.3 acres in size. Topography is generally flat to very gently sloping to the northeast and southwest. The site is currently occupied by one home and barn and vegetation consists primarily of short grasses, landscaping, and sparse trees.

It is our understanding that the proposed development will consist of a 30 lot subdivision for single family homes, new streets, and associated underground utilities. A grading plan has not been provided for our review; however, we anticipate maximum cuts and fills will be on the order of about 10 feet.

REGIONAL AND LOCAL GEOLOGIC SETTING

Regionally, the subject site lies within the Willamette Valley/Puget Sound lowland, a broad structural depression situated between the Coast Range on the west and the Cascade Range on the east. A series of discontinuous faults subdivide the Willamette Valley into a mosaic of fault-

bounded, structural blocks (Yeats et al., 1996). Uplifted structural blocks form bedrock highlands, while down-warped structural blocks form sedimentary basins.

The site is underlain by the Quaternary age (last 1.6 million years) Willamette Formation, a catastrophic flood deposit associated with repeated glacial outburst flooding of the Willamette Valley (Gannett and Caldwell, 1998). The last of these outburst floods occurred about 10,000 years ago. These deposits typically consist of fluvial and lacustrine horizontally layered, micaceous, silt to coarse sand forming poorly-defined to distinct beds less than 3 feet thick.

The Willamette Formation is underlain by the Miocene age (about 14.5 to 16.5 million years ago) Columbia River Basalt Formation, a thick sequence of lava flows that form the crystalline bedrock of Tualatin Valley (Yeats et al., 1996; Gannett and Caldwell, 1998). These basalts are dense, finely crystalline rock that is commonly fractured along blocky and columnar vertical joints. Individual basalt flow units typically range from 25 to 125 feet thick and interflow zones are typically vesicular, scoriaceous, and brecciated, and sometimes include sedimentary rocks. Typically, the upper portion of the basalt is deeply weathered and decomposed to a residual soil consisting of red-brown, clayey silt.

REGIONAL SEISMIC SETTING

At least three potential source zones capable of generating damaging earthquakes are thought to exist in the region. These include the Portland Hills Fault Zone, the Gales Creek-Newberg-Mt. Angel Structural Zone, and the Cascadia Subduction Zone, as discussed below.

Portland Hills Fault Zone

The Portland Hills Fault Zone is a series of NW-trending faults that include the central Portland Hills Fault, the western Oatfield Fault, and the eastern East Bank Fault. These faults occur in a northwest-trending zone that varies in width between 3.5 and 5.0 miles. The combined three faults vertically displace the Columbia River Basalt by 1,130 feet and appear to control thickness changes in late Pleistocene (approx. 780,000 years) sediment (Madin, 1990). The Portland Hills Fault occurs along the Willamette River at the base of the Portland Hills and is approximately 9.5 miles northeast of the site. The East Bank Fault occurs along the eastern margin of the Willamette River and is located approximately 14.3 miles northeast of the site. The Oatfield Fault occurs along the western side of the Portland Hills and is approximately 8.4 miles northeast of the site. The accuracy of the fault mapping is stated to be within 500 meters (Wong, et al., 2000). No historical seismicity is correlated with the mapped portion of the Portland Hills Fault Zone, but in 1991 a M3.5 earthquake occurred on a NW-trending shear plane located 1.3 miles east of the fault (Yelin, 1992). Although there is no definitive evidence of recent activity, the Portland Hills Fault Zone is assumed to be potentially active (Geomatrix Consultants, 1995).

Gales Creek-Newberg-Mt. Angel Structural Zone

The Gales Creek-Newberg-Mt. Angel Structural Zone is a 50-mile-long zone of discontinuous, NW-trending faults that lies approximately 10.6 miles southwest of the subject site. These faults are recognized in the subsurface by vertical separation of the Columbia River Basalt and offset seismic reflectors in the overlying basin sediment (Yeats et al., 1996; Werner et al., 1992). A geologic reconnaissance and photogeologic analysis study conducted for the Scoggins Dam site in the Tualatin Basin revealed no evidence of deformed geomorphic surfaces along the structural zone (Unruh et al., 1994). No seismicity has been recorded on the Gales Creek Fault or Newberg Fault; however, these faults are considered to be potentially active because they may connect with the

seismically active Mount Angel Fault and the rupture plane of the 1993 M5.6 Scotts Mills earthquake (Werner et al. 1992; Geomatrix Consultants, 1995).

Cascadia Subduction Zone

The Cascadia Subduction Zone is a 680-mile-long zone of active tectonic convergence where oceanic crust of the Juan de Fuca Plate is subducting beneath the North American continent at a rate of 4 cm per year (Goldfinger et al., 1996). A growing body of geologic evidence suggests that prehistoric subduction zone earthquakes have occurred (Atwater, 1992; Carver, 1992; Peterson et al., 1993; Geomatrix Consultants, 1995). This evidence includes: (1) buried tidal marshes recording episodic, sudden subsidence along the coast of northern California, Oregon, and Washington, (2) burial of subsided tidal marshes by tsunami wave deposits, (3) paleoliquefaction features, and (4) geodetic uplift patterns on the Oregon coast. Radiocarbon dates on buried tidal marshes indicate a recurrence interval for major subduction zone earthquakes of 250 to 650 years with the last event occurring 300 years ago (Atwater, 1992; Carver, 1992; Peterson et al., 1993; Geomatrix Consultants, 1995). The inferred seismogenic portion of the plate interface lies approximately 50 miles west of the Portland Basin at depths of between 20 and 40 kilometers below the surface.

FIELD EXPLORATION

The site-specific exploration for this study was conducted on March 4, 2021. Seven exploratory borings (designated B-1 through B-7) were drilled to depths of 11.5 to 21.5 feet at the approximate locations presented on Figure 2. It should be noted that exploration locations were determined in the field by pacing or taping distances from apparent property corners and other site features shown on the plans provided. As such, the locations of the explorations should be considered approximate.

The boreholes were drilled using a trailer-mounted drill rig and solid stem auger methods. At each boring location, SPT (Standard Penetration Test) sampling was performed in general accordance with ASTM D1586 using a 2-inch outside diameter split-spoon sampler and a 140-pound hammer equipped with a rope and cathead mechanism. During the test, a sample is obtained by driving the sampler 18 inches into the soil with the hammer free-falling 30 inches. The number of blows for each 6 inches of penetration is recorded. The Standard Penetration Resistance ("N-value") of the soil is calculated as the number of blows required for the final 12 inches of penetration. If 50 or more blows are recorded within a single 6-inch interval, the test is terminated, and the blow count is recorded as 50 blows for the number of inches driven. This resistance, or N-value, provides a measure of the relative density of granular soils and the relative consistency of cohesive soils. At the completion of the borings, the holes were backfilled with bentonite.

Explorations were conducted under the full-time observation of a GeoPacific Engineering Geologist. Soil samples obtained from the boring were classified in the field and representative portions were placed in relatively air-tight plastic bags. These soil samples were then returned to the laboratory for further examination and laboratory testing. Pertinent information including soil sample depths, stratigraphy, soil engineering characteristics, and groundwater occurrence was recorded. Soils were classified in general accordance with the Unified Soil Classification System (USCS).

Summary borehole logs are attached. The stratigraphic contacts shown on the individual borehole logs represent the approximate boundaries between soil types. The actual transitions may be more gradual. The soil and groundwater conditions depicted are only for the specific dates and locations reported, and therefore, are not necessarily representative of other locations and times.

Undocumented Fill: Undocumented fill was not encountered in our explorations. It is likely that areas of undocumented fill may exist in the vicinity of the existing structures, driveway, and road rights-of-way.

Topsoil Horizon: The ground surface in borings B-1 through B-7 was directly underlain by a moderately organic topsoil horizon. The brown topsoil horizon consisted of silt (OL-ML), was soft, and contained fine roots. The topsoil horizon typically extended to a depth of 8 to 14 inches in explorations.

Willamette Formation: Underlying the topsoil horizon in borings B-1 through B-7 were catastrophic flood deposits belonging to the Willamette Formation. These soils generally consisted of medium stiff to stiff, micaceous, light brown silt (ML) with trace clay and silt with trace sand that exhibited subtle to strong orange and gray mottling. Soils belonging to the Willamette Formation extended to depth of 7 to 18 feet in borings B-1, B-2, B-6, and B-7 and beyond the maximum depth of exploration in borings B-3 through B-5 (11.5 feet).

Residual Soil: In borings B-1, B-2, B-6, and B-7, the Willamette Formation soils were underlain by residual resulting from in-place weathering of the underlying Columbia River Basalt Formation. The residual soil generally consisted of reddish brown silty CLAY (CL) to clayey SILT (ML) that had a stiff to very stiff consistency. The residual soil extended beyond the maximum depth of exploration in borings B-1, B-2, B-6, and B-7 (16.5 to 21.5 feet).

Soil Moisture and Groundwater

Soils encountered in explorations were damp to wet. Perched groundwater seepage was encountered in borings B-1 through B-7 and water levels rose to depths of 0.5 to 7.1 feet at the conclusion of drilling. These water levels reflect perched groundwater conditions - not static groundwater. According to our review of nearby Water Well logs, static groundwater is present at depths of approximately 55 to 90 feet below the ground surface (Oregon Water Resources Department, 2021). Experience has shown that temporary perched storm-related groundwater conditions often occur within the surface soils over fine-grained native deposits such as those beneath the site, particularly during the wet season. It is anticipated that groundwater conditions will vary depending on the season, local subsurface conditions, changes in site utilization, and other factors.

INFILTRATION TESTING

Soil infiltration testing was performed using the open-hole infiltration method in borings B-1 through B-5. Soil in the borings was pre-saturated for a period of over 1 hour. The water level was measured to the nearest tenth of an inch every fifteen minutes to half hour with reference to the ground surface. Table 1 presents the results of our falling head infiltration tests.

Table 1. Summary of Infiltration Test Results

Boring	Depth (feet)	Soil Type	Ultimate Infiltration Rate (in/hr)	Hydraulic Head Range (inches)
B-1	6	Silt (ML)	0	37-38
B-2	6	Clayey Silt (ML)	0	69-70
B-3	6	Silt (ML)	0	50-51
B-4	7	Silt (ML)	0	55-56
B-5	7	Silt (ML)	0	55-56

Exploratory borings encountered perched groundwater seepage that rose to depths of 0.5 to 7.1 feet at the conclusion of drilling. Due to the presence of the perched groundwater and fine grained soil conditions, it is our opinion that the site is not suitable for infiltration.

CONCLUSIONS AND RECOMMENDATIONS

Our investigation indicates that the proposed development is geotechnically feasible, provided that the recommendations of this report are incorporated into the design and construction phases of the project. The primary geotechnical constraints to development include low permeability soils and the presence of shallow, perched groundwater conditions that could make utility trenching difficult, especially in the winter months.

Site Preparation

Areas of proposed buildings, streets, and areas to receive fill should be cleared of vegetation and any organic and inorganic debris. Existing drain tiles and buried structures such as septic tanks, should be demolished and any cavities structurally backfilled. Areas of undocumented fill should be completely removed to native soils. Undocumented fill was not encountered in our explorations; however, areas of fill may be present in the vicinity of the existing structures and driveways. Inorganic debris should be removed from the site.

Organic-rich topsoil should then be stripped from native soil areas of the site. The estimated depth range necessary for removal of topsoil in cut and fill areas is approximately 6 to 9 inches, respectively. The final depth of soil removal will be determined on the basis of a site inspection after the stripping/excavation has been performed. Stripped topsoil should preferably be removed from the site due to the high density of the proposed development. Any remaining topsoil should be stockpiled only in designated areas and stripping operations should be observed and documented by the geotechnical engineer or his representative.

Once topsoil stripping and removal of organic and inorganic debris are approved in a particular area, the area must be ripped or tilled to a depth of 12 inches, moisture conditioned, root-picked, and compacted in-place prior to the placement of engineered fill or crushed aggregate base for pavement. Exposed subgrade soils should be evaluated by the geotechnical engineer. For large areas, this evaluation is normally performed by proof-rolling the exposed subgrade with a fully loaded scraper or dump truck. For smaller areas where access is restricted, the subgrade should be evaluated by probing the soil with a steel probe. Soft/loose soils identified during subgrade

preparation should be compacted to a firm and unyielding condition, over-excavated and replaced with engineered fill (as described below) or stabilized with rock prior to placement of engineered fill. The depth of overexcavation, if required, should be evaluated by the geotechnical engineer at the time of construction.

Engineered Fill

In general, we anticipate that soils from planned cuts and utility trench excavations will be suitable for use as engineered fill provided they are adequately moisture conditioned prior to compacting. All grading for the proposed construction should be performed as engineered grading in accordance with the applicable building code at time of construction with the exceptions and additions noted herein. Proper test frequency and earthwork documentation usually requires daily observation and testing during stripping, rough grading, and placement of engineered fill. Imported fill material must be approved by the geotechnical engineer prior to being imported to the site. Oversize material greater than 6 inches in size should not be used within 3 feet of foundation footings, and material greater than 12 inches in diameter should not be used in engineered fill.

Engineered fill should be compacted in horizontal lifts not exceeding 8 inches using standard compaction equipment. We recommend that engineered fill be compacted to at least 90% of the maximum dry density determined by ASTM D1557 (Modified Proctor) or equivalent. Field density testing should conform to ASTM D2922 and D3017, or D1556. All engineered fill should be observed and tested by the project geotechnical engineer or his representative. Typically, one density test is performed for at least every 2 vertical feet of fill placed or every 500 yd³, whichever requires more testing. Because testing is performed on an on-call basis, we recommend that the earthwork contractor be held contractually responsible for test scheduling and frequency.

Site earthwork will be impacted by soil moisture and shallow groundwater conditions. Earthwork in wet weather would likely require extensive use of cement or lime treatment, or other special measures, at considerable additional cost compared to earthwork performed under dry-weather conditions.

Excavating Conditions and Utility Trenches

Subsurface exploration indicates that, in general, utility trenches can be excavated using conventional heavy equipment such as dozers and trackhoes. Shallow, perched groundwater conditions could cause sidewall caving in excavations. These conditions could make utility trenching difficult, especially in the winter months, and adequate shoring should be maintained.

All temporary cuts in excess of 4 feet in height should be sloped in accordance with U.S. Occupational Safety and Health Administration (OSHA) regulations (29 CFR Part 1926) or be shored. The existing, near surface, native soils classify as Type B Soil and shallow, temporary excavation side slope inclinations as steep as 1H:1V may be assumed for planning purposes. This cut slope inclination is applicable to excavations above the water table only. Maintenance of safe working conditions, including temporary excavation stability, is the responsibility of the contractor. Actual slope inclinations at the time of construction should be determined based on safety requirements and actual soil and groundwater conditions.

Saturated soils and groundwater may be encountered in utility trenches, particularly during the wet season. We anticipate that dewatering systems consisting of ditches, sumps and pumps would be adequate for control of perched groundwater. Regardless of the dewatering system used, it should be installed and operated such that in-place soils are prevented from being removed along with the groundwater.

Vibrations created by traffic and construction equipment may cause some caving and raveling of excavation walls. In such an event, lateral support for the excavation walls should be provided by the contractor to prevent loss of ground support and possible distress to existing or previously constructed structural improvements.

PVC pipe should be installed in accordance with the procedures specified in ASTM D2321. We recommend that the upper 4 feet of trench backfill be compacted to at least 95% of the maximum dry density obtained by Modified Proctor ASTM D1557 or equivalent. Trench backfill below 4 feet should be compacted to at least 90% of the maximum dry density obtained by Modified Proctor ASTM D1557 or equivalent. Initial backfill lift thickness for a ¾"-0 crushed aggregate base may need to be as great as 4 feet to reduce the risk of flattening underlying flexible pipe. Subsequent lift thickness should not exceed 1 foot. If imported granular fill material is used, then the lifts for large vibrating plate-compaction equipment (e.g. hoe compactor attachments) may be up to 2 feet, provided that proper compaction is being achieved and each lift is tested. Use of large vibrating compaction equipment should be carefully monitored near existing structures and improvements due to the potential for vibration-induced damage.

Adequate density testing should be performed during construction to verify that the recommended relative compaction is achieved. Typically, one density test is taken for every 4 vertical feet of backfill on each 200-lineal-foot section of trench.

Erosion Control Considerations

During our field exploration program, we did not observe soil types that would be considered highly susceptible to erosion. In our opinion, the primary concern regarding erosion potential will occur during construction, in areas that have been stripped of vegetation. Erosion at the site during construction can be minimized by implementing the project erosion control plan, which should include judicious use of straw wattles and silt fences. If used, these erosion control devices should be in place and remain in place throughout site preparation and construction.

Erosion and sedimentation of exposed soils can also be minimized by quickly re-vegetating exposed areas of soil, and by staging construction such that large areas of the project site are not denuded and exposed at the same time. Areas of exposed soil requiring immediate and/or temporary protection against exposure should be covered with either mulch or erosion control netting/blankets. Areas of exposed soil requiring permanent stabilization should be seeded with an approved grass seed mixture, or hydroseeded with an approved seed-mulch-fertilizer mixture.

Wet Weather Earthwork

Soils underlying the site are likely to be moisture sensitive and may be difficult to handle or traverse with construction equipment during periods of wet weather. Earthwork is typically most economical when performed under dry weather conditions. Earthwork performed during the wet-weather season will probably require expensive measures such as cement treatment or imported granular material to compact fill to the recommended engineering specifications. If earthwork is to be performed or fill is to be placed in wet weather or under wet conditions when soil moisture content is difficult to control, the following recommendations should be incorporated into the contract specifications.

- Earthwork should be performed in small areas to minimize exposure to wet weather. Excavation or the removal of unsuitable soils should be followed promptly by the placement and compaction of clean engineered fill. The size and type of construction equipment used

may have to be limited to prevent soil disturbance. Under some circumstances, it may be necessary to excavate soils with a backhoe to minimize subgrade disturbance caused by equipment traffic;

- The ground surface within the construction area should be graded to promote run-off of surface water and to prevent the ponding of water;
- Material used as engineered fill should consist of clean, granular soil containing less than 5 percent fines. The fines should be non-plastic. Alternatively, cement treatment of on-site soils may be performed to facilitate wet weather placement;
- The ground surface within the construction area should be sealed by a smooth drum vibratory roller, or equivalent, and under no circumstances should be left uncompacted and exposed to moisture. Soils which become too wet for compaction should be removed and replaced with clean granular materials;
- Excavation and placement of fill should be observed by the geotechnical engineer to verify that all unsuitable materials are removed and suitable compaction and site drainage is achieved; and
- Straw wattles and/or geotextile silt fences should be strategically located to control erosion.

If cement or lime treatment is used to facilitate wet weather construction, GeoPacific should be contacted to provide additional recommendations and field monitoring.

Spread Foundations

The proposed residential structures may likely be supported on shallow foundations bearing on competent undisturbed, native low expansivity soils and/or engineered fill, appropriately designed and constructed as recommended in this report. Foundation design, construction, and setback requirements should conform to the applicable building code at the time of construction. For maximization of bearing strength and protection against frost heave, spread footings should be embedded at a minimum depth of 12 inches below exterior grade. The recommended minimum widths for continuous footings supporting wood-framed walls without masonry are 12 inches for single-story, 15 inches for two-story, and 18 inches for three-story structures. Minimum foundation reinforcement should consist of a No. 4 bar at the top of the stem walls, and a No. 4 bar at the bottom of the footings. Concrete slab-on-grade reinforcement should consist of No. 4 bars placed on 24-inch centers in a grid pattern.

The anticipated allowable soil bearing pressure is 1,500 lbs/ft² for footings bearing on competent, native soil and/or engineered fill. A maximum chimney and column load of 40 kips is recommended for the site. The recommended maximum allowable bearing pressure may be increased by 1/3 for short-term transient conditions such as wind and seismic loading. For heavier loads, the geotechnical engineer should be consulted. The coefficient of friction between on-site soil and poured-in-place concrete may be taken as 0.42, which includes no factor of safety. The maximum anticipated total and differential footing movements (generally from soil expansion and/or settlement) are 1 inch and ¾ inch over a span of 20 feet, respectively. We anticipate that the majority of the estimated settlement will occur during construction, as loads are applied. Excavations near structural footings should not extend within a 1H:1V plane projected downward from the bottom edge of footings.

Footing excavations should penetrate through topsoil and any loose soil to competent subgrade that is suitable for bearing support. All footing excavations should be trimmed neat, and all loose or softened soil should be removed from the excavation bottom prior to placing reinforcing steel

bars. Due to the moisture sensitivity of on-site native soils, foundations constructed during the wet weather season may require overexcavation of footings and backfill with compacted, crushed aggregate.

Our recommendations are for house construction incorporating raised wood floors and conventional spread footing foundations. If living space of the structures will incorporate basements, a geotechnical engineer should be consulted to make additional recommendations for retaining walls, water-proofing, underslab drainage and wall subdrains. After site development, a Final Soil Engineer's Report should either confirm or modify the above recommendations.

Concrete Slabs-on-Grade

Preparation of areas beneath concrete slab-on-grade floors should be performed as recommended in the *Site Preparation and Undocumented Fill Removal* section. Care should be taken during excavation for foundations and floor slabs, to avoid disturbing subgrade soils. If subgrade soils have been adversely impacted by wet weather or otherwise disturbed, the surficial soils should be scarified to a minimum depth of 8 inches, moisture conditioned to within about 3 percent of optimum moisture content, and compacted to engineered fill specifications. Alternatively, disturbed soils may be removed and the removal zone backfilled with additional crushed rock.

For evaluation of the concrete slab-on-grade floors using the beam on elastic foundation method, a modulus of subgrade reaction of 150 kcf (87 pci) should be assumed for the medium stiff native silt soils anticipated at subgrade depth. This value assumes the concrete slab system is designed and constructed as recommended herein, with a minimum thickness of crushed rock of 8 inches beneath the slab.

Interior slab-on-grade floors should be provided with an adequate moisture break. The capillary break material should consist of ODOT open graded aggregate per ODOT Standard Specifications 02630-2. The minimum recommended thickness of capillary break materials on re-compacted soil subgrade is 8 inches. The total thickness of crushed aggregate will be dependent on the subgrade conditions at the time of construction, and should be verified visually by proof-rolling. Under-slab aggregate should be compacted to at least 90% of its maximum dry density as determined by ASTM D1557 or equivalent.

In areas where moisture will be detrimental to floor coverings or equipment inside the proposed structure, appropriate vapor barrier and damp-proofing measures should be implemented. A commonly applied vapor barrier system consists of a 10-mil polyethylene vapor barrier placed directly over the capillary break material. Other damp/vapor barrier systems may also be feasible. Appropriate design professionals should be consulted regarding vapor barrier and damp proofing systems, ventilation, building material selection and mold prevention issues, which are outside GeoPacific's area of expertise.

Permanent Below-Grade Walls

Lateral earth pressures against below-grade retaining walls will depend upon the inclination of any adjacent slopes, type of backfill, degree of wall restraint, method of backfill placement, degree of backfill compaction, drainage provisions, and magnitude and location of any adjacent surcharge loads. At-rest soil pressure is exerted on a retaining wall when it is restrained against rotation. In contrast, active soil pressure will be exerted on a wall if its top is allowed to rotate or yield a distance of roughly 0.001 times its height or greater.

If the subject retaining walls will be free to rotate at the top, they should be designed for an active earth pressure equivalent to that generated by a fluid weighing 35 pcf for level backfill against the wall. For restrained wall, an at-rest equivalent fluid pressure of 55 pcf should be used in design, again assuming level backfill against the wall. These values assume that drainage provisions are incorporated, free draining gravel backfill is used, and hydrostatic pressures are not allowed to develop against the wall.

During a seismic event, lateral earth pressures acting on below-grade structural walls will increase by an incremental amount that corresponds to the earthquake loading. Based on the Mononobe-Okabe equation and peak horizontal accelerations appropriate for the site location, seismic loading should be modeled using the active or at-rest earth pressures recommended above, plus an incremental rectangular-shaped seismic load of magnitude $6.5H$, where H is the total height of the wall.

We assume relatively level ground surface below the base of the walls. As such, we recommend passive earth pressure of 320 pcf for use in design, assuming wall footings are cast against competent native soils or engineered fill. If the ground surface slopes down and away from the base of any of the walls, a lower passive earth pressure should be used and GeoPacific should be contacted for additional recommendations.

A coefficient of friction of 0.42 may be assumed along the interface between the base of the wall footing and subgrade soils. The recommended coefficient of friction and passive earth pressure values do not include a safety factor, and an appropriate safety factor should be included in design. The upper 12 inches of soil should be neglected in passive pressure computations unless it is protected by pavement or slabs on grade.

The above recommendations for lateral earth pressures assume that the backfill behind the subsurface walls will consist of properly compacted structural fill, and no adjacent surcharge loading. If the walls will be subjected to the influence of surcharge loading within a horizontal distance equal to or less than the height of the wall, the walls should be designed for the additional horizontal pressure. For uniform surcharge pressures, a uniformly distributed lateral pressure of 0.3 times the surcharge pressure should be added. Traffic surcharges may be estimated using an additional vertical load of 250 psf (2 feet of additional fill), in accordance with local practice.

The recommended equivalent fluid densities assume a free-draining condition behind the walls so that hydrostatic pressures do not build-up. This can be accomplished by placing a 12 to 18-inch wide zone of sand and gravel containing less than 5 percent passing the No. 200 sieve against the walls. A 3-inch minimum diameter perforated, plastic drain pipe should be installed at the base of the walls and connected to a suitable discharge point to remove water in this zone of sand and gravel. The drain pipe should be wrapped in filter fabric (Mirafi 140N or other as approved by the geotechnical engineer) to minimize clogging.

Wall drains are recommended to prevent detrimental effects of surface water runoff on foundations – not to dewater groundwater. Drains should not be expected to eliminate all potential sources of water entering a basement or beneath a slab-on-grade. An adequate grade to a low point outlet drain in the crawlspace is required by code. Underslab drains are sometimes added beneath the slab when placed over soils of low permeability and shallow, perched groundwater.

Water collected from the wall drains should be directed into the local storm drain system or other suitable outlet. A minimum 0.5 percent fall should be maintained throughout the drain and non-perforated pipe outlet. Down spouts and roof drains should not be connected to the wall drains in order to reduce the potential for clogging. The drains should include clean-outs to allow periodic

maintenance and inspection. Grades around the proposed structure should be sloped such that surface water drains away from the building.

GeoPacific should be contacted during construction to verify subgrade strength in wall keyway excavations, to verify that backslope soils are in accordance with our assumptions, and to take density tests on the wall backfill materials.

Structures should be located a horizontal distance of at least 1.5H away from the back of the retaining wall, where H is the total height of the wall. GeoPacific should be contacted for additional foundation recommendations where structures are located closer than 1.5H to the top of any wall.

Pavement Design

For design purposes, we used an estimated resilient modulus of 9,000 for compacted native soil. Table 2 presents our recommended minimum pavement section for dry weather construction.

Table 2. Recommended Minimum Dry-Weather Pavement Section

Material Layer	Light-duty Public Streets	Compaction Standard
Asphaltic Concrete (AC)	3 in.	92% of Rice Density AASHTO T-209
Crushed Aggregate Base ¾"-0 (leveling course)	2 in.	95% of Modified Proctor AASHTO T-180
Crushed Aggregate Base 1½"-0	8 in.	95% of Modified Proctor AASHTO T-180
Subgrade	12 in.	95% of Standard Proctor AASHTO T-99 or equivalent

Any pockets of organic debris or loose fill encountered during ripping or tilling should be removed and replaced with engineered fill (see *Site Preparation* Section). In order to verify subgrade strength, we recommend proof-rolling directly on subgrade with a loaded dump truck during dry weather and on top of base course in wet weather. Soft areas that pump, rut, or weave should be stabilized prior to paving. If pavement areas are to be constructed during wet weather, the subgrade and construction plan should be reviewed by the project geotechnical engineer at the time of construction so that condition specific recommendations can be provided. The moisture sensitive subgrade soils make the site a difficult wet weather construction project.

During placement of pavement section materials, density testing should be performed to verify compliance with project specifications. Generally, one subgrade, one base course, and one asphalt compaction test is performed for every 100 to 200 linear feet of paving.

Seismic Design

The Oregon Department of Geology and Mineral Industries (DOGAMI), Oregon HazVu: 2021 Statewide GeoHazards Viewer indicates that the site is in an area where severe ground shaking is anticipated during an earthquake (DOGAMI HazVu, 2021). Structures should be designed to resist earthquake loading in accordance with the methodology described in the 2018 International Building Code (IBC) with applicable Oregon Structural Specialty Code (OSSC) revisions (current 2019). We recommend Site Class D be used for design as defined in ASCE 7, Chapter 20, Table

20.3-1. Design values determined for the site using the ATC (Applied Technology Council) *ASCE7-16 Hazards by Location online Tool* website are summarized in Table 3.

Table 3. Recommended Earthquake Ground Motion Parameters (ATC 2021)

Parameter	Value
Location (Lat, Long), degrees	45.324, -122.745
Mapped Spectral Acceleration Values (MCE):	
Peak Ground Acceleration PGA_M	0.458 g
Short Period, S_s	0.821 g
1.0 Sec Period, S_1	0.380 g
Soil Factors for Site Class D:	
F_a	1.172
F_v	*1.920
$SD_s = 2/3 \times F_a \times S_s$	0.641 g
$SD_1 = 2/3 \times F_v \times S_1$	*0.487 g
Seismic Design Category	D

* The F_v value reported in the above table is a straight-line interpolation of mapped spectral response acceleration at 1-second period, S_1 per Table 1613.2.3(2) of OSSC 2019 with the assumption that Exception 2 of ASCE 7-16 Chapter 11.4.8 is met. SD_1 is based on the F_v value. The structural engineer should evaluate exception 2 and determine whether or not the exception is met. If Exception 2 is not met, and the long-period site coefficient (F_v) is required for design, GeoPacific Engineering can be consulted to provide a site-specific procedure as per ASCE 7-16, Chapter 21.

Soil Liquefaction

Soil liquefaction is a phenomenon wherein saturated soil deposits temporarily lose strength and behave as a liquid in response to earthquake shaking. Soil liquefaction is generally limited to loose, granular soils located below the water table. The Oregon Department of Geology and Mineral Industries (DOGAMI), Oregon HazVu: 2021 Statewide GeoHazards Viewer indicates that the northern portion of the site is considered to have a low risk for soil liquefaction and the southern and eastern portions are considered to have a moderate liquefaction risk. Our explorations indicate that the near surface soils underlying the site are not susceptible to liquefaction.

Other Potential Seismic Impacts

Other potential seismic impacts include fault rupture potential. However, based on our review of available geologic literature, we are not aware of any mapped active (demonstrating movement in the last 10,000 years) faults on the site. During our field investigation, we did not observe any evidence of surface rupture or recent faulting. Therefore, we conclude that the potential for fault rupture on site is very low.

Footing and Roof Drains

Construction should include typical measures for controlling subsurface water beneath the homes, including positive crawlspace drainage to an adequate low-point drain exiting the foundation, visqueen covering the expose ground in the crawlspace, and crawlspace ventilation (foundation vents). The homebuyers should be informed and educated that some slow flowing water in the crawlspaces is considered normal and not necessarily detrimental to the home given these other design elements incorporated into its construction. Appropriate design professionals should be consulting regarding crawlspace ventilation, building material selection and mold prevention issues, which are outside GeoPacific's area of expertise.

Down spouts and roof drains should collect roof water in a system separate from the footing drains to reduce the potential for clogging. Roof drain water should be directed to an appropriate discharge point and storm system well away from structural foundations. Grades should be sloped downward and away from buildings to reduce the potential for ponded water near structures.

If the proposed structures will have a raised floor, and no concrete slab-on-grade floors in living spaces are used, perimeter footing drains would not be required based on soil conditions encountered at the site and experience with standard local construction practices. Where it is desired to reduce the potential for moist crawl spaces, footing drains may be installed. If concrete slab-on-grade floors are used, perimeter footing drains should be installed as recommended below.

Where necessary, perimeter footing drains should consist of 3 or 4-inch diameter, perforated plastic pipe embedded in a minimum of 1 ft³ per lineal foot of clean, free-draining drain rock. The drain pipe and surrounding drain rock should be wrapped in non-woven geotextile (Mirafi 140N, or approved equivalent) to minimize the potential for clogging and/or ground loss due to piping. A minimum 0.5 percent fall should be maintained throughout the drain and non-perforated pipe outlet. In our opinion, footing drains may outlet at the curb, or on the back sides of lots where sufficient fall is not available to allow drainage to meet the street.

UNCERTAINTIES AND LIMITATIONS

We have prepared this report for the owner and their consultants for use in design of this project only. This report should be provided in its entirety to prospective contractors for bidding and estimating purposes; however, the conclusions and interpretations presented in this report should not be construed as a warranty of the subsurface conditions. Experience has shown that soil and groundwater conditions can vary significantly over small distances. Inconsistent conditions can occur between explorations that may not be detected by a geotechnical study. If, during future site operations, subsurface conditions are encountered which vary appreciably from those described herein, GeoPacifc should be notified for review of the recommendations of this report, and revision of such if necessary.

Sufficient geotechnical monitoring, testing and consultation should be provided during construction to confirm that the conditions encountered are consistent with those indicated by explorations. The checklist attached to this report outlines recommended geotechnical observations and testing for the project. Recommendations for design changes will be provided should conditions revealed during construction differ from those anticipated, and to verify that the geotechnical aspects of construction comply with the contract plans and specifications.

Within the limitations of scope, schedule and budget, GeoPacifc attempted to execute these services in accordance with generally accepted professional principles and practices in the fields of geotechnical engineering and engineering geology at the time the report was prepared. No warranty, expressed or implied, is made. The scope of our work did not include environmental assessments or evaluations regarding the presence or absence of wetlands or hazardous or toxic substances in the soil, surface water, or groundwater at this site.

We appreciate this opportunity to be of service.

Sincerely,

GEO PACIFIC ENGINEERING, INC.



Beth K. Rapp, C.E.G.
Senior Engineering Geologist



Reviewed by: James D. Imbrie, G.E., C.E.G.
Principal Geotechnical Engineer

Attachments: References
Figure 1 – Vicinity Map
Figure 2 – Site Plan and Exploration Locations
Boring Logs (B-1 through B-7)

REFERENCES

- Applied Technology Council (ATC), 2021, Hazards by Location Online Tool, <https://hazards.atcouncil.org/#/seismic>
- Atwater, B.F., 1992, Geologic evidence for earthquakes during the past 2,000 years along the Copalis River, southern coastal Washington: *Journal of Geophysical Research*, v. 97, p. 1901-1919.
- Carver, G.A., 1992, Late Cenozoic tectonics of coastal northern California: American Association of Petroleum Geologists-SEPM Field Trip Guidebook, May, 1992.
- Gannett, M.W. and Caldwell, R.R., 1998, Geologic framework of the Willamette Lowland aquifer system, Oregon and Washington: U.S. Geological Survey Professional Paper 1424-A, 32 pages text, 8 plates.
- Geomatrix Consultants, 1995, Seismic Design Mapping, State of Oregon: unpublished report prepared for Oregon Department of Transportation, Personal Services Contract 11688, January 1995.
- Goldfinger, C., Kulm, L.D., Yeats, R.S., Appelgate, B, MacKay, M.E., and Cochrane, G.R., 1996, Active strike-slip faulting and folding of the Cascadia Subduction-Zone plate boundary and forearc in central and northern Oregon: in *Assessing earthquake hazards and reducing risk in the Pacific Northwest*, v. 1: U.S. Geological Survey Professional Paper 1560, P. 223-256.
- Madin, I.P., 1990, Earthquake hazard geology maps of the Portland metropolitan area, Oregon: Oregon Department of Geology and Mineral Industries Open-File Report 0-90-2, scale 1:24,000, 22 p.
- Oregon Department of Geology and Mineral Industries, 2021, Oregon HazVu: Statewide Geohazards Viewer (HazVu): <http://www.oregongeology.org/hazvu/>
- Oregon Water Resources Department, 2021, Well Report Query: https://apps.wrd.state.or.us/apps/gw/well_log/
- Peterson, C.D., Darioenzo, M.E., Burns, S.F., and Burris, W.K., 1993, Field trip guide to Cascadia paleoseismic evidence along the northern California coast: evidence of subduction zone seismicity in the central Cascadia margin: *Oregon Geology*, v. 55, p. 99-144.
- Unruh, J.R., Wong, I.G., Bott, J.D., Silva, W.J., and Lettis, W.R., 1994, Seismotectonic evaluation: Scoggins Dam, Tualatin Project, Northwest Oregon: unpublished report by William Lettis and Associates and Woodward Clyde Federal Services, Oakland, CA, for U. S. Bureau of Reclamation, Denver CO (in Geomatrix Consultants, 1995).
- Werner, K.S., Nabelek, J., Yeats, R.S., Malone, S., 1992, The Mount Angel fault: implications of seismic-reflection data and the Woodburn, Oregon, earthquake sequence of August, 1990: *Oregon Geology*, v. 54, p. 112-117.
- Wong, I. Silva, W., Bott, J., Wright, D., Thomas, P., Gregor, N., Li, S., Mabey, M., Sojourner, A., and Wang, Y., 2000, Earthquake Scenario and Probabilistic Ground Shaking Maps for the

Chaney Frog Pond Property
Project No. 21-5743

Portland, Oregon, Metropolitan Area; State of Oregon Department of Geology and Mineral Industries; Interpretative Map Series IMS-16.

Yeats, R.S., Graven, E.P., Werner, K.S., Goldfinger, C., and Popowski, T., 1996, Tectonics of the Willamette Valley, Oregon: in Assessing earthquake hazards and reducing risk in the Pacific Northwest, v. 1: U.S. Geological Survey Professional Paper 1560, P. 183-222, 5 plates, scale 1:100,000.

Yelin, T.S., 1992, An earthquake swarm in the north Portland Hills (Oregon): More speculations on the seismotectonics of the Portland Basin: Geological Society of America, Programs with Abstracts, v. 24, no. 5, p. 92.



14835 SW 72nd Avenue
 Portland, Oregon 97224
 Tel: (503) 598-8445 Fax: (503) 941-9281

VICINITY MAP

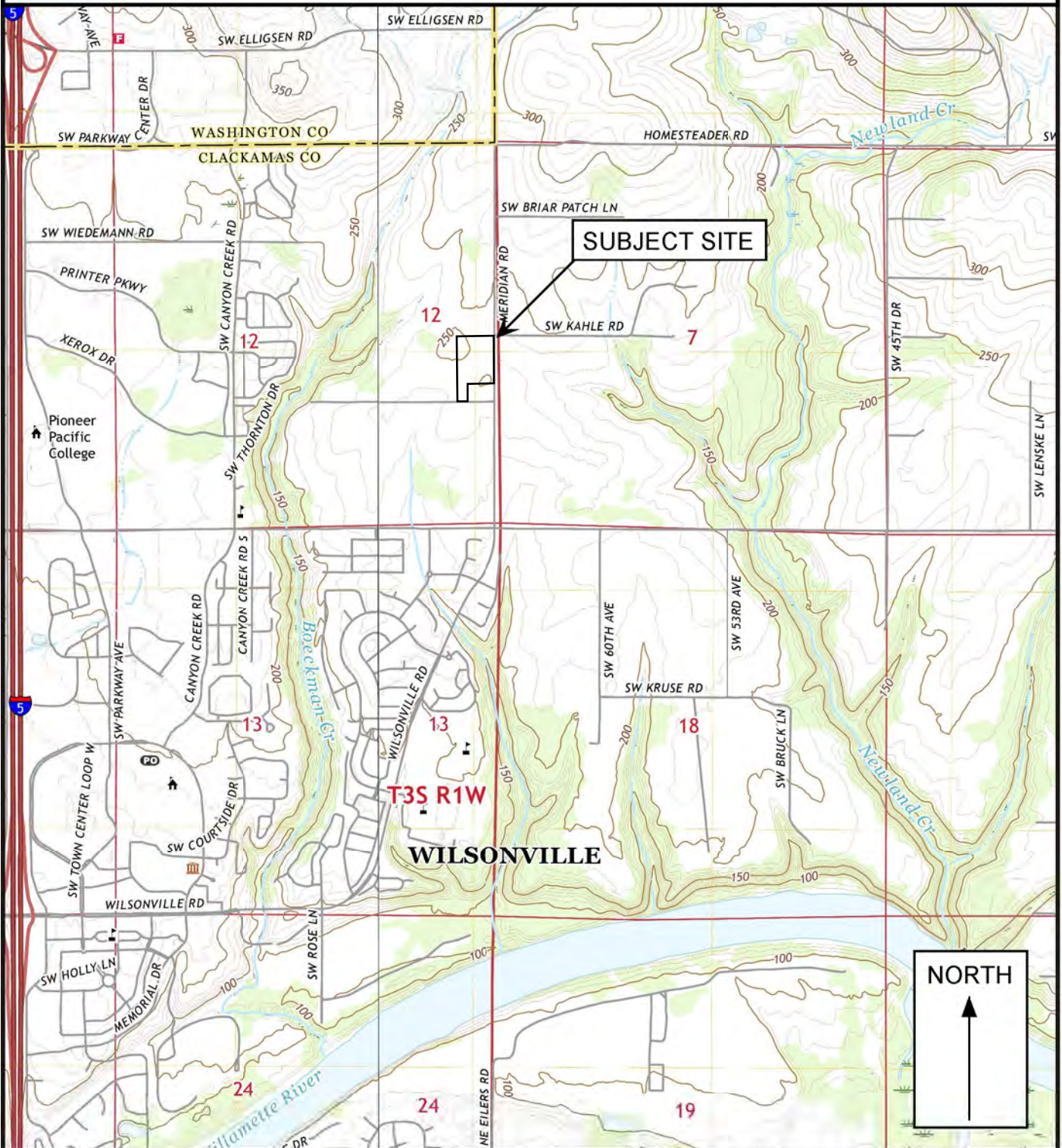

Legend Date: 4/2/2021
Drawn by: EKR

Approximate Scale 1 in = 2,000 feet

Base map: U.S. Geological Survey 7.5 minute Topographic Map Series, Canby, Oregon Quadrangle, and Sherwood, Oregon Quadrangle, 2020.

Project: Chaney Frog Pond Property Wilsonville, Oregon	Project No. 21-5743	FIGURE 1
---	---------------------	----------



14835 SW 72nd Avenue
 Portland, Oregon 97224
 Tel: (503) 598-8445 Fax: (503) 941-9281

SITE PLAN AND EXPLORATION LOCATIONS

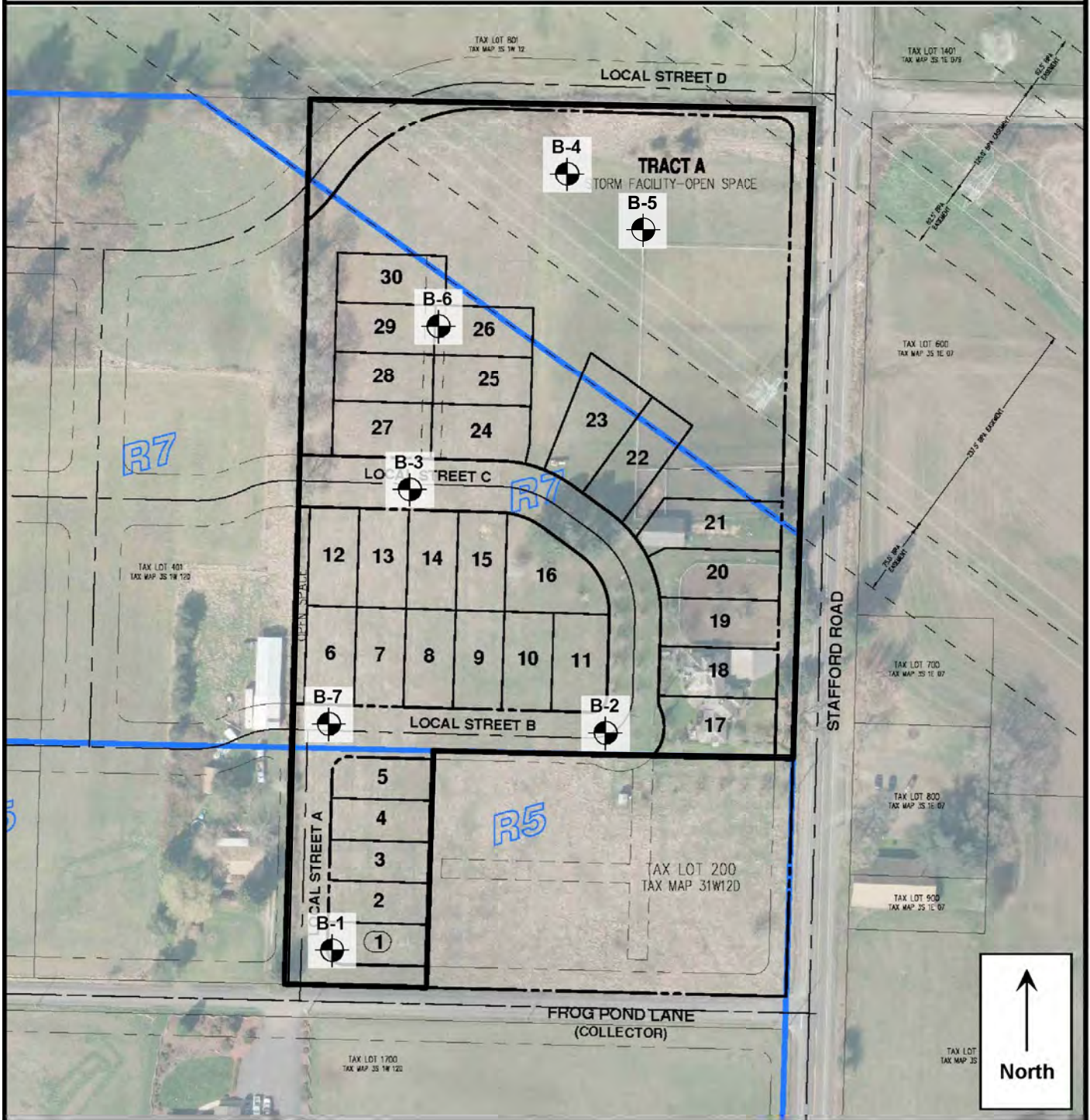

Legend

B-1  Boring Designation and Approximate Location

Date: 4/2/2021
 Drawn by: EKR

0 150'
 APPROXIMATE SCALE 1"=150'

Project: Chaney Frog Pond Property
 Wilsonville, Oregon

Project No. 21-5743

FIGURE 2



14835 SW 72nd Avenue
 Portland, Oregon 97224
 Tel: (503) 598-8445 Fax: (503) 941-9281

BORING LOG

Project: Chaney Frog Pond Property
 Willsonville, Oregon

Project No. 21-5743

Boring No. **B-1**

Depth (ft)	Sample Type	N-Value	Well Construction	Moisture Content (%)	Water Bearing Zone	Material Description
0 - 3		3				Soft, moderately organic SILT (OL-ML), brown, with roots, loose, moist (Topsoil Horizon)
3 - 14		14				Medium stiff to stiff, SILT (ML), trace sand, light brown to gray, micaceous, subtle to strong orange and gray mottling, trace black staining, sand is fine grained, moist to wet (Willamette Formation)
14 - 7		7				
7 - 4		4				
4 - 5		5				
5 - 15		5				Very stiff, silty CLAY to clayey SILT (CL-ML), light reddish brown, trace black staining, moist (Residual Soil)
15 - 20		5				
20 - 21.5		29				Boring Terminated at 21.5 feet. Groundwater Encountered at 7.1 Feet.

LEGEND



Bag Sample



Split-Spoon



Shelby Tube Sample



Static Water Table at Drilling



Static Water Table



Water Bearing Zone

Date Drilled: 3/4/2021

Logged By: B. Rapp

Surface Elevation:









14835 SW 72nd Avenue
 Portland, Oregon 97224
 Tel: (503) 598-8445 Fax: (503) 941-9281

BORING LOG

Project: Chaney Frog Pond Property
 Willsonville, Oregon

Project No. 21-5743

Boring No. **B-2**

Depth (ft)	Sample Type	N-Value	Well Construction	Moisture Content (%)	Water Bearing Zone	Material Description
0 - 5		5				Soft, moderately organic SILT (OL-ML), brown, with roots, loose, moist (Topsoil Horizon)
5 - 8		8				Medium stiff to stiff, clayey SILT (ML) to SILT, trace sand, light brown to gray, micaceous, subtle to strong orange and gray mottling, trace black staining, sand is fine grained, moist to wet (Willamette Formation)
8 - 10		8				
10 - 15		4				
15 - 20		6				Stiff to very stiff, silty CLAY to clayey SILT (CL-ML), light reddish brown, trace black staining, damp to moist (Residual Soil)
20 - 21.5		11				
21.5 - 25		22				Boring Terminated at 21.5 feet. Groundwater Encountered at 2.8 Feet.

LEGEND



100 to 1,000 g
Bag Sample



Split-Spoon



Shelby Tube Sample



Static Water Table at Drilling



10-20-99
Static Water Table



Water Bearing Zone

Date Drilled: 3/4/2021

Logged By: B. Rapp

Surface Elevation:



14835 SW 72nd Avenue
 Portland, Oregon 97224
 Tel: (503) 598-8445 Fax: (503) 941-9281

BORING LOG

Project: Chaney Frog Pond Property
 Willsonville, Oregon

Project No. 21-5743

Boring No. **B-3**

Depth (ft)	Sample Type	N-Value	Well Construction	Moisture Content (%)	Water Bearing Zone	Material Description
0 - 2		2				Soft, moderately organic SILT (OL-ML), brown, with roots, loose, moist (Topsoil Horizon)
2.2						
2.2 - 11.5		16				Medium stiff to stiff, SILT (ML), light brown to gray, micaceous, subtle to strong orange and gray mottling, trace black staining, moist to wet (Willamette Formation)
5 - 8		8				
8 - 10		4				
10 - 11.5		8				
11.5 - 25						Boring Terminated at 11.5 feet. Groundwater Encountered at 2.2 Feet.

LEGEND



Bag Sample



Split-Spoon



Shelby Tube Sample



Static Water Table at Drilling



Static Water Table



Water Bearing Zone

Date Drilled: 3/4/2021

Logged By: B. Rapp

Surface Elevation:



14835 SW 72nd Avenue
 Portland, Oregon 97224
 Tel: (503) 598-8445 Fax: (503) 941-9281

BORING LOG

Project: Chaney Frog Pond Property
 Willsonville, Oregon

Project No. 21-5743

Boring No. **B-4**

Depth (ft)	Sample Type	N-Value	Well Construction	Moisture Content (%)	Water Bearing Zone	Material Description
0 - 4		4				Soft, moderately organic SILT (OL-ML), brown, with roots, loose, moist (Topsoil Horizon)
4 - 19		19				Medium stiff to stiff, SILT (ML), light brown to gray, micaceous, subtle to strong orange and gray mottling, trace black staining, moist to wet (Willamette Formation)
19 - 9		9				
9 - 4		4				
4 - 7		7				
7 - 11.5						Boring Terminated at 11.5 feet. Groundwater Encountered at 2.0 Feet.

LEGEND



Bag Sample



Split-Spoon



Shelby Tube Sample



Static Water Table at Drilling



Static Water Table



Water Bearing Zone

Date Drilled: 3/4/2021

Logged By: B. Rapp

Surface Elevation:









14835 SW 72nd Avenue
 Portland, Oregon 97224
 Tel: (503) 598-8445 Fax: (503) 941-9281

BORING LOG

Project: Chaney Frog Pond Property
 Willsonville, Oregon

Project No. 21-5743

Boring No. **B-5**

Depth (ft)	Sample Type	N-Value	Well Construction	Moisture Content (%)	Water Bearing Zone	Material Description
0		1				Soft, moderately organic SILT (OL-ML), brown, with roots, loose, moist (Topsoil Horizon)
5		16				Medium stiff to stiff, SILT (ML), trace clay, light brown to gray, micaceous, subtle to strong orange and gray mottling, trace black staining, moist to wet (Willamette Formation)
10		10				
11.5		7				
15		5				Boring Terminated at 11.5 feet. Groundwater Encountered at 0.5 Feet.
20						
25						

LEGEND



100 to 1,000 g
Bag Sample



Split-Spoon



Shelby Tube Sample



Static Water Table at Drilling



Static Water Table



Water Bearing Zone

Date Drilled: 3/4/2021

Logged By: B. Rapp

Surface Elevation:



14835 SW 72nd Avenue
 Portland, Oregon 97224
 Tel: (503) 598-8445 Fax: (503) 941-9281

BORING LOG

Project: Chaney Frog Pond Property
 Willsonville, Oregon

Project No. 21-5743

Boring No. **B-6**

Depth (ft)	Sample Type	N-Value	Well Construction	Moisture Content (%)	Water Bearing Zone	Material Description
0 - 7		7				Soft, moderately organic SILT (OL-ML), brown, with roots, loose, moist (Topsoil Horizon)
7 - 10		10				Medium stiff to stiff, SILT (ML), light brown to gray, micaceous, subtle to strong orange and gray mottling, trace black staining, moist to wet (Willamette Formation)
10 - 11		7				
11 - 15		11				
15 - 16.5		39				Stiff to very stiff, silty CLAY to clayey SILT (CL-ML), light reddish brown, trace black staining, damp to moist (Residual Soil)
16.5 - 25		27				Boring Terminated at 16.5 feet. Groundwater Encountered at 2.5 Feet.

LEGEND



100 to 1,000 g
Bag Sample



Split-Spoon



Shelby Tube Sample



Static Water Table at Drilling



Static Water Table



Water Bearing Zone

Date Drilled: 3/4/2021

Logged By: B. Rapp

Surface Elevation:



14835 SW 72nd Avenue
 Portland, Oregon 97224
 Tel: (503) 598-8445 Fax: (503) 941-9281

BORING LOG

Project: Chaney Frog Pond Property
 Willsonville, Oregon

Project No. 21-5743

Boring No. **B-7**

Depth (ft)	Sample Type	N-Value	Well Construction	Moisture Content (%)	Water Bearing Zone	Material Description
0 - 3		3				Soft, moderately organic SILT (OL-ML), brown, with roots, loose, moist (Topsoil Horizon)
3 - 19		19				Medium stiff to stiff, SILT (ML), trace sand, light brown to gray, micaceous, subtle to strong orange and gray mottling, trace black staining, moist to wet (Willamette Formation)
19 - 12		12				
12 - 4		4			▼	
4 - 7		7				
7 - 16		16				Very stiff, silty CLAY to clayey SILT (CL-ML), light reddish brown, trace black staining, moist (Residual Soil)
16 - 16.5						Boring Terminated at 16.5 feet. Groundwater Encountered at 7 Feet.

LEGEND



Bag Sample



Split-Spoon



Shelby Tube Sample



Static Water Table at Drilling



Static Water Table



Water Bearing Zone

Date Drilled: 3/4/2021

Logged By: B. Rapp

Surface Elevation:

Exhibit I: Draft CC&Rs

AFTER RECORDING RETURN TO:
Venture Properties, Inc.
4230 Galewood Street, Suite 100
Lake Oswego, OR 97035

**DECLARATION OF
COVENANTS, CONDITIONS AND RESTRICTIONS
FOR FROG POND CROSSING**

THIS DECLARATION OF COVENANTS, CONDITIONS AND RESTRICTIONS FOR FROG POND CROSSING ("Declaration") is made by Venture Properties, Inc., an Oregon corporation ("Declarant").

RECITALS

Declarant is the owner of all the real property and improvements thereon located in the City of Wilsonville, County of Clackamas, State of Oregon, described as follows:

All Lots and Tracts as shown on the plat map of Frog Pond Crossing filed for record in the plat records of the County of Clackamas, State of Oregon and known collectively herein as "Frog Pond Crossing" (the "Property").

Declarant intends to develop Frog Pond Crossing as a Class I planned community within the meaning of the Oregon Planned Community Act. To establish Frog Pond Crossing as a planned community, Declarant desires to impose these mutually beneficial covenants, conditions, restrictions, easements, assessments and liens on the Property, under a comprehensive general plan of improvement and development for the benefit of all Lots and Common Area in Frog Pond Crossing.

Declarant has deemed it desirable for the efficient preservation of the values and amenities in Frog Pond Crossing to create a nonprofit corporation, to which will be delegated and assigned the powers and authority to own, maintain and administer the Common Area and facilities, maintain, repair and replace certain portions of the Property, to administer and enforce the covenants, conditions, and restrictions of this Declaration, and to collect and disburse the assessments and charges hereinafter created.

Declarant reserves the right to annex additional property ("Additional Property") in the future. Declarant may but shall have no obligation to annex all or any portion of the Additional Property to Frog Pond Crossing. After annexation, the Additional Property annexed shall constitute a part of Frog Pond Crossing and shall be subject to this Declaration. There is no limitation on the number of Lots and Tracts which may be annexed to Frog Pond Crossing.

NOW THEREFORE, Declarant declares that the Property shall be held, transferred, sold, conveyed and occupied subject to the Oregon Planned Community Act as may be amended from time to time (ORS 94.550 to 94.783) and subject to the following covenants, conditions, restrictions, easements, charges and liens, which shall run with the land, which shall be binding upon all parties having or acquiring any right, title or interest in the Property or any part thereof, and which shall inure to the benefit of the Association and of each Owner.

ARTICLE 1 DEFINITIONS

1.1 "Architectural Review Committee" or "ARC" shall refer to that committee constituted and acting pursuant to Article 6 of this Declaration.

1.2 "**Articles**" shall mean the Articles of Incorporation for the nonprofit corporation, Frog Pond Crossing Home Owners Association, as filed with the Oregon Secretary of State.

1.3 "**Association**" shall mean and refer to Frog Pond Crossing Home Owners Association, its successors and assigns.

1.4 "**Board**" shall mean the Board of Directors of the Association.

1.5 "**Bylaws**" shall mean and refer to the Bylaws of the Association which shall be recorded in Clackamas County, Oregon, deed records.

1.6 "**Common Area**" shall mean and refer to Tracts A, B, C and D as shown on the recorded Plat of the Property, including any improvements located thereon, which areas and improvements are intended to be devoted to the common use and enjoyment of the members' subject to the restrictions provided herein and which land shall be conveyed to the Association.

1.7 "**Commonly Maintained Property**" shall mean any property not owned by the Association, but for which the Association has maintenance responsibility, including but not limited to mailboxes.

1.8 "**Declaration**" shall mean the covenants, conditions, restrictions, and all other provisions set forth in this Declaration.

1.9 "**Declarant**" shall mean and refer to Venture Properties, Inc., an Oregon limited liability company, and its successors or assigns, or any successor or assign to all or the remainder of its interest in the Property. Without limiting the generality of the foregoing, Declarant shall have the right to assign some or all of its Declarant rights hereunder to a purchaser of Lots, and such assignees shall be successor Declarants to the extent of such assignment(s).

1.10 "**General Plan of Development**" shall mean Declarant's general plan of development of the Property, as approved by appropriate governmental agencies, as may be amended from time to time.

1.11 "**Frog Pond Crossing**" shall mean Lots 1-29 of the Property and Tracts A, B, C and D as designated on the plat of Frog Pond Crossing and may include an undetermined number of additional lots that may be annexed in the future.

1.12 "**Home**" shall mean and refer to any portion of a structure situated on a Lot and designed and intended for use and occupancy as a residence.

1.13 "**Lot**" shall mean and refer to each and any of the Lots on the plat of Frog Pond Crossing. "Lot" shall not include any of the Tracts.

1.14 "**Members**" shall mean and refer to the Owners of Lots in Frog Pond Crossing.

1.15 "**Occupant**" shall mean and refer to the occupant of a Home, whether such person is an Owner, a lessee or any other person authorized by the Owner to occupy the Home.

1.16 "**Owner**" shall mean and refer to the record owner, whether one or more persons or entities, of the fee simple title to any Lot or a purchaser in possession of a Lot under a land sale contract. The foregoing does not include persons or entities that hold an interest in any Lot merely as security for the performance of an obligation.

1.17 "**Plat**" shall mean and refer to the Plat of Frog Pond Crossing recorded in the Plat Records of Clackamas County, Oregon, and any subsequent plats for future phases of Frog Pond Crossing annexed into this Declaration, together with any amendments to any of the foregoing.

1.18 "**Property**" shall have the meaning attributed to such term in the Recitals of this Declaration.

1.19 "**Reserve Account(s)**" shall mean and refer to an account set up by the Board to hold funds for construction, improvements or maintenance of the Common Area and the Commonly Maintained Property.

1.20 "**Rules and Regulations**" shall mean and refer to the documents containing rules and regulations and policies adopted by the Board or the Architectural Review Committee, as may be from time to time amended.

1.21 "**Tract(s)**" shall mean and refer to Tracts A, B, C and D as shown on the Plat.

ARTICLE 2

PROPERTY SUBJECT TO THIS DECLARATION

2.1 **Development.** The development of Frog Pond Crossing shall consist of the Property, which shall be held, transferred, sold, conveyed, and occupied subject to this Declaration. Declarant does not intend to build any Common Area improvements in Frog Pond Crossing, except as provided herein.

2.2 **Right to Annex Additional Property or to Withdraw Property.** The Declarant reserves the right to annex additional property to or to withdraw property from Frog Pond Crossing.

ARTICLE 3

OWNERSHIP AND EASEMENTS

3.1 **Non-Severability.** The interest of each Owner in the use and benefit of the Common Area shall be appurtenant to the Lot owned by the Owner. No Lot shall be conveyed by the Owner separately from the interest in the Common Area. Any conveyance of any Lot shall automatically transfer the right to use the Common Area without the necessity of express reference in the instrument of conveyance. There shall be no judicial partition of the Common Area. Each Owner, whether by deed, gift, devise or operation of law, for such Owner's benefit and for the benefit of all other Owners, specifically waives and abandons all rights, interests and causes of action for judicial partition of any interest in the Common Area and agrees that no action for judicial partition shall be instituted, prosecuted or reduced to judgment. Ownership interests in the Common Area and Lots are subject to the easements granted and reserved in this Declaration.

Each of the easements granted or reserved herein shall be deemed to be established upon the recordation of this Declaration and shall thenceforth be deemed to be covenants running with the land for the use and benefit of the Owners and their Lots and shall be superior to all other encumbrances applied against or in favor of any portion of Frog Pond Crossing.

3.2 Ownership of Lots. Title to each Lot in Frog Pond Crossing shall be conveyed in fee to an Owner. If more than one person and/or entity owns an undivided interest in the same Lot, such persons and/or entities shall constitute one Owner.

3.3 Ownership of Common Area. Subject to subsection 3.5, title to any Common Area shall be conveyed to the Association not later than the date of the Turnover Meeting.

3.4 Easements. Individual deeds to Lots may, but shall not be required to, set forth the easements specified in this Article.

3.4.1 Easements on Plat. The Common Area and Lots are subject to the easements and rights-of-way shown on the Plat, including, without limitation, Public Utility Easements, storm sewer, surface water, drainage, detention, sidewalk and public access easements.

3.4.2 Easements for Common Area. Subject to the restrictions contained herein, every Owner shall have a non-exclusive right and easement of use and enjoyment in and to the Common Area, which shall be appurtenant to and shall pass with the title to every Lot. Such easement is subject to ORS 94.665, as may be amended from time to time.

3.4.3 Easements Reserved by Declarant. So long as Declarant owns any Lot, Declarant reserves an easement over, under and across the Common Area in order to carry out sales activities necessary or convenient for the sale of Lots. Declarant, for itself and its successors and assigns, hereby retains a right and easement of ingress and egress to, from, over, in, upon, under and across the Common Area and the right to store materials thereon and to make such other use thereof as may be reasonably necessary or incident to the construction of the improvements on the Property in such a way as not to interfere unreasonably with the occupancy, use, enjoyment or access to an Owner's Lot by such Owner or such Owner's family, tenants, employees, guests or invitees.

3.4.4 Additional Utility and Drainage Easements. Notwithstanding anything expressed or implied to the contrary, this Declaration shall be subject to all easements granted or acquired by Declarant for the installation and maintenance of utilities and drainage facilities necessary for the development of Frog Pond Crossing. No structure, planting or other material that may damage or interfere with the installation or maintenance of utilities, that may change the direction of flow of drainage channels in the easements, or that may obstruct or retard the flow of water through drainage channels in the easement areas shall be placed or permitted to remain within any easement area.

3.4.5 Association's Right of Entry. Declarant grants to the Association and its duly authorized agents and representatives such right of entry over the Lots and Common Area as are necessary to perform the duties and obligations of the Association, as set forth in this Declaration, the Bylaws, and the Articles, as the same may be amended.

3.4.6 Easement to Governmental Entities. Declarant grants a non-exclusive easement over the Common Area to all governmental and quasi-government entities, agencies, utilities, and their agents for the purposes of performing their duties as utility providers.

3.4.7 Perimeter Right of Entry Benefiting Association. Declarant grants to the Association and its duly authorized agents and representatives a right of entry over that perimeter portion of each Lot that is included within the building setbacks set by applicable ordinances for the purposes of installation, maintenance, repair, and replacement of private streets, Common Area, Commonly Maintained Property, utilities, communication lines, and drainage. The Board may grant or convey the easements reserved herein to any governmental body or agency and/or any public or private utility company or provider, upon a two-thirds (2/3) vote of the Board members at a duly called and held Board meeting.

3.5 Declarant's Right to Dedicate Common Area and Grant Easements; Board's Authority After Title Transferred to Association. Declarant reserves the right and power to dedicate and/or convey any portion or all of the Tracts to any governmental body or agency without the approval of any other Owner or the Association. Declarant further reserves the right and power to grant an easement over the Tracts to any governmental body or agency or any public or private utility company or provider without the approval of any other Owner or the Association. Declarant's rights and power under this Section 3.5 shall expire when the Tracts are conveyed to the Association. Thereafter, the Board shall have the same powers reserved to Declarant and may exercise such power upon a two-thirds (2/3) or greater vote of the Board members at any duly called and held Board meeting. The provisions of this Section 3.5 shall control over any provisions to the contrary contained in any other Section of the Declaration.

ARTICLE 4 **LOTS AND HOMES**

4.1 Residential Use. Lots shall only be used for residential purposes. Except with the Board's consent no trade, craft, business, profession, commercial or similar activity of any kind shall be conducted on any Lot or in any Home, and no goods, equipment, vehicles, materials or supplies used in connection with any trade, service or business shall be kept or stored on any Lot or in any Home. Nothing in this Section 4.1 shall be deemed to prohibit (a) activities relating to the sale of residences, (b) the right of Declarant or any contractor or homebuilder to construct residences on any Lot, to store construction materials and equipment on such Lots in the normal course of construction, and to use any residence as a sales office or model home for purposes of sales in Frog Pond Crossing, and (c) the right of the Owner of a Lot to maintain such Owner's personal business or professional library, keep such Owner's personal business or professional records or accounts, handle such Owner's personal business or professional telephone calls or confer with a reasonable number of business or professional associates, clients or customers in such Owner's residence. The Board shall not approve commercial activities otherwise prohibited by this Section 4.1 unless the Board determines that only normal residential activities would be observable outside of the residence and that the activities would not be in violation of applicable local government ordinances.

4.2 Construction of Homes. Except as provided in Section 6.15, no construction of a Home or any other structure shall occur on a Lot unless the approval of the ARC is first obtained

as provided in Article 6. Considerations such as siting, shape, size, color, design, height, solar access, or material may be considered by the ARC in determining whether or not to consent to any proposed work. The following restrictions are required for all Lots:

4.2.1 Lot Coverage. The total square footage of a Lot that may be covered by any type of structure may not be any more than permitted by applicable zoning ordinances and the variances allowed by the land use approval for the Property.

4.2.2 Setbacks. All Homes within Frog Pond Crossing shall comply with City of Wilsonville setback requirements and such other setbacks as established or permitted by Clackamas County and all other governing authorities, the Architectural Standards and by the ARC after a review of all relevant data.

4.3 Completion of Construction. The construction and landscaping of any building on any Lot, including painting and all exterior finish and landscaping, shall be completed within twelve (12) months from the beginning of the construction so as to present a finished appearance when viewed from any angle. In the event of undue hardship due to weather conditions or other factors, this provision may be extended for a reasonable length of time upon written approval from the ARC. If construction has not commenced within twelve (12) months after the construction documents have been approved by the ARC, the approval shall be deemed revoked unless the Owner has applied for and received an extension of time in writing from the ARC.

4.4 Landscaping. Landscaping for front yard portions of the Lot shall be completed within three (3) months after occupancy of the Home. The Declarant or other Owner of any Lot with finished Homes being held for sale shall complete front yard landscaping on such Lot within three (3) months after substantial completion of such Home. Owners shall irrigate their entire yard to keep lawns green and other landscaping fresh. Street trees in front of an Owner's Home shall be irrigated and maintained by such Owner as required by the City of Wilsonville or any other governing jurisdiction. Owners shall not remove or move street trees.

4.5 Maintenance of Lots and Homes. Each Owner shall maintain such Owner's Lot and all improvements thereon in a clean and attractive condition, in good repair and in such fashion as not to create a fire hazard. Such maintenance shall include, without limitation, maintenance of roofs, siding, windows, doors, garage doors, walks, patios, chimneys, landscaping, street trees (if not maintained by the Association or a sub-association), and other exterior improvements and glass surfaces, including, without limitation, any sidewalk abutting such Owner's Lot, as required by City of Wilsonville ordinances. All repainting or re-staining and exterior remodeling shall be subject to prior review and approval by the ARC. Each Owner shall repair damage caused to such Owner's Lot or improvements located thereon by fire, flood, storm, earthquake, riot, vandalism, or other causes within a reasonable period.

4.6 Rental of Homes. An Owner may rent or lease such Owner's Home or a portion thereof, provided that the following conditions are met:

4.6.1 Written Rental Agreements Required. The Owner and the tenant shall enter into a written rental or lease agreement specifying that (i) the tenant shall be subject to all provisions of the Declaration, Bylaws and Rules and Regulations, and (ii) a failure to comply with

any provision of the Declaration, Bylaws and Rules and Regulations shall constitute a default under the rental or lease agreement.

4.6.2 Minimum Rental Period. The period of the rental or lease is not less than thirty (30) days.

4.8.3 Tenant Must be Given Documents. The Owner gives each tenant a copy of the Declaration, Bylaws and Rules and Regulations.

4.7 Animals. No animals, livestock or poultry of any kind, other than a reasonable number of dogs and cats that are not kept, bred or raised for commercial purposes and that are reasonably controlled so as not to be a nuisance, shall be raised, bred, kept or permitted within any Lot. Excluded from the foregoing restriction shall be birds, fish, small reptiles, and small animals which are kept in cages or tanks which are permanently kept within the interior of a Home. Owners whose pets cause any inconvenience or unpleasantness to other Owners shall take all steps reasonably necessary to prevent recurrence thereof and Owners whose pets damage other Owners' Lots or personal property shall reimburse such other Owners for reasonable costs actually incurred by such other Owners in repairing such damage. An Owner shall ensure that such Owner's dog is leashed when on the Property and outside of such Owner's Lot. An Owner may be required to remove a pet upon the receipt of the third notice in writing from the Board of a violation of any rule, regulation, or restriction governing pets within the Property.

4.8 Nuisance. No noxious, harmful, or offensive activities shall be carried on upon any Lot or Common Area. Nor shall anything be done or placed on any Lot or Common Area that interferes with or jeopardizes the enjoyment of, or that is a source of annoyance to, the Owner or other Occupants. No outside burning of leaves, debris, trash, garbage, or household refuse shall be permitted.

4.9 Parking. Boats, trailers, commercial vehicles, mobile homes, campers, and other recreational vehicles or equipment, regardless of weight, shall not be parked on any part of the Common Area, or on any streets on or adjacent to the Property at any time or for any reason, including loading or unloading, and may not be parked on any Lot, including the driveway, for more than three (3) days unless they are fully enclosed in the garage or parked alongside the Home and fully obscured from view behind a fully enclosed fence which may not extend beyond the front of the Home or garage. Owners must obtain prior approval to install such screening fence from the ARC.

4.10 Vehicles in Disrepair. No Owner shall permit any vehicle that is in a state of disrepair (e.g. including, but not limited to, fails to run, cannot be moved under its own power in current condition, flat tires, unpainted or body parts missing) or that is not currently licensed to be abandoned or to remain parked upon the Common Area or on any street on or adjacent to the Property at any time and may not permit them on a Lot for a period in excess of three (3) days. A vehicle shall be deemed in a "state of disrepair" when the Board reasonably determines that its presence offends the occupants of the neighborhood. If an Owner fails to remove such vehicle within forty-eight (48) hours following the date on which the Association mails or delivers to such Owner a notice directing such removal, the Association may have the vehicle removed from the Property and charge the expense of such removal to the Owner as an Assessment, which may be collected and enforced as any other assessments imposed pursuant to the Declaration and Bylaws.

4.11 Signs. No signs shall be erected or maintained on any Lot except that not more than one (1) "For Sale" or "For Rent" sign placed by the Owner or by a licensed real estate agent, not exceeding twenty-four (24) inches high and thirty-six (36) inches long, may be temporarily displayed on any Lot. The restrictions contained in this Section 4.14 shall not prohibit the temporary placement of "political" signs on any Lot by the Owner or Occupant. Provided, however, political signs shall be removed within three (3) days after the election day pertaining to the subject of the sign. Real estate signs shall be removed within three (3) days after the sale closing date.

4.12 Rubbish and Trash. No Lot or part of the Common Area shall be used as a dumping ground for trash or rubbish of any kind. All garbage and other waste shall be kept in appropriate containers for proper disposal, which shall be screened or otherwise kept out of public view. Yard rakings, dirt and other material resulting from landscaping work shall not be dumped onto streets, the Common Area, or any other Lots. If an Owner fails to remove any trash, rubbish, garbage, yard rakings or any similar materials from any Lot, any streets or the Common Area where deposited by such Owner or the Occupants of such Owner's Lot after notice has been given by the Board to the Owner, the Association may have such materials removed and charge the expense of such removal to the Owner. Such charge shall constitute an Assessment, which may be collected and enforced as any other assessments imposed pursuant to the Declaration and Bylaws.

4.13 Fences and Hedges. Except for construction performed by or contracted for by Declarant, no fences or boundary hedges shall be installed or replaced without prior written approval of the ARC. Rear yard fences shall be six (6) feet tall or less and no fence will extend beyond the front elevation of the home. All fencing on corner lots shall comply with any applicable City of Wilsonville vision clearance requirements, which may limit fence heights and may regulate fence locations.

All fences, excluding fencing installed during the development of Frog Pond Crossing, will conform to the style outlined in Exhibit "A" of this document and must be stained Sherwin Williams SW 3524 "Chestnut" unless otherwise approved by the ARC Committee.

4.14 Service Facilities. Service facilities (garbage containers, fuel tanks, clotheslines, etc.) shall be screened such that such facilities are not visible at any time from the street except the night before and during garbage pickup days. All telephone, electrical, cable television and other utility installations shall be placed underground in conformance with applicable law and subject to approval by the ARC.

4.15 Antennas and Satellite Dishes. Except as otherwise provided by law or this Section, no exterior antennas, satellite dishes, microwave, aerial, tower or other devices for the transmission or reception of television, radio or other forms of sound or electromagnetic radiation shall be erected, constructed or placed on any Common Area or Lot. Without prior written consent from the ARC, exterior satellite dishes or antennas with a surface diameter of one (1) meter or less and antennas designed to receive television broadcast signals or multi-channel multi-point distribution (wireless cable) only may be placed on any Lot if they are not visible from the street and are screened from neighboring Lots to the extent possible. The Board or ARC may adopt reasonable rules and regulations governing the installation, safety, placement and screening of such antennas, satellite dishes and other transmission devices. Such rules shall not unreasonably

delay or increase the cost of installation, maintenance or use or preclude reception of a signal of acceptable quality.

4.16 Exterior Lighting or Noise-Making Devices. Except with the consent of the ARC, no exterior lighting or noise-making devices, other than security and fire alarms, shall be installed or maintained on any Lot.

4.17 Basketball Hoops. No Owner may install a permanent basketball hoop on any Lot without the ARC's prior approval. The ARC may, in its discretion, prohibit such basketball hoops. Basketball hoops shall be prohibited in the Common Area and on any Lot if the area of play is intended to be the street or any Common Area. When not in use, temporary or portable basketball hoops must be stored or screened from view.

4.18 Grades, Slopes and Drainage. There shall be no interference with the established drainage patterns or systems over or through any Lot within Frog Pond Crossing so as to affect any other Lot or Common Area or any real property outside Frog Pond Crossing unless adequate alternative provision is made for proper drainage and is approved by the ARC. The term "established drainage" shall mean the drainage swales, conduits, inlets, and outlets designed and constructed for Frog Pond Crossing.

4.19 Damage or Destruction to Home and/or Lot. If all or any portion of a Lot or Home is damaged by fire or other casualty, the Owner shall either (i) restore the damaged improvements or (ii) remove all damaged improvements, including foundations, and leave the Lot in a clean and safe condition. Any restoration proceeding under (i) above must be performed so that the improvements are in substantially the same condition in which they existed prior to the damage, unless the provisions of Article 6 are complied with by the Owner. The Owner must commence such work within sixty (60) days after the damage occurs and must complete the work within six (6) months thereafter.

4.20 Right of Maintenance and Entry by Association. If an Owner fails to perform maintenance and/or repair that such Owner is obligated to perform pursuant to this Declaration, and if the Board determines, after notice, that such maintenance and/or repair is necessary to preserve the attractiveness, quality, nature and/or value of Frog Pond Crossing, the Board may cause such maintenance and/or repair to be performed and may enter any such Lot whenever entry is necessary in connection with the performance thereof. An Owner may request, and the Board shall conduct, a hearing on the matter. The Owner's request shall be in writing delivered within five (5) days after receipt of the notice, and the hearing shall be conducted within not less than five (5) days nor more than twenty (20) days after the request for a hearing is received. Entry shall be made with as little inconvenience to an Owner as practicable and only after advance written notice of not less than forty-eight (48) hours, except in emergency situations. The costs of such maintenance and/or repair shall be chargeable to the Owner of the Lot as an Assessment, which may be collected and enforced as any other assessments authorized hereunder.

4.21 Association Rules and Regulations. The Board from time to time may adopt, modify or revoke such Rules and Regulations governing the conduct of persons and the operation and use of Lots and the Common Area as it may deem necessary or appropriate to assure the peaceful and orderly use and enjoyment of the Property and the administration and operation of the Association. A copy of the Rules and Regulations, upon adoption, and a copy of each

amendment, modification or revocation thereof, shall be delivered by the Board promptly to each Owner and shall be binding upon all Owners and occupants of all Lots upon the date of delivery or actual notice thereof. The method of adoption of such Rules and Regulations shall be provided in the Bylaws of the Association. Subject to approval or consent by the Board, the ARC may adopt rules and regulations pertinent to its functions.

4.22 Ordinances and Regulations. The standards and restrictions set forth in this Article 4 shall be the minimum required. To the extent that local governmental ordinances and regulations are more restrictive or provide for a higher or different standard, such local governmental ordinances and regulations shall prevail.

4.23 Temporary Structures. No structure of a temporary character or any trailer, basement, tent, shack, garage, barn, or other outbuilding shall be used on any Lot as a residence, either temporarily or permanently.

4.24 Declarant Exemptions. Any home builder building a home for sale to a third party and the Declarant shall be exempt from the application of Section 4.14.

ARTICLE 5

COMMON AREA AND COMMONLY MAINTAINED PROPERTY

5.1 Common Area Tracts. Tract A is for natural resources and open space. Tract B is for private alley access serving lots 17-24. Tract C is for pedestrian and bicycle access. Tract D is for landscaping and open space.

5.2 Easements. Lots 1-16 and 25-29 are subject to 6-foot public utility easements along their front-lot street frontages. Lots 1, 5, 10, 12, 17 and 24 are subject to 6-foot public utility easements along their side-lot street frontages. Tracts A, B and C are subject to 6-foot public utility easements at their frontages on **Local Street A**. Portions of lots 21, 22 and 25 and portions of Tracts A, B and D are subject to a BPA transmission line easement.

5.3 Use of Common Areas. Use of the Common Area is subject to the provisions of the Declaration, Bylaws, Articles and the Rules and Regulations adopted by the Board. There shall be no obstruction of any part of the Common Area. Nothing shall be stored or kept in the Common Area without the prior written consent of the Board. No alterations or additions to the Common Area shall be permitted without the prior written consent of the Board. The Common Area owned by the Association consists solely of the Tracts.

5.4 Maintenance of Common Area and Commonly Maintained Property. Except as otherwise specifically provided in this Declaration, the Association shall be responsible for maintenance, repair, replacement, and upkeep of the Common Area and Commonly Maintained Property. The Association shall keep the Common Area in good condition and repair, provide for all necessary services, and cause all acts to be done which may be necessary or proper to assure the maintenance of the Common Area.

5.5 Alterations to Common Area. Except as otherwise specifically provided in this Declaration, only the Association shall construct, reconstruct, or alter any improvement located on

the Common Area. A proposal for any construction of or alteration, maintenance, or repair to any such improvement may be made at any Board meeting. A proposal may be adopted by the Board, subject to the limitations contained in the Bylaws, this Declaration.

5.6 Funding. Expenditures for alterations, maintenance, or repairs to an existing improvement for which a reserve has been collected shall be made from the Reserve Account. As provided in Section 10.4, the Board may levy a special assessment to fund any construction, alteration, repair or maintenance of an improvement (or any other portions of the Common Area and Commonly Maintained Property) for which no reserve has been collected or for which the Reserve Account is insufficient to cover the cost of the proposed improvement.

5.7 Landscaping. All landscaping on any Lot, the Common Area or Commonly Maintained Property shall be maintained and cared for in a manner that is consistent with Declarant's or the ARC's original approval of such landscaping. Weeds and diseased or dead lawn, tree, ground cover or shrubs shall be removed and replaced. Lawns shall be neatly mowed, and trees and shrubs shall be neatly trimmed. All landscaping shall be irrigated in a horticulturally proper manner, subject to water use restrictions or moratoria by government bodies or agencies.

5.8 Condemnation of Common Area. If all or any portion of the Common Area is taken for any public or quasi-public use under any statute, by right of eminent domain or by purchase in lieu of eminent domain, the entire award shall be received by and expended by the Board in a manner that, in the Board's discretion, is in the best interest of the Association and the Owners. The Association shall represent the interest of all Owners in any negotiations, suit, action, or settlement in connection with such matters.

5.9 Damage or Destruction of Common Area. If all or any portion of the Common Area or Commonly Maintained Property is damaged or destroyed by an Owner or any of Owner's guests, Occupants, tenants, licensees, agents or members of Owner's family in a manner that would subject such Owner to liability for such damage under Oregon law, such Owner hereby authorizes the Association to repair such damage. The Association shall repair the damage and restore the area in workmanlike manner as originally constituted or as may be modified or altered subsequently by the Association in the discretion of the Board. Reasonable costs incurred in connection with affecting such repairs shall become a special assessment upon the Lot and against the Owner who caused or is responsible for such damage.

5.10 Power of Association to Sell, Convey or Grant Security Interest in Common Area. The Association may sell, convey, or subject to a security interest any portion of the Common Area pursuant to the processes and limitations set forth in ORS 94.665.

5.11 Public Use of Lands. ORS 105.672 through 105.700 exculpate owners of lands who allow the general public upon their lands for purposes of recreation, and the liability of the Declarant and the Association and its members shall be limited as provided thereby.

ARTICLE 6 **ARCHITECTURAL REVIEW COMMITTEE**

6.1 Architectural Review. Except as provided in Section 6.15, no improvement shall be commenced, erected, placed or altered on any Lot until the construction plans and specifications showing the nature, shape, heights, materials, colors, and proposed location of the improvement have been submitted to and approved in writing by the ARC. This Article's purpose is to ensure quality of workmanship and materials and harmony between exterior design and the existing improvements and landscaping and as to location with respect to topography and finished grade elevations. The ARC shall not be responsible for determining compliance with structural and building codes, solar ordinances, zoning codes or other governmental regulations, all of which are the applicant's responsibility. The procedure and specific requirements for review and approval of construction shall be set forth in design guidelines and standards adopted from time to time by the ARC. The provisions of this Article shall apply in all instances in which this Declaration requires the ARC's consent.

6.2 Architectural Review Committee, Appointment and Removal. Declarant reserves the right to appoint all members of the ARC and all replacements thereto until Frog Pond Crossing is one hundred percent (100%) built out. Each ARC member shall serve for one (1) year. After build-out, the Board shall have the right to appoint and remove members of the ARC. After the right to appoint the members of the ARC transfers to the Board, the ARC shall consist of three (3) members. The Board may appoint itself as the ARC or any of its members to the ARC. If an ARC has not been appointed, the Board shall serve as the ARC.

6.3 Majority Action. Except as otherwise provided in this Declaration, a majority of the members of the ARC shall have the power to act on behalf of the ARC, without the necessity of a meeting and without the necessity of consulting the remaining member or members of the ARC. The ARC may render its decision only by written instrument setting forth the action taken by the members consenting thereto.

6.4 Duties. The ARC shall consider and act upon the proposals and/or plans submitted pursuant to this Article. The ARC, from time to time and at its sole discretion, may adopt architectural rules, regulations, and guidelines ("Architectural Standards").

6.5 ARC Decision. The ARC shall render its written decision approving or denying each application submitted to it within thirty (30) working days after its receipt of all materials required with respect to such application. If appeals are permitted pursuant to Section 6.8, a decision will not be final until the 10-day appeal period has expired, or, if an appeal is timely filed, when the Board issues a decision on the appeal. If the ARC fails to render such written decision within thirty (30) days of its receipt of all required materials or request an extension, the application shall be deemed approved. The ARC shall be entitled to request one or more extensions of time, not to exceed thirty (30) days. In the event of such extension requests, if the ARC does not render a written decision within the extension period, the application shall be deemed approved. Provided, however, the applicant may agree to further extensions to allow the applicant to complete or supplement the application.

6.6 ARC Discretion. The ARC, at its sole discretion, may withhold consent to any proposed work if the ARC finds the proposed work would be inappropriate for the particular lot or incompatible with the design standards that the ARC intends for Frog Pond Crossing. The ARC may consider siting, shape, size, color, design, height, solar access or other effect on the enjoyment

of other Lots or the Common Area, and any other factors that it reasonably believes to be relevant in determining whether or not to consent to any proposed work.

6.7 Nonwaiver. Consent by the ARC to any matter proposed to it or within its jurisdiction shall not be deemed to constitute precedent or waiver impairing its right to withhold approval as to any similar matter thereafter proposed or submitted to it for consent.

6.8 Appeal. After the right to appoint ARC members transfers to the Board, pursuant to Section 6.2, any Owner adversely impacted by action of the ARC may appeal such action to the Board. Such appealing Owner shall submit to the Board a written notice of appeal, setting forth specific objections or mitigating circumstances justifying the appeal, to the Board within ten (10) days after the ARC's action. The Board shall issue a final, conclusive decision within forty-five (45) days after receipt of such notice, and such decision shall be final and binding upon the appealing Owner, the Owner of the affected Lot, and the ARC. Provided, however, the Board shall make reasonable efforts to reach a decision within twenty (20) days. If the Board is serving as the ARC, then such appeal shall be deemed a request for reconsideration.

6.9 Effective Period of Consent. Except as provided in Section 4.3, the ARC's consent to any proposed work shall automatically expire six (6) months after issuance unless construction of the project has been commenced or the Owner has applied for and received an extension of time from the ARC.

6.10 Determination of Compliance. The ARC may inspect, from time to time, all work performed and determine whether it is in substantial compliance with the approval granted. If the ARC finds that the work was not performed in substantial conformance with the approval granted, or if the ARC finds that the approval required was not obtained, the ARC shall notify the Owner in writing of the noncompliance. The notice shall specify the particulars of noncompliance and shall require the Owner to remedy the noncompliance.

6.11 Noncompliance. If the ARC determines that an Owner has not constructed an improvement consistent with the specifications of an ARC approval or has constructed an improvement without obtaining ARC approval, sends a notice of noncompliance to such Owner, and such Owner fails to commence diligently remedying such noncompliance in accordance with such notice, then, effective at 5 p.m. on the third (3rd) day after issuance of such notice, the ARC shall provide notice of a hearing to consider the Owner's continuing noncompliance. The hearing shall be set not more than thirty (30) days from the date on which the notice of noncompliance was issued. At the hearing, if the ARC finds that there is no valid reason for the continuing noncompliance, the ARC shall determine the estimated costs of achieving compliance and may issue a fine against the noncomplying Owner for such amount. The ARC also shall require the Owner to remedy such noncompliance within ten (10) days after the date of the ARC's determination. If the Owner does not comply with the ARC's ruling within such period or any extension thereof granted by the ARC, at its sole discretion, the ARC may remove the noncomplying improvement, remedy the noncompliance, and/or record a notice of noncompliance in the county deed records. The costs of any such action shall be assessed against the Owner as a Reimbursement Assessment either before or after any remedial action is taken.

6.12 Liability. Neither the ARC nor any member thereof shall be liable to any Owner, Occupant, for any damage, loss or prejudice suffered or claimed on account of any action or failure

to act of the ARC or a member thereof, provided only that the ARC or the member has, in accordance with its or his actual knowledge, acted in good faith.

6.13 Estoppel Certificate. Within fifteen (15) working days after the ARC's receipt of a written request from an Owner and the ARC's receipt of payment of a reasonable fee fixed by the ARC to cover costs, the ARC shall provide such Owner with a certificate executed by the Chairperson or other authorized member of the ARC certifying with respect to any Lot owned by the Owner, that, as of the date thereof either (a) all improvements made or done upon such Lot comply with this Declaration, or (b) such improvements do not so comply, in which event, the certificate shall also identify the noncomplying improvements and set forth with particularity the nature of such noncompliance. The Owner and such Owner's heirs, devisees, successors, and assigns shall be entitled to rely on the certificate with respect to the matters set forth therein. The certificate shall be conclusive as among Declarant, the ARC, the Association, all Owners, and all persons deriving any interest through any of them.

6.14 Fees. The ARC may charge applicants a reasonable application fee and additional costs incurred or expected to be incurred by the ARC to retain architects, attorneys, engineers and other consultants to advise the ARC concerning any aspect of the applications and/or compliance with any appropriate architectural criteria or standards. Such fees shall be collectible as assessments pursuant to Article 10.

6.15 Declarant and Successor Exempt From ARC. The Declarant or a successor shall be exempt from the requirement to submit and have plans approved by the ARC.

ARTICLE 7

MEMBERSHIP IN THE ASSOCIATION

7.1 Members. Each Owner shall be a member of the Association. Membership in the Association shall be appurtenant to, and may not be separated from, ownership of any Lot. Transfer of ownership of a Lot shall automatically transfer membership in the Association. Without any other act or acknowledgment, Occupants and Owners shall be governed and controlled by this Declaration, the Articles, Bylaws, and the Rules and Regulations of the Association and any amendments thereof.

7.2 Proxy. Each Owner may cast such Owner's vote in person, by written ballot or pursuant to a proxy executed by such Owner. An Owner may not revoke a proxy given pursuant to this Section 7.2 except by actual notice of revocation to the person presiding over a meeting of the Association. A proxy shall not be valid if it is undated or purports to be revocable without notice. A proxy shall terminate one (1) year after its date unless the proxy specifies a shorter term.

7.3 Voting Rights. The Association shall have two (2) classes of voting members:

7.3.1 Class A. Class A members shall be all Owners of Lots other than Declarant, and each Class A member shall be entitled to one (1) vote for each Lot owned with respect to all matters upon which Owners are entitled to vote.

7.3.2 Class B. The Class B member shall be Declarant, its successors, and assigns. The Class B member shall have three (3) votes for each Lot owned. The Class B

membership shall cease and be converted to Class A membership upon the earlier of the following dates (the "Termination Date"):

(a) When all Lots are sold from the Declarant to a party other than a successor Declarant; or

(b) At such earlier time as Declarant elects in writing to terminate Class B membership.

After the Termination Date, each Owner, including Declarant, shall be entitled to one (1) vote for each Lot owned with respect to all matters upon which Owners are entitled to vote, and the total number of votes shall be equal to the total number of Lots subject to this Declaration.

When more than one (1) person or entity owns a Lot, the vote for such Lot may be cast as they shall determine, but in no event shall fractional voting be allowed. Fractional or split votes shall be disregarded, except for purposes of determining a quorum.

7.4 Procedure. All meetings of the Association, the Board, the ARC, and Association committees shall be conducted with such rules of order as may from time to time be adopted by the Board. Notwithstanding which rule of order is adopted, the President shall be entitled to vote on all matters, not merely to break a tie vote. A tie vote does not constitute a majority or approval of any motion or resolution.

ARTICLE 8 **DECLARANT CONTROL**

8.1 Interim Board and Officers. Declarant hereby reserves administrative control of the Association. Declarant, in its sole discretion, shall have the right to appoint and remove members of an interim board (the "Interim Board"), which shall manage the affairs of the Association and be invested with all powers and rights of the Board until the Turnover Meeting (as hereinafter defined). The Interim Board shall consist of from one (1) to three (3) members. Notwithstanding the provision of this Section 8.1, at the Turnover Meeting, at least one (1) Director shall be elected by Owners other than Declarant, even if Declarant otherwise has voting power to elect all three (3) Directors.

8.2 Turnover Meeting. Declarant shall call a meeting for the purpose of turning over administrative control of the Association from Declarant to the Class A members within sixty (60) days of the earlier of the following dates:

8.2.1 Latest Date. When all Lots are sold from Declarant to someone other than a successor Declarant; or

8.2.2 Optional Turnover. At such time as Declarant has elected in writing to terminate Class B membership.

Declarant shall give notice of the Turnover Meeting to each Owner as provided in the Bylaws. If Declarant does not call the Turnover Meeting required under this Section, the transitional advisory committee or any Owner may do so.

8.3 Transitional Advisory Committee. Not later than the sixtieth (60th) day after the date the Declarant conveys at least fifty percent (50%) of the Lots in the Project, the Declarant shall call a meeting of Owners for the purpose of electing a Transitional Advisory Committee. The Transitional Advisory Committee shall consist of three (3) members, two of whom shall be selected by Owners other than the Declarant, and one of whom shall be appointed by the Declarant. The Committee shall have reasonable access to the same information and documents that the Declarant is required to deliver to the Association at the Turnover Meeting. An Owner may call the meeting provided for in this Section 8.3 if the Declarant fails to do so.

ARTICLE 9 **DECLARANT'S SPECIAL RIGHTS**

9.1 General. Declarant is undertaking the work of developing Lots and other improvements within Frog Pond Crossing. The completion of the development work and the marketing and sale of the Lots is essential to the establishment and welfare of the Property as a residential community. Until the Homes on all Lots on the Property have been constructed, fully completed and sold, with respect to the Common Area and each Lot on the Property, Declarant shall have the special rights set forth in this Article 9.

9.2 Marketing Rights. Declarant shall have the right to maintain a sales office and model on one or more of the Lots which Declarant owns. Declarant and prospective purchasers and their agents shall have the right to use and occupy the sales office and models during reasonable hours any day of the week. Declarant may maintain a "For Sale" and community marketing signs at reasonable locations on the Property, including, without limitation, on the Common Area.

9.3 Declarant Easements. Declarant reserves easements over the Property as more fully described in Sections 3.4 and 3.5 hereof.

9.4 Additional Improvements. Declarant has not committed to build any improvements not described in this Declaration.

9.5 Control of the ARC. Declarant shall have the right, but not the obligation, to control all aspects of the ARC, including the appointment of all ARC members and the approval, modification or adoption of the Architectural Standards as described in Article 6 herein.

ARTICLE 10 **FUNDS AND ASSESSMENTS**

10.1 Purpose of Assessments; Expenses. The assessments levied by the Association shall be used exclusively to promote the recreation, health, safety, aesthetics and welfare of the Owners and Occupants of Frog Pond Crossing, for the improvement, operation and maintenance of the Common Area and the Commonly Maintained Property, for the payment of obligations of the Association, for the administration and operation of the Association and for property and liability insurance.

10.2 Covenants to Pay. Each Owner covenants and agrees to pay the Association the assessments and any additional charges levied pursuant to this Declaration or the Bylaws. All

assessments for operating expenses, repairs and replacement and reserves shall be allocated among the Lots and their Owners as set forth in Section 10.4.2.

10.2.1 Funds Held in Trust. The assessments collected by the Association shall be held by the Association for and on behalf of each Owner and shall be used solely as set forth in Section 10.1. The assessments are the property of the Association and are not refundable to Owners or Lots. Upon the sale or transfer of any Lot, the Owner's interest in such funds shall be deemed automatically transferred to the successor in interest to such Owner.

10.2.2 Offsets. No offsets against any assessment shall be permitted for any reason, including, without limitation, any claim that the Association is not properly discharging its duties.

10.2.3 Right to Profits. Association profits, if any, shall be the property of the Association and shall be contributed to the Current Operating Account.

10.3 Basis of Assessment; Commencement of Assessments. Assessments for reserves shall commence for a Lot when a Lot is sold from the Declarant to a party other than a successor Declarant but can be accrued if the Lot is sold to a homebuilder for building a Home. The accrued reserves must then be paid when the homebuilder sells the completed Home to a third party. Provided, however, the reserves cannot be accrued beyond the date of the Turnover Meeting. If the Lot is not being sold to a homebuilder, then the reserves may not be accrued and must be paid when billed. Assessments for operating shall commence ninety (90) days following the date a building permit is issued for the Lot. Operation assessments may not be accrued. The amount of the annual assessment to Owners other than the Declarant shall be determined by the Declarant. The Declarant shall be exempt from paying all assessments on all Lots owned by it.

10.4 Annual Assessments. Annual assessments for each fiscal year shall be established when the Board approves the budget for that fiscal year. The initial assessment and the implementation thereof shall be determined by the Declarant and shall be prorated on a monthly basis. For prospective purposes, any portion of a month shall count as a full month. Annual assessments shall be levied on a fiscal year basis. The fiscal year shall be the calendar year unless another year is adopted by vote of the Association members. Unless otherwise specified by the Board, annual assessments shall be due and payable on the first day of each calendar year during the term of this Declaration.

10.4.1 Budgeting. Each year the Board shall prepare, approve and make available to each member a pro forma operating statement (budget) containing: (i) estimated revenue and expenses on an accrual basis; (ii) the amount of the total cash reserves of the Association currently available for replacement or major repair of the Common Area and Commonly Maintained Property and for contingencies; (iii) an itemized estimate for the remaining life of, and the methods of funding to defray repair, replacement or additions to major components of such improvements as provided in Section 10.7.2; and (iv) a general statement setting forth the procedures used by the Board in the calculation and establishment of reserves to defray the costs of repair, replacement or additions to major components of the Common Area and the Commonly Maintained Property. Notwithstanding that budgeting shall be done on an accrual basis, the Association's books shall be kept on a cash basis and the Association shall be a cash basis taxpayer, unless applicable governmental regulations require otherwise. For the first fiscal year, the budget

shall be approved by the Board no later than the date on which annual assessments are scheduled to commence. Thereafter, the Board shall annually prepare and approve the budget and distribute a copy or summary thereof to each member, together with written notice of the amount of the annual assessments to be levied against the Owner's Lot, within thirty (30) days after adoption of such budget.

10.4.2 Allocation of Assessments. The total amount in the budget shall be charged equally against all Lots, which are subject to assessment as provided in Section 10.3. Declarant shall be exempt from paying the operation portion of the assessment.

10.4.3 Nonwaiver of Assessments. If before the expiration of any fiscal year the Association fails to fix annual assessments for the next fiscal year, the annual assessments established for the preceding year shall continue until a new annual assessment is fixed.

10.4.4 Special Assessments. The Board and/or the Owners shall have the power to levy special assessments against an Owner or all Owners in the following manner for the following purposes:

10.4.4.1 Correct Deficit. To correct a deficit in the operating budget, by vote of a majority of the Board.

10.4.4.2 Special Obligations of an Owner. To collect amounts due to the Association from an Owner for breach of the Owner's obligations under this Declaration, the Bylaws, or the Rules and Regulations, by vote of a majority of the Board.

10.4.4.3 Repairs. To collect additional amounts necessary to make repairs or renovations to the Common Area or Commonly Maintained Property if sufficient funds are not available from the operating budget or replacement reserve accounts, by vote of a majority of the Board; or

10.4.4.4 Capital Improvements. To make capital acquisitions, additions, or improvements, by vote of at least eighty percent (80%) of all votes allocated to the Lots.

10.4.5 Working Capital. Upon the first sale of a Lot to a purchaser other than a successor Declarant, the purchaser will pay to the Association a working fund assessment equal to 1/6th of the annual assessment then applicable to the Lot. The Board of Directors may deposit these funds either in the Current Operating Account or the Reserve Account, at the discretion of the Board.

10.5 Accounts.

10.5.1 Types of Accounts. Assessments collected by the Association shall be deposited into at least two (2) separate accounts with a bank, which accounts shall be clearly designated as (i) the Current Operating Account and (ii) the Reserve Account. The Board shall deposit those portions of the assessments collected for current maintenance and operation into the Current Operating Account and shall deposit those portions of the assessments collected as

reserves for replacement and deferred maintenance of capital improvements into the Reserve Account. Withdrawal of funds for the Association's Reserve Account shall require the signatures of either two (2) Directors or one (1) Director and an officer of the Association who is not a Director. In its books and records, the Association shall account separately for operating expenses relating to the Common Area/Commonly Maintained Property and operating expenses relating to all other matters, as well as for necessary reserves relating to the Common Area/Commonly Maintained Property and necessary reserves relating to all other matters.

10.5.2 Reserve Account. Declarant shall establish a Reserve Account, in the name of the Association, which shall be kept separate from all other funds held by the Association. The Association shall pay out of the Reserve Account only those costs that are attributable to the maintenance, repair or replacement of Common Area property and Commonly Maintained Property that normally requires replacement, in whole or in part, within one (1) to thirty (30) years and not for regular or periodic maintenance and expenses. No funds collected for the Reserve Account may be used for ordinary current maintenance and operation purposes.

10.5.2.1 Calculation of Reserve Assessment; Reserve Study. The Board of Directors of the Association annually shall conduct a reserve study, or review and update an existing study, of the Common Area and Commonly Maintained Property to determine the reserve account requirements. A reserve account shall be established for those items of the Common Area and Commonly Maintained Property all or part of which will normally require replacement in more than three and less than 30 years, and for the maintenance, repair or replacement of other items as may be required under the Declaration or Bylaws or that the Board of Directors, in its discretion, may deem appropriate. The reserve account need not include items that could reasonably be funded from operating assessments. The reserve study shall include:

- (a) Identification of all items for which reserves are required to be established.
- (b) The estimated remaining useful life of each item as of the date of the reserve study.
- (c) The estimated cost of maintenance, repair, or replacement of each item at the end of its useful life; and
- (d) A 30-year plan with regular and adequate contributions, adjusted by estimated inflation and interest earned on reserves, to meet the maintenance, repair, and replacement schedule.

The reserve account assessment shall be allocated pursuant to Section 10.4.2.

10.5.2.2 Loan from Reserve Account. After the Turnover Meeting described in Section 8.2, the Board may borrow funds from the Reserve Account to meet high seasonal demands on the Association's regular operating fund or to meet unexpected increases in expenses. Funds borrowed must be repaid later from assessments if the Board has adopted a resolution, which may be an annual continuing resolution, authorizing the borrowing of funds. Not later than the adoption of the budget for the following year, the Board shall adopt by resolution a written payment plan providing for repayment within a reasonable period.

10.5.2.3 Investment of Reserve Account. Nothing in this Section 10.5.2 prohibits the prudent investment of Reserve Account funds, subject to any constraints imposed by the Planned Community Act, the Board, the Bylaws or the Rules and Regulations.

10.5.2.4 Refunds of Assessments. Assessments paid into the Reserve Account are the property of the Association and are not refundable to sellers or Owners of Lots. Sellers or Owners of Lots may treat their outstanding share of the Reserve Account's balance as a separate item in the sales contract providing for the conveyance of their Lot.

10.5.3 Current Operating Account. All costs other than those to be paid from the Reserve Account pursuant to Section 10.5.2 may be paid from the Current Operating Account.

10.6 Default in Payment of Assessments; Enforcement of Liens.

10.6.1 Personal Obligation. All assessments properly imposed under this Declaration or the Bylaws shall be the joint and several personal obligations of all Owners of the Lot to which such assessment pertains. In a voluntary conveyance (that is, one other than through foreclosure or a deed in lieu of foreclosure), the grantees shall be jointly and severally liable with the grantors for all Association assessments imposed through the recording date of the instrument effecting the conveyance. A suit for a money judgment may be initiated by the Association to recover such assessments without either waiving or foreclosing the Association's lien.

10.6.2 Association Lien. The Association shall have a lien against each Lot for any assessment (of any type provided for by this Declaration or the Bylaws) or installment thereof that is delinquent. The Association's lien shall accumulate all future assessments or installments, reimbursement assessments, interest, late fees, penalties, fines, attorneys' fees (whether or not suit or action is instituted), actual administrative costs, and other appropriate costs properly chargeable to an Owner by the Association, until such amounts are fully paid. Recording of the Declaration constitutes record notice and perfection of the lien. Said lien may be foreclosed at any time pursuant to the Planned Community Act. The Association shall record a notice of a claim for assessments and other charges in the deed records of Clackamas County, Oregon, before any suit to foreclose may be filed. The lien of the Association shall be superior to all other liens and encumbrances except property taxes and assessments, any first mortgage, deed of trust or land sale contract recorded before the Association's notice of lien.

10.6.3 Interest; Fines; Late Fees; Penalties. The Board, in its reasonable discretion, may from time to time adopt resolutions to set the rate of interest and to impose late fees, fines and penalties on delinquent assessments or for violations of the provisions of this Declaration, the Bylaws, Architectural Standards and the Rules and Regulations adopted by the Board or the ARC. The adoption of such impositions shall be communicated to all Owners in writing not less than thirty (30) days before the effective date by a notice mailed to the assessment billing address of such Owners. Such impositions shall be considered assessments that are lienable and collectible in the same manner as any other assessments; provided, however, that fines or penalties for violation of this Declaration, the Bylaws or any rule and regulation, other than late fees, fines or interest arising from an Owner's failure to pay regular, or special Assessments may not be imposed against an Owner or such Owner's Lot until such Owner is given an opportunity for a hearing as elsewhere provided herein.

10.6.4 Association's Right to Rents; Receiver. In any foreclosure suit by the Association with respect to such lien, the Association shall be entitled to collect reasonable rent from the defaulting Owner for the use of such Owner's Lot or shall be entitled to the appointment of a receiver.

ARTICLE 11 **GENERAL PROVISIONS**

11.1 Records. The Board shall preserve and maintain minutes of the meetings of the Association, the Board, and any committees. The Board also shall keep detailed and accurate financial records, including individual assessment accounts of Owners, the balance sheet, and income and expense statements. Individual assessment accounts shall designate the name and address of the Owner or Owners of the Lot, the amount of each assessment as it becomes due, the amounts paid upon the account, and the balance due on the assessments. The minutes of the Association, the Board and Board committees, and the Association's financial records shall be maintained in the state of Oregon and reasonably available for review and copying by the Owners. A reasonable charge may be imposed by the Association for providing copies.

11.2 Enforcement; Attorneys' Fees. The Association and the Owners and any mortgagee holding an interest on a Lot shall have the right but not the obligation to enforce all of the covenants, conditions, restrictions, reservations, easements, liens and charges now or hereinafter imposed by any of the provisions of this Declaration as may appertain specifically to such parties or Owners by any proceeding at law or in equity. Failure by either the Association or by any Owner or mortgagee to enforce any covenant, condition or restriction herein contained shall in no event be deemed a waiver of their right to do so thereafter. In the event suit or action is commenced to enforce the terms and provisions of this Declaration (including without limitations, for the collection of assessments), the prevailing party shall be entitled to its actual administrative costs incurred because of a matter or event which is the subject of the suit or action, attorneys' fees and costs in such suit or action to be fixed by the trial court, and in the event of an appeal, the cost of the appeal, together with reasonable attorneys' fees, to be set by the appellate court. In addition, thereto, the Association shall be entitled to its reasonable attorneys' fees and costs incurred in any enforcement activity or to collect delinquent assessments, together with the Association's actual administrative costs, whether or not suit or action is filed.

11.3 Construction Defect Claim Procedure. No litigation shall be commenced against the Declarant (including any successor Declarant), contractor or builder of the Home or any Owner of a Lot in respect to any alleged defect in a Home or on any Common Area except in compliance with the process set forth in ORS 701.560-701.595 and ORS 701.605.

11.4 Severability. Invalidation of any one of these covenants, conditions or restrictions by judgment or court order shall not affect the other provisions hereof and the same shall remain in full force and effect.

11.5 Duration. The covenants, conditions and restrictions of this Declaration shall run with and bind the land for a term of thirty-five (35) years from the date of this Declaration being recorded, after which time they shall be automatically extended for successive periods of ten (10) years, unless rescinded by a vote of at least ninety percent (90%) of the Owners and ninety percent

(90%) of the first mortgagees; provided, however, that amendments that do not constitute rescission of the planned community may be adopted as provided in Section 11.6

11.6 Amendment. Except as otherwise provided in Section 11.5 or ORS 94.590, and the restrictions set forth elsewhere herein, this Declaration may be amended at any time by an instrument approved by not less than seventy-five percent (75%) of the total votes of each class of members that are eligible to vote. Any amendment must be executed, recorded and certified as provided by law; provided, however, that no amendment of this Declaration shall effect an amendment of the Bylaws or Articles without compliance with the provisions of such documents, and the Oregon Nonprofit Corporation Act and that no amendment affecting the general plan of development or any other right of Declarant herein contained may be effected without the express written consent of Declarant or its successors and assigns, including, without limitation, amendment of this Section 11.6.

11.7 Release of Right of Control. Declarant may give up its right of control in writing at any time by notice to the Association.

11.8 Unilateral Amendment by Declarant. In addition to all other special rights of Declarant provided in this Declaration, Declarant may amend this Declaration in order to comply with the requirements of the Federal Housing Administration of the United States, the Federal National Mortgage Association, the Government National Mortgage Association, the Federal Home Mortgage Loan Corporation, any department, bureau, board, commission or agency of the United States or the State of Oregon, or any other state in which the Lots are marketed and sold, or any corporation wholly owned, directly or indirectly, by the United States or the State of Oregon, or such other state, the approval of which entity is required in order for it to insure, guarantee or provide financing in connection with development of the Property and sale of Lots. Prior to the Turnover Meeting, no such amendment shall require notice to or approval by any Class A member.

11.9 Resolution of Document Conflicts. In the event of a conflict among any of the provisions in the documents governing Frog Pond Crossing, such conflict shall be resolved by looking to the following documents in the order shown below:

- (a) Declaration;
- (b) Articles;
- (c) Bylaws; and
- (d) Rules and Regulations.

IN WITNESS WHEREOF, Declarant has executed this instrument this _____ day of _____, 20____.

VENTURE PROPERTIES, INC.,
an Oregon corporation

By: _____

Its: _____

STATE OF OREGON)
) ss. _____, 20____
County of _____)

Personally appeared before me the above-named _____, who, being duly sworn, did say that she is the _____ of VENTURE PROPERTIES, INC., and that said instrument was signed on behalf of said company by authority of its members; and he acknowledged said instrument to be its voluntary act and deed.

Notary Public for Oregon

AFTER RECORDING RETURN TO:

Venture Properties, Inc.
4230 Galewood Street, Suite 100
Lake Oswego, OR 97035

**BYLAWS OF
FROG POND CROSSING HOME OWNERS ASSOCIATION**

ARTICLE 1

PLAN OF LOT OWNERSHIP; DEFINITIONS

1.1 Bylaws Applicability. These Bylaws apply to the Lots and the Common Area in Frog Pond Crossing, a planned community in the City of Wilsonville, Clackamas County, Oregon, that have been subjected to the Declaration of Covenants, Conditions and Restrictions for Frog Pond Crossing (the "Declaration"), as well as to the Frog Pond Crossing Home Owners Association (the "Association") and the entire management structure thereof.

1.2 Lots; Property. The Lots and the Common Area may be collectively referred to in these Bylaws as the "Property" or "Project" and the Lots individually as a "Lot" or collectively as the "Lots."

1.3 Personal Application. All present or future Owners, tenants, Occupants, and their employees, and any other person that might occupy any portion of the Property in any manner, shall be subject to the provisions set forth in these Bylaws. The acquisition, rental, or occupancy of any of the Lots shall constitute acceptance and ratification of these Bylaws and agreement to comply with all the provisions hereof.

1.4 Definitions. Capitalized terms used but not defined herein shall have meanings attributed to them in Article 1 of the Declaration.

1.5 Oregon Planned Community Act. The Property, all Lots and Owners thereof, the Association and all Members thereof, shall be subject to the Oregon Planned Community Act, ORS 94.550 et seq. (the "PCA").

ARTICLE 2

ASSOCIATION MEMBERSHIP, VOTING, MAJORITY OF OWNERS, QUORUM, PROXIES

2.1 Membership in the Association. Upon recordation of a conveyance or contract to convey a Lot, the grantee or purchaser named in such conveyance or contract shall automatically be and shall remain a Member of the Association until such time as such person's ownership ceases for any reason. For all purposes of the Declaration and the administration of the Property, Lot ownership shall be determined from the records maintained by the Association. The record shall be established by the Owner filing with the Association a copy of the deed to or land sale contract for such Owner's Lot, to which shall be affixed the certificate of the recording officer of the County of Clackamas, Oregon, showing the date and place of recording of such deed or contract. No person shall be recognized as an Owner unless a copy of the deed or contract has been filed with the Association as provided above showing such Owner to be the current Owner or contract purchaser of a Lot. Notwithstanding the foregoing, Declarant shall be the Owner of all previously unsold Lots, although no deed or land sale contract, with respect to such Lots, has been filed with the Association.

2.2 Voting Rights. The Association shall have two (2) classes of voting Members:

2.2.1 Class A. Class A Members shall be all Owners of Lots other than Declarant, and each Class A Member shall be entitled to one (1) vote for each Lot owned with respect to all matters upon which Owners are entitled to vote.

2.2.2 Class B. The Class B Member shall be Declarant, its successors and assigns. The Class B Member shall have three (3) votes for each Lot owned; provided, however, that Class B membership shall cease on the Termination Date, as defined in Section 3.3. After termination of Class B membership, each Owner (including Declarant) shall be entitled to one (1) vote for each Lot owned with respect to all matters upon which Owners are entitled to vote, and the total number of votes shall equal the total number of Lots subjected to these Bylaws.

When more than one (1) person or entity owns a Lot, the vote for such Lot may be cast as they shall determine, but in no event shall fractional voting be allowed. Fractionalized or split votes shall be disregarded, except for purposes of determining a quorum.

2.3 Majority of Owners. As used in these Bylaws, the term "majority" shall mean those Owners holding over fifty percent (50%) of the voting rights allocated to the Owners in accordance with the Declaration and Section 2.2 above. "Majority of Owners present" shall mean Owners holding over fifty percent (50%) of the votes present at any legal meeting.

2.4 Quorum. Except as otherwise provided in these Bylaws, the presence in person or by proxy of Owners holding twenty percent (20%) or more of the outstanding votes in the Association, as defined in Section 2.2 of this Article, shall constitute a quorum. There is no quorum requirement for a statutory turnover meeting from the Declarant to Owners.

2.5 Voting; Proxies. Owners may cast votes in person, by written ballot, or by proxy. Proxies must be filed with the Secretary of the Association ("Secretary") before or during the appointed meeting. A proxy shall expire one (1) year after the date it was signed unless a shorter period is specified in the proxy. The proxies may require the holder to cast a vote for or against any special proposal set out in the notice calling the meeting. Unless withdrawn, a proxy given to another person to vote at a specific meeting shall also be valid at an adjourned meeting called under the provisions of Section 3.8. Proxies and ballots must be retained by the Association for one (1) year from the date of the determination of the vote, except that proxies and ballots relating to an amendment must be retained by the Association for one (1) year from the date the amendment is effective.

2.6 Authority to Vote. All Owners, including those who have leased their Lot to a third party, shall be entitled to vote. An Owner's right to vote may not be revoked. A purchaser under a land sale contract entitled to immediate possession of the Lot shall be deemed the Owner thereof, unless otherwise provided in such contact.

2.7 Fiduciaries and Joint Owners. An attorney-in-fact, executor, administrator, guardian, conservator or trustee may vote, in person or by proxy, at any meeting of the Association with respect to any Lot owned or held by such person in such capacity, whether or not the same shall have been transferred to such person's name, provided that such person has satisfied the Secretary that such person is the attorney-in-fact, executor, administrator, guardian, conservator

or trustee holding such Lot in such capacity. Whenever any Lot is owned by two (2) or more persons jointly according to the records of the Association, the vote of such Lot may be exercised by any one of the Owners then present, in the absence of protest by a co-owner. In the event of such protest, no one co-owner shall be entitled to vote without the approval of all co-owners. In the event of disagreement among the co-owners, the vote of such Lot shall be disregarded for all purposes, except for determining whether a quorum is present.

ARTICLE 3 **ADMINISTRATION**

3.1 Association Responsibilities. The Owners shall constitute the Members of the Association. Except as otherwise provided in the Declaration or these Bylaws, decisions and resolutions of the Association shall require approval by a majority of the Owners present at any legal meeting. A legal meeting is one duly called pursuant to these Bylaws at which a quorum is present, in person or by proxy at a formal gathering or, if a vote is taken by written ballots, when ballots are returned representing more than twenty percent (20%) of the vote, unless a larger vote is required to approve a ballot item, in which case the quorum requirements shall be the number of votes required to approve the proposal.

3.2 Place of Meetings. Formal meetings of the Association shall be held at suitable places convenient to the Owners as may be designated by the Board of Directors of the Association (the "Board").

3.3 Turnover Meeting. Declarant shall call a meeting for the purpose of turning over administrative control of the Association from Declarant to the Class A members within sixty (60) days after of the earlier of the following dates:

3.3.1 Latest Date. When one hundred percent (100%) of the lots within the Association are sold to a party other than a successor Declarant; or

3.3.2 Optional Turnover. At such time as Declarant has elected in writing to terminate Class B membership.

Declarant shall give notice of the Turnover Meeting to each Owner as provided in these Bylaws. If Declarant does not call the Turnover Meeting within sixty (60) days as required under this Section, the transitional advisory committee or any Owner may do so.

At the Turnover Meeting, Declarant shall relinquish control of the administration of the Association and the Owners shall assume such control and shall elect the Board in accordance with the provisions of Article 4 of these Bylaws and change the registered agent of the Association with the Oregon Secretary of State. Additionally, Declarant shall deliver to the Association all business and financial records, together with all Association bank accounts, funds and other assets as required by ORS 94.616. The turnover meeting may not be conducted by written ballot.

3.4 Transitional Advisory Committee. Declarant shall form a transitional advisory committee (the "Committee") to provide for the transition of administrative control of the Association from Declarant to the Class A Members. Within sixty (60) days after Declarant has conveyed fifty percent (50%) or more of Lots in the Project to Owners other than a successor

declarant, Declarant shall call a meeting of Owners for the purpose of selecting the Committee, which shall consist of three (3) Members. The Class A Members shall, by majority vote, elect two (2) Members, and Declarant shall elect one (1) Member.

The Committee's function shall be facilitating the transfer of control of the administration of the Association from Declarant to the Owners. The Committee shall have access to the information, documents and records that Declarant must turn over to the Owners under the PCA and this Article 3.

Declarant shall give notice of the meeting required under this Section 3.4 to each Owner at least seven (7), but not more than fifty (50), days prior to the meeting. The notice shall state the purpose of the meeting and the time and place where it is to be held. If Declarant does not call such meeting within the time specified, an Owner may call such meeting. If the Owners, other than Declarant, do not select Members for the Committee under this Section 3.4, Declarant shall have no further responsibility to form the Committee.

3.5 Annual Meetings. The Board, by a Board action, shall cause the first annual meeting of the Association to be held during the calendar year following the calendar year in which the Turnover Meeting is held. The Board, at its discretion, from time to time, may change the meeting date, provided that the meeting is held annually. At such meetings, the Owners shall elect new members of the Board in accordance with the requirements of Section 4.7 of these Bylaws to replace those Directors whose terms have expired. The Owners also may transact such other business of the Association as may properly come before them. Annual meetings of the Association may not be conducted by written ballot.

3.6 Special Meetings. The President shall call a special meeting of the Owners if so directed by a resolution of the Board or a petition, presented to the Secretary and signed by twenty percent (20%) or more of the Owners. All meetings called because of petition of Owners shall be held at a formal gathering, and not by written ballot, notice of which shall be sent within thirty (30) days after the Secretary's receipt of the petition. The notice of any special meeting shall state the time and place of such meeting and the purpose thereof. No business other than that stated in such notice shall be transacted at a special meeting unless by consent of all the Owners of the Lots or as otherwise set out in these Bylaws.

3.7 Notice of Meetings. The Secretary shall mail by first class mail, hand deliver, or deliver via electronic communication, a notice of each annual and special meeting, stating the purpose thereof and the time and place where such meeting is to be held, to each Owner of record at least ten (10) but not more than fifty (50) days before such meeting or the date on which ballots for a ballot meeting are required to be returned. The Board of Directors may propose that the Owners take an action by written ballot without a meeting, pursuant to the provisions of the PCA and the Oregon Nonprofit Corporation Act. Such notices shall be mailed to the Owner's mailing or email address last given to the Secretary in writing by the Owner or such Owner's vendee. If Lot ownership is split or the Lot has been sold on a contract, notice shall be sent to a single address, of which the Secretary has been notified in writing by such parties. If no address has been given to the Secretary in writing, then mailing to the Lot shall be sufficient. The mailing or emailing of a notice in the manner provided in this Section shall be considered notice served. Provided

however, an owner may decline to receive notices or ballots via electronic communication by written notice to the Secretary.

3.8 Adjourned Meetings. If any gathering of Owners is not a legal meeting because a quorum has not attended, the Owners who are present, either in person or by proxy, may adjourn the meeting to a time not less than forty-eight (48) hours or more than twenty (20) days from the time of the original meeting. The adjournment provisions of this Section do not apply to actions proposed to be taken by written ballot.

3.9 Ballot Meetings. Unless prohibited or limited by the Articles of Incorporation of the Association, any action that may be taken at any annual or special meeting of the Owners may be taken without a meeting if the Association delivers a written ballot to every Owner entitled to vote on the matter as provided in ORS 94.647. Provided, however, action by written ballot may not substitute for the turnover meeting, annual meeting, meeting to remove a director or special meeting called at the request of the Owners. Such ballot shall set forth each proposed action and provide an opportunity to vote for or against each proposed action. A proposed action shall be deemed to be approved by written ballot when the number of votes cast by ballot equals or exceeds any quorum required to be present at a meeting authorizing the action, and the number of approvals equals or exceeds the number of votes that would be required to approve the matter at a meeting at which the total number of votes cast was the same as the number of votes cast by ballot. The Board must provide Owners with at least ten (10) days' notice as required by ORS 94.647 before written ballots are mailed or otherwise delivered. If, at least three (3) days before written ballots are scheduled to be mailed or otherwise distributed, at least ten percent (10%) of the Owners petition the Board requesting secrecy procedures, a written ballot must be accompanied by a secrecy envelope, a return identification envelope to be signed by the Owner and instructions for making and returning the ballot. The Board of Directors may extend the date for counting the ballots of a ballot meeting, in one or more extensions, for up to ninety (90) days after the originally scheduled ballot return date if a quorum of ballots has not been returned and/or for matters on which a certain percentage approval is required and that vote has not been received nor have sufficient votes in opposition been received to negate such approval. Provided, however, if a secret ballot is required, secrecy ballots may not be examined or counted prior to the date certain specified in the notice or any extension thereof.

3.10 Order of Business. The order of business at all annual meetings shall be as follows:

- Roll call;
- Proof of notice of meeting or waiver of notice;
- Reading of minutes of the preceding meeting;
- Reports of officers;
- Reports of committees;
- Election of inspectors of election;
- Election of Directors;
- Unfinished business;
- New business; and
- Adjournment.

ARTICLE 4
BOARD OF DIRECTORS

4.1 Number and Qualification. The Board shall be composed of three (3) persons, all of whom must be an Owner or a co-owner of a Lot; provided, however, that if a Lot is owned by more than one (1) Owner, only one (1) co-owner of that Lot may serve on the Board of Directors at any one time. An officer or employee of a corporation, the trustee of a trust, the personal representative of an estate, or an employee of a trust or estate may serve on the Board if the corporation, trust or estate owns a Lot.

4.2 Powers and Duties. The Board shall have the powers and duties necessary for the administration of the affairs of the Association and may do all such acts and things as are not by law or by these Bylaws directed to be done by the Owners.

4.3 Other Duties. In addition to duties imposed by these Bylaws or by resolutions of the Association, the Board shall have authority to carry out and be responsible for the following matters:

4.3.1 Upkeep of Common Area and Commonly Maintained Property. Care, upkeep and supervision of the Common Area and the Commonly Maintained Property.

4.3.2 Reserves. Establishment and maintenance of replacement Reserve Accounts which the Board deems prudent for replacement of Common Area improvements or facilities and the Commonly Maintained Property.

4.3.3 Assessment Collection. Designation and collection of assessments from the Owners, in accordance with these Bylaws and the Declaration.

4.3.4 Budget; Voucher System. Establishment of a budget and payment of all common expenses of the Association and institution and maintenance of a voucher system for such payment, which shall require a sufficient number of signatories thereon as may be reasonably necessary to prevent any misuse of Association funds, in accordance with these Bylaws and the Declaration.

4.3.5 Insurance. Procurement and maintenance of insurance policies and payment of premiums therefor out of the common expense funds, as more specifically provided in Article 8 of these Bylaws.

4.3.6 Personnel. Designation and dismissal of the personnel necessary for the maintenance and operation of the Project.

4.3.7 Financial Statements. Causing the preparation and distribution of annual financial statements of the Association to each of the Owners, as more specifically provided in the Declaration.

4.3.8 Rules. Adoption and amendment of administrative Rules and Regulations governing the details of operation and use of the Common Area and administration of the Association, including a fine schedule for violations of these Bylaws, the Declaration or any rules

or regulations promulgated thereunder. Provided, however, that any such Rules and Regulations shall always be subject to rescission or amendment by the Association upon a majority vote of Owners present at any properly called meeting.

4.3.9 Copies of Documents; Bank Accounts. Causing the Association to comply with ORS 94.670 relating to maintenance within the State of Oregon of documents delivered to the Association by the Declarant, depositing all assessments in a separate federally insured account in the name of the Association, payment of all expenses of the Association from the Association's bank account, and maintenance and distribution of financial statements and to maintain copies suitable for duplication of the following: the Declaration, the Articles of Incorporation, the Bylaws, the Association rules and regulations and any amendments thereto, the most recent annual financial statement, and the current operating budget of the Association. Further, the Board of Directors shall cause to be maintained and kept current the information required to enable the Association to comply with ORS 94.670.

4.3.10 Tax Returns. Causing the Association to file the necessary tax returns of the Association.

4.3.11 Mailing Address. Establishing and maintaining a current mailing address for the Association.

4.3.12 Professional Services. Employment of legal, accounting, and other personnel or consultants for reasonable compensation to perform such services as may be required for the proper administration of the Association and preparing and filing the required income tax returns or forms.

4.4 Limited Authority. The Board shall not take any of the following actions, except with the vote or written assent of a majority of the voting power of the Owners other than Declarant:

4.4.1 Third Party Contracts. Enter into a contract with a third party wherein the third person will furnish goods or services for the Common Area, the Commonly Maintained Property, or the Association for a term longer than one (1) year with the following exceptions:

(a) Management contract, the provisions of which have been approved by the Federal Housing Administration, U.S. Housing and Urban Development or Veterans Administration.

(b) A contract with a public utility company in the City of Wilsonville or Clackamas County, or a service contract if the rates charged for the materials or services are regulated by the Oregon Public Utilities Commission; provided, however, that the term of the contract shall not exceed the shortest term for which the supplier will contract at the regulated rate.

(c) A prepaid casualty and/or liability insurance policy the term of which does not exceed three (3) years, provided that the policy permits short-rate cancellation by the insured.

4.4.2 Capital Expenditures. Incur aggregate expenditures for capital improvements (as opposed to maintenance, repair and replacement costs) to the Common Area, the Commonly Maintained Property, during any fiscal year in excess of five percent (5%) of the budgeted gross expenses of the Association for that fiscal year.

4.4.3 Compensating Board Members. Pay compensation to members of the Board or officers of the Association for services performed in the conduct of the Association's business; provided, however, that the Board may cause a member or officer to be reimbursed for expenses incurred in carrying on the business of the Association.

4.5 Management Agent. The Board may employ a management agent, to be compensated in an amount established by the Board, to perform such duties and services as the Board shall authorize, including, but not limited to, the duties listed in Section 4.3 of these Bylaws. Any such management contract must be cancelable without penalty upon thirty (30) days' written notice. Any management contract entered into by the Declarant before the Turnover Meeting may be canceled by the Board of Directors elected at the Turnover Meeting upon thirty (30) days' written notice given not later than sixty (60) days after the turnover meeting.

4.6 Interim Board and Officers. Declarant hereby reserves administrative control of the Association until the Turnover Meeting. Declarant, in its sole discretion, may appoint and remove members of the Board and officers of the Association whose terms of service shall end on or before the date of the Turnover Meeting. However, at the Turnover Meeting, at least one (1) Director shall be elected by Owners other than Declarant, even if Declarant otherwise has voting power to elect all three (3) Directors.

4.7 Election and Term of Office. At the Turnover Meeting of the Association, the term of office of two (2) Directors shall be fixed for two (2) years. The term of office of one (1) Directors shall be fixed at one (1) year. Should the number of Directors serving on the Board be increased, the same sequential election terms shall apply as nearly as is practicable. Upon expiration of the initial term of office of each respective Director, such Director's successor shall be elected to serve a term of two (2) years. The Directors shall hold office until their successors have been elected and hold their first meeting. At the Turnover Meeting, upon agreement by vote of the Owners, the Owners may elect Directors by using a ballot that permits each Owner to vote for three (3) nominees. In such event, the two (2) nominees receiving the highest number of votes shall be the two (2) year Directors and the nominee receiving the next highest number of votes shall be the one (1) year Director.

4.8 Vacancies. Vacancies on the Board caused by any reason other than the removal of a Director by a vote of the Association shall be filled for the balance of the term of each directorship by vote of a majority of the remaining Directors, even though they may constitute less than a quorum. Each person so elected shall be a Director until a successor is elected upon expiration of the term for which such person was elected by the other Directors to serve.

4.9 Removal of Directors. At any legal annual or special meeting at which removal of a Director is on the agenda (not including actions proposed to be taken by written ballot without a meeting), any one (1) or more of the Directors may be removed with or without cause, by a majority vote of the total voting power of the Owners and a successor may be then and there elected

to fill the vacancy thus created; provided, however, that the notice of meeting shall specifically indicate that the removal of one (1) or more named Directors is an agenda item for such meeting. The owners must vote on removal of each Director whose removal is proposed as a separate question. Any Director whose removal has been proposed by the Owners shall be given an opportunity to be heard at such meeting.

4.10 Organizational Meeting. The first meeting of a newly elected Board shall be held within ten (10) days of election at such place as shall be fixed by the Directors at the Association meeting at which such Directors were elected, and no notice shall be necessary to the newly elected Directors in order to hold such meeting legally, providing a majority of the newly elected Directors are present.

4.11 Regular Meetings. Regular meetings of the Board may be held at such time and place as shall be determined, from time to time, by a majority of the Directors. Notice of regular meetings of the Board may be called by the President on at least three (3) days' notice to each Director, given personally or by mail, telephone, e-mail or facsimile, which notice shall state the time, place (as hereinabove provided) and purpose of the meeting.

4.12 Special Meetings. Special meetings of the Board may be called by the President or Secretary or on the written request of at least two (2) Directors. Special meetings of the Board may be called on at least three (3) days' notice to each Director, given personally or by mail, telephone, e-mail or facsimile, which notice shall state the time, place (as hereinabove provided) and purpose of the meeting.

4.13 Waiver of Notice to Directors. Before, at or after any meeting of the Board, any Director may, in writing, waive notice of such meeting and such waiver shall be deemed equivalent to the giving of such notice. Attendance by a Director at any meeting of the Board shall be a waiver of notice by such Director of the time and place thereof. If all the Directors are present at any meeting of the Board, no notice to Directors shall be required and any business may be transacted at such meeting.

4.14 Board of Directors' Quorum. At all meetings of the Board, a majority of the existing Directors shall constitute a quorum for the transaction of business, and the acts of the majority of the Directors shall be the acts of the Board. If quorum requirements are not met at any meeting of the Board, the majority of those present may adjourn the meeting from time to time. At any such adjourned meeting, any business that might have been transacted at the meeting as originally called may be transacted without further notice.

4.15 Board Meetings Open to All Association Members. Except for executive sessions, all meetings of the Board shall be open to any and all Members of the Association; provided, however, that no Association Member shall have a right to participate in the Board's meetings unless such Member is also a member of the Board. The President shall have authority to exclude any Association Member who disrupts the proceedings at a meeting of the Board. At the discretion of the Board, the following matters may be done in executive sessions:

4.15.1 Consultation with legal counsel;

4.15.2 Consideration of personnel matters, including salary negotiations and employee discipline;

4.15.3 Negotiations of contracts with third parties;

4.15.4 Collection of assessments; and

4.15.5 Consideration of any other matter permitted by the PCA to be discussed in executive session.

Except in the case of an emergency, the Board shall vote in an open meeting whether to meet in executive session. If the Board votes to meet in executive session, the presiding officer of the Board shall state the general nature of the action to be considered, as precisely as possible, when and under what circumstances the deliberations can be disclosed to Owners. The statement, motion or decision to meet in executive session must be included in the minutes of the meeting. A contract or an action considered in executive session does not become effective unless the Board, following the executive session, reconvenes in open meeting and votes on the contract or action, which must be reasonably identified in the open meeting and included in the minutes.

4.16 Notice to Association Members of Board Meetings. For other than emergency meetings, notice of special Board meetings shall be mailed or delivered via electronic communication to each Owner at least seven (7) days before the meeting or at least three (3) days' notice by hand delivery to each Lot Owner's address or by facsimile transmission. The Board shall give Owners notice of regular Board meetings at the beginning of each year by first class mail or other reasonable means setting out the time and place of the regular meetings. For any changed time or place, the notice requirements for special meetings shall apply.

4.17 Emergency Meetings. In the event of an emergency, Board of Directors meetings may be conducted by telephonic communication or by the use of a means of communication that allows all Board members participating to hear each other simultaneously or otherwise to be able to communicate during the meeting. No notice to either Directors or Association members shall be required for such meetings of the Board of Directors to be held for any emergency action. Provided, however, that no such meeting shall occur unless at least two-thirds (2/3rds) of the Board of Directors participate in the same and after an attempt has been made to reach each Director.

4.18 Compensation of Directors. No Director shall be compensated in any manner, except for out-of-pocket expenses, unless such compensation is approved by vote of the Owners.

ARTICLE 5 **OFFICERS**

5.1 Designation. The principal officers of the Association shall be a President, a Secretary and a Treasurer, all of whom shall be elected by the Directors. The Directors may appoint an assistant treasurer and an assistant secretary, and any such other officers as in their judgment may be necessary.

5.2 Election of Officers. The officers of the Association may be elected by the Board at the organizational meeting of each new Board or any Board meeting thereafter and shall hold office at the pleasure of the Board.

5.3 Removal of Officers. Upon an affirmative vote of a majority of the Board, any officer may be removed, either with or without cause, and such officer's successor may be elected at any regular or special meeting of the Board.

5.4 President. The President shall be the chief executive officer of the Association and shall preside at all meetings of the Association and of the Board. The President shall have all of the general powers and duties which are usually vested in the office of president of an association, including, but not limited to, the power to appoint committees from among the Owners from time to time as the President may, in the President's discretion, decide is appropriate to assist in the conduct of the affairs of the Association.

5.5 Secretary. The Secretary shall keep the minutes of all meetings of the Board and the minutes of all meetings of the Association and shall have charge of such books and papers as the Board may direct; and shall, in general, perform all the duties incident of the office of secretary.

5.6 Treasurer. The Treasurer shall have responsibility for Association funds and securities and shall be responsible for keeping full and accurate accounts of all receipts and disbursements in books belonging to the Association. The Treasurer shall be responsible for the deposit of all monies and other valuable effects in the name, and to the credit, of the Association in such depositories as may from time to time be designated by the Board.

5.7 Directors as Officers. Any Director may be an officer of the Association.

ARTICLE 6 **OBLIGATIONS OF THE OWNERS**

6.1 Assessments. All Owners are obligated to pay assessments imposed by the Association to meet all the Association's general common expenses, as more particularly set forth in the Declaration. Assessments shall be payable on a periodic basis, not more frequently than monthly, as determined by the Board. Declarant (before turnover) and the Board (after turnover) may, but shall not be required to, impose interest or a service charge for late installment payments or allow a discount for payment of the annual assessment or any installment in advance.

6.2 Investment of Reserve Account Funds. Assessments paid into Reserve Accounts shall be kept with a safe and responsible depository, shall be accounted for separately and, if invested, the obligation or security shall be fully guaranteed as to principal by the United States of America or one of its agencies. Assessments paid into the Reserve Accounts are the property of the Association and are not refundable to sellers of Lots. However, nothing contained herein shall prevent sellers of Lots from treating their outstanding allocable share of Reserve Accounts as a separate or reimbursable item in a sales agreement. No Owner shall have any individual rights in any of these reserves, although it is understood that the value of an Owner's Lot may increase in proportion to such Lot's right to receive repair, maintenance and replacement therefrom.

6.3 Initial Assessment. The amount of the initial assessment due from Lot Owners other than the Declarant shall be determined by the Declarant.

6.4 Income Tax Returns; Determination of Fiscal Year.

6.4.1 Fiscal Year. The fiscal year of the Association shall be the calendar year unless otherwise determined by the Board.

6.4.2 Tax Returns. The Board, in its sole discretion, shall determine the manner in which all necessary income tax returns are filed and of selecting any and all persons to prepare such tax returns.

6.5 Statement of Assessments.

6.5.1 The Association shall provide, within ten (10) business days of receipt of a written request from an Owner, a written statement that provides:

(a) The amount of assessments due from the Owner and unpaid at the time the request was received, including:

Regular and special assessments;
Fines and other charges;
Accrued interest; and
Late payment charges.

(b) The percentage rate at which interest accrues on assessments that are not paid when due.

(c) The percentage rate used to calculate the charges for late payment or the amount of a fixed charge for late payment.

6.5.2 The Association is not required to comply with Section 6.5.1 if the Association has commenced litigation by filing a complaint against the Owner and the litigation is pending when the statement would otherwise be due.

6.6 Default. Failure by an Owner to pay any assessment of the Association shall be a default by such Owner of such Owner's obligations pursuant to these Bylaws and the Declaration. The Association shall be entitled to the remedies set forth in the Declaration.

6.7 Maintenance and Repair.

6.7.1 Lots. Except as otherwise specifically provided in the Declaration and these Bylaws, every Owner must perform promptly all maintenance and repair work to such Owner's Lot and the exterior of the improvements thereon (which do not constitute Commonly Maintained Property) and keep the same in good repair and sanitary and neat condition.

6.7.2 Common Area and Commonly Maintained Property. The Association shall repair and maintain the Common Area and the Commonly Maintained Property, subject to the provisions of subsection 6.7.3.

6.7.3 Reimbursement of Association. An Owner shall reimburse the Association for any expenditures incurred in repairing or replacing any portion of the Common Area or of any Commonly Maintained Property that was damaged through such Owner's fault and that is not otherwise covered by insurance policies carried by the Owner or the Association for the Owner's and the Association's benefit. In such circumstances, the insurance obtained by the Owner shall be deemed to be the primary coverage. The Board of Directors shall have the unfettered discretion to refuse to make a claim on the Association's policy even though coverage may pertain. Such discretion is for the purpose of maintaining the Association's insurability and controlling the amount of the premiums for the Association's insurance. Such charge shall be collectible as a reimbursement assessment as provided in the Declaration.

6.8 Right of Entry; Easements for Maintenance.

6.8.1 Emergencies. Present and future Owners, tenants, Occupants, and any other persons that occupy any portion of the Property, by virtue of acquisition, rental, or occupancy of any of the Lots, grant to the management agent or to any other person authorized by the Board or the Association the right to enter upon such Lot in the event of an emergency originating in or threatening any Owner's Lot.

6.8.2 Maintenance Easements. Declarant grants an easement to the Association in and through any Lot and the Common Area providing access at reasonable times and with reasonable notice for purposes of maintenance, repair and replacement of the Common Area and Commonly Maintained Property. If, in performing such repair and maintenance, the Association needs to alter or damage any Lot, Commonly Maintained Property or Common Area, it may do so without providing compensation, provided that it promptly restores the Lot and/or Common Area to substantially its prior condition.

ARTICLE 7

USE AND OCCUPANCY RESTRICTIONS; RULES OF CONDUCT

In addition to the restrictions and rules of conduct set forth in the Declaration, the following shall apply:

7.1 Use of the Common Area. No Owner shall place or cause to be placed on any portion of the Common Area any trash, structure, equipment, improvement, furniture, package or object of any kind. Common Areas shall be used for no purpose other than what is customary for such areas.

7.2 Appearance of Lots. Owners shall keep their Lots and the improvements thereon in good repair, clean, and with painted, stained or other finished exteriors compatible with the Architectural Standards, the Declaration and Rules and Regulations. Provided, however, the Association shall have such obligations with respect to the Commonly Maintained Property.

7.3 Nuisances. No Owner or Occupant shall cause or permit such Owner's representatives, agents, employees, or family members to cause any nuisance or to make any use or engage in any practice on the Property that is a source of annoyance to other Owners and Occupants or that interferes with other Owners' and Occupants' peaceful possession and proper use of the Property. Owners and Occupants shall exercise extreme care about creating disturbances, making noises or using musical instruments, radios, televisions and amplifiers that may disturb other Owners and Occupants. Owners and Occupants shall keep all parts of their respective Lots in a clean and sanitary condition, free of any accumulation of rubbish, refuse or garbage and free of any fire hazard and shall not cause any accumulation of rubbish, refuse or garbage or any fire hazard on any other part of the Property. Owners and Occupants shall place all of their rubbish, refuse and garbage inside disposal containers. No Owner shall make or permit any use of such Owner's Lot or of the Common Area that will increase the cost of insurance upon the Common Area.

7.4 Improper, Offensive or Unlawful Use. No Owner or Occupant shall make any improper, offensive or unlawful use of any part of the Property. Owners and Occupants shall observe all valid laws, zoning ordinances and regulations of governmental bodies having jurisdiction over the Property. The responsibility for meeting the requirements of governmental bodies for maintenance, modification or repair of the Property shall be carried out and paid for in the same manner as the responsibility for the maintenance and repair of the Property concerned.

7.5 Additional Rules. In addition to the rules set forth in this Article 7, the Board may promulgate and amend, from time to time, Rules and Regulations concerning other use of the Property and shall furnish copies of such Rules and Regulations to any Owner or Occupant requesting such copies.

7.6 Enforcement. The Association, through its Board of Directors, shall have the power to enforce the covenants and restrictions in these Bylaws and in the Declaration. Owners shall also have the right to bring actions or suits regarding covenants and restrictions but shall have no right or power to require the Association or Board of Directors to take any enforcement action.

7.7 Fines. The Board of Directors may, after giving written notice and an opportunity to be heard, levy reasonable fines for violations of the Declaration, Bylaws and rules and regulations of the Association, provided that fines levied are based on a schedule previously adopted by Board resolution that is mailed to the mailing address of each Lot or mailed to the mailing address designated in writing by the Owner(s).

ARTICLE 8 **INSURANCE**

8.1 General. The Board shall obtain and maintain at all times insurance of the type and kind and in the amounts hereinafter provided and additional insurance for such other risks of a similar or dissimilar nature as are now or as shall be hereafter customarily covered by insurance obtained by other planned communities similar in construction and design. Such additional insurance shall be governed by this Article 8.

8.2 Types of Insurance Policies Maintained By the Association. For the benefit of the Association and the Owners, the Board shall obtain and maintain at all times, and shall pay for out of the common expense funds, the following insurance to the extent that it is available at reasonable cost:

8.2.1 Property Insurance. A policy or policies of property insurance, including, but not limited to, fire, extended coverage, vandalism and malicious mischief, for the full insurable replacement value of the Common Area to the extent such insurance is available and, if available at a reasonable cost, shall obtain building code and actual replacement cost endorsements and earthquake insurance.

8.2.2 Liability. A policy or policies insuring the Association, its Board, the Owners individually, and the manager against any liability to the public or the Owners and their invitees or tenants, incident to the ownership, supervision, control or use of the Property. Limits of liability under such insurance shall be not less than one million dollars (\$1,000,000) per occurrence for bodily injuries and property damage liability. Such limit and coverage shall be reviewed at least annually by the Board, which may increase the limit of and/or coverage, in its discretion. Said policy or policies shall be issued on a commercial General Liability form and shall provide cross liability endorsements wherein the rights of the named insured under the policy or policies shall not be prejudiced as respects his, her or their action against another named insured.

8.2.3 Workers Compensation. Workers Compensation Insurance to the extent that it is necessary to comply with any applicable laws.

8.2.4 Crime; Employee Dishonesty Insurance. The Board must obtain a fidelity, employee dishonesty and crime insurance policy(ies) which insures the Association against theft or embezzlement of Association funds.

8.2.5 Directors' and Officers' Insurance. Directors' and officers' insurance insuring the directors and officers.

8.3 Insurance Companies Authorized. All policies obtained under this Article 8 shall be written by a company licensed to do business in Oregon and holding a "Commissioner's Rating" of "B+" and a size rating of "IX," or better, by Best's Insurance Reports, or as may be otherwise acceptable to all mortgagees and Directors.

8.4 Provisions in Insurance Policies. The Board shall make every reasonable effort to secure insurance policies that will provide for the following:

8.4.1 Waiver of Subrogation. A waiver of subrogation by the insurer as to any claims against the Board, the officers, the manager, the Owners and their respective servants, agents, guests and tenants.

8.4.2 Noncancellation for Owner Conduct. A provision that the master policy on the Property cannot be canceled, invalidated or suspended on account of the conduct of any one or more individual Owners.

8.4.3 Noncancellation Without Opportunity to Cure. A provision that the master policy on the Property cannot be canceled, invalidated or suspended on account of the conduct of any officer, Board member or employee of the Board or the manager without prior demand in writing that the Board or manager cure the defect.

8.4.4 No Other Insurance Clauses. A provision that any "no other insurance" clause in the master policy exclude individual Owners' policies and not otherwise prevent such individual policies from providing coverage for damage to Homes, Lots or Common Area.

8.5 Home and Lot Insurance Maintained By Each Owner. The Association shall have no responsibility to procure or to assist Owners or Occupants in procuring property loss insurance or liability insurance other than as expressly stated in this Article 8. Owners and Occupants shall procure all other insurance coverage that they deem necessary or prudent for their protection and shall be obligated to carry property insurance with extended coverage endorsements in the amount of the replacement value of such Owners' Homes and liability insurance with minimum combined limits of \$100,000 per occurrence. Such obligation may be discharged with respect to the Attached Home Lot improvements by a sub-association created pursuant to an Additional Declaration. Insurance coverage obtained and maintained by the Board of Directors may be brought into contribution with that obtained and maintained by Owners or mortgagees only in the Board of Directors' sole and unfettered discretion.

8.6 Review of Insurance Policies. At least annually, the Board shall review all insurance carried by the Association, which review shall include a consultation with a representative of the insurance carrier writing the master policy.

8.7 Deductible Provisions. The Board of Directors may negotiate the amount of the deductible in all Association insurance policies at such limits as are reasonable and customary under the circumstances and the deductible amount may be set at different levels for different insured risks. The Board shall adopt a resolution providing the responsibility for payment of the deductible. If no such resolution has been adopted, the Association shall be responsible for the deductible.

ARTICLE 9 **AMENDMENT**

Except as otherwise provided in this Article, and the restrictions set forth elsewhere herein, these Bylaws may be amended at any time by an instrument approved by at least a majority of the total votes of each class of Members that are eligible to vote. Any amendment must be executed, recorded and certified as provided by law. Provided, however, no amendment of these Bylaws may effect an amendment of the Declaration or the Articles without compliance with the provisions of such documents and the Oregon Nonprofit Corporation Act, and no amendment deleting or affecting any right of Declarant or its successor or assignee, including, without limitation, an amendment to this Article 9, may be adopted without the prior written consent of Declarant or its successor or assignee.

ARTICLE 10
RECORDS AND AUDITS

10.1 General Records. The Board and the managing agent or manager, if any, shall preserve and maintain minutes of the meetings of the Association, the Board and any Board committees as required by ORS 94.670. The Board shall maintain a list of Owners entitled to vote at meetings of the Association. The minutes of the Association, the Board and Board committees, and the Association's financial records shall be reasonably available for review and copying by the Owners. A reasonable charge may be imposed by the Association for providing copies.

10.2 Assessment Roll. The Board and the managing agent or manager, if any, shall maintain the assessment roll in a set of accounting books in which there shall be an account for each Lot. Such account shall designate the name and address of the Owner or Owners, the amount of each assessment against the Owner, the dates on which and the amounts in which the assessment comes due, the amounts paid upon the account and the balance due on the assessments.

10.3 Payment of Vouchers. The Treasurer or management agent shall pay all expenses authorized by the Board. The Treasurer or management agent shall maintain and follow reasonable procedures to assure the accounts and proper records, and to assure that all expenditures are proper. Except in cases where an emergency exists (for example, a repair must be made immediately to prevent further damage), any voucher for non-budgeted items shall require the signature of the President; provided, however, that any withdrawal from Reserve Accounts shall require the signature of two Board members or one Board member and an officer of the Association who is not a Board member.

ARTICLE 11
COMPLIANCE WITH THE PLANNED COMMUNITY ACT; CONFLICTS

These Bylaws are intended to comply with the provisions of the PCA, the provisions of which apply to Frog Pond Crossing. In case of any conflict among the provisions of the PCA, the Articles, the Declaration, or these Bylaws, the provisions of the PCA shall control over those of the Articles and Declaration, and the provisions of the Declaration shall be control over those of the Articles and these Bylaws.

ARTICLE 12
INDEMNIFICATION OF DIRECTORS, OFFICERS, EMPLOYEES AND AGENTS

The Association shall indemnify any Director, officer, employee or agent who was or is a party or is threatened to be made a party to any threatened, pending or completed action, suit or proceeding, whether civil, criminal, administrative or investigative (other than an action by the Association) by reason of the fact that such person is or was a Director, officer, employee or agent of the Association or is or was serving at the request of the Association as a Director, officer, employee or agent of another corporation, partnership, joint venture, trust or other enterprise, against expenses (including attorneys' fees), judgments, fines and amounts paid in settlement actually and reasonably incurred by said person in connection with such suit, action or proceeding if such person acted in good faith and in a manner that such person reasonably believed to be in, or not opposed to, the best interest of the Association, and, with respect to any criminal action or

proceedings, had no reasonable cause to believe that such person's conduct was unlawful. The termination of any action, suit or proceeding by judgment, order, settlement, conviction, or with a plea of nolo contendere or its equivalent, shall not of itself create a presumption that a person did not act in good faith and in a manner that such person reasonably believed to be in, or not opposed to, the best interest of the Association, and, with respect to any criminal action or proceedings, had reasonable cause to believe that such person's conduct was unlawful. Payment under this clause may be made during the pendency of such claim, action, suit or proceeding as and when incurred, subject only to the right of the Association to reimbursement of such payment from such person, should it be proven at a later time that such person had no right to such payments. All persons who are ultimately held liable for their actions on behalf of the Association as a Director, officer, employee or agent shall have a right of contribution over and against all other Directors, officers, employees or agents and Members of the Association who participated with or benefited from the acts that created said liability.

ARTICLE 13 **ASSESSMENT COLLECTION COSTS; SUITS AND ACTIONS**

An Owner shall be obliged to pay reasonable fees and costs (including, but not limited to, attorneys' fees) and actual administrative costs incurred in connection with efforts to collect any delinquent unpaid assessments from such Owner, whether or not suit or action is filed. Assessments against Owners may include fees, late charges, fines and interest imposed by the Board, in addition to amounts owed toward operating expenses and the funding of reserves. If the Association brings against any Owner or Owners a suit or action for the collection of any amounts due pursuant to or for the enforcement of any provisions of the Declaration, the Articles or these Bylaws, such Owner or Owners, jointly and severally, shall pay, in addition to all other obligations, the costs of such suit or action, including actual administrative expenses incurred by the Association because of the matter or act which is the subject of the suit, reasonable attorneys' fees to be fixed by the trial court and, in the event of an appeal, the cost of the appeal, together with reasonable attorneys' fees in the appellate court to be fixed by such court.

ARTICLE 14 **MISCELLANEOUS**

14.1 Notices. All notices to the Association or to the Board shall be sent care of the managing agent or, if there is no managing agent, to the principal office of the Association or to such other address as the Board hereafter may designate from time to time. All notices to any Owner shall be sent to such address as may have been designated by such Owner from time to time, in writing, to the Board, or if no address has been designated, then to such Owner's Lot.

14.2 Waiver. No restriction, condition, obligation or provision contained in these Bylaws shall be deemed to have been abrogated or waived by reason of any failure to enforce the same, irrespective of the number of violations or breaches thereof that may have occurred and the number of times that the pertinent restriction, condition, obligation or provision was not enforced.

14.3 Invalidity; Number; Captions. The invalidity of any part of these Bylaws shall not impair or affect in any manner the validity, enforceability or effect of the balance of these Bylaws. As used herein, the singular shall include the plural, and the plural the singular. The

masculine and neuter shall each include the masculine, feminine and neuter, as the context requires. All captions used herein are intended solely for convenience of reference and shall in no way limit any of the provisions of these Bylaws.

ARTICLE 15
ADOPTION

It is hereby certified that these Bylaws have been adopted by Venture Properties, Inc., an Oregon corporation, Declarant of Frog Pond Crossing, and shall be recorded in the Deed Records of Clackamas County, together with the Declaration for said planned community.

DATED this _____ day of _____, 20__

VENTURE PROPERTIES, INC.
an Oregon corporation,

By: _____
Its: _____

STATE OF OREGON)
) ss. _____, 20__
County of _____)

Personally, appeared before me the above-named _____, who, being duly sworn, did say that she is the _____ of Venture Properties, Inc. and that said instrument was signed on behalf of said company by authority of its members; and he acknowledged said instrument to be its voluntary act and deed.

Notary Public for Oregon

Exhibit J: Annexation Petition and Certification

PETITION FOR ANNEXATION

We, the undersigned owner(s) of the property described in **Exhibit A** and/or elector(s) residing at the referenced location(s), hereby petition for, and give consent to, Annexation of said property to the City of Wilsonville:

NOTE: This petition may be signed by any qualified persons even though they may not know their property description or precinct number.

SIGNATURE	PRINTED NAME	I AM A: *			PROPERTY ADDRESS	PROPERTY DESCRIPTION			PRECINCT #	DATE	
		PO	RV	OV		LOT #	¼ SEC	T			R
<i>Paul C. Chaney</i>	Paul C. Chaney			X	27227 SW Stafford Rd, Wilsonville, OR 97070	100	12	3S	1W	323	4/20/21
<i>Janene P. Chaney</i>	Janene P. Chaney			X						✓	4/20/21
<i>Paul C. Chaney</i>	Paul C. Chaney			X	-	300	12	3S	1W	✓	4/20/21
<i>Janene P. Chaney</i>	Janene P. Chaney			X						✓	4/20/21
<i>Paul C. Chaney</i>	Paul C. Chaney			X	-	302	12	3S	1W	✓	4/20/21
<i>Janene P. Chaney</i>	Janene P. Chaney			X						✓	4/20/21

- * PO - Property Owner
- RV - Registered Voter
- OV - Property Owner & Registered Voter

CERTIFICATION OF PROPERTY OWNERSHIP

I hereby certify that the attached petition for annexation contains the names of the owners¹ (as shown on the last available complete assessment roll) of 100% of the land area of the territory proposed for annexation as described in the attached petition.

NAME:

[Handwritten Signature]

TITLE:

Cartographer

DEPARTMENT:

Tax Assessment

COUNTY OF:

Clackamas

DATE:

5/10/21



¹ "Owner" means the legal owner of record or, where there is a recorded a land contract which is in force, the purchaser thereunder. If there is a multiple ownership in a parcel of land each consenting owner shall be counted as a fraction to the same extent as the interest of the owner in the land bears in relation to the interest of the other owners and the same fraction shall be applied to the parcel's land mass and assessed value for purposes the consent petition. If a corporation owns land in territory proposed to be annexed, the corporation shall be considered the individual owner of that land.

31W 12D



401
5.17 Ac.
6725

300
6.42 Ac.

100
2.02 Ac.
27227

200
2.02 Ac.

See P.S. 5235

3-23

RECEIVED
CLACKAMAS
COUNTY
ASSESSOR

MAY 2021

5/10/2021

27000

27400

STAFFORD (MERIDIAN) ROAD

SEE MAP 3-9E



Exhibit K: Annexation Legal Description, Exhibit, and Certification



AKS ENGINEERING & FORESTRY, LLC
12965 SW Herman Road, Suite 100, Tualatin, OR 97062
P: (503) 563-6151 | www.aks-eng.com

AKS Job #5252

OFFICES IN: BEND, OR - KEIZER, OR - TUALATIN, OR - VANCOUVER, WA

EXHIBIT A

City Annexation Description

A tract of land, and a portion of right-of-way, located in the Northwest and Southwest One-Quarter of Section 7, Township 3 South, Range 1 East, and the Northeast and Southeast One-Quarter of Section 12, Township 3 South, Range 1 West, Willamette Meridian, Clackamas County, Oregon, and being more particularly described as follows:

Beginning at the southeast corner of Parcel II of Partition Plat 1991-043, Clackamas County Plat Records, also being on the west right-of-way line of Stafford Road (30.00 feet from centerline); thence along said west right-of-way line, North $01^{\circ}40'07''$ East 33.45 feet to the westerly extension of the north right-of-way line of Kahle Road (15.00 feet from centerline); thence along said westerly extension, South $88^{\circ}00'29''$ East 60.00 feet to the intersection of said north right-of-way line and the east right-of-way line of Stafford Road (30.00 feet from centerline); thence along said east right-of-way line, South $01^{\circ}40'07''$ West 932.66 feet to the easterly extension of the north right-of-way line of Frogpond Lane (16.50 feet from centerline) and the City of Wilsonville city limits line; thence along said easterly extension and said city limits line, North $88^{\circ}35'24''$ West 60.00 feet to the intersection of said north right-of-way line and the said west right-of-way line of Stafford Road; thence leaving said city limits line along said west right-of-way line, North $01^{\circ}40'07''$ East 241.00 feet to the northeast corner of Document Number 2015-020686, Clackamas County Deed Records; thence along the north line of said deed, North $88^{\circ}35'24''$ West 365.01 feet to the northwest corner thereof; thence along the west line of said deed, South $01^{\circ}41'37''$ West 241.00 feet to said north right-of-way line of Frogpond Lane and said city limits line; thence along said north right-of-way line and said city limits line, North $88^{\circ}35'24''$ West 142.58 feet to the southeast corner of Document Number 2018-044491, Clackamas County Deed Records; thence leaving said city limits line along the east line of said deed, North $01^{\circ}40'07''$ East 897.83 feet to the south line of said Parcel II; thence along said south line, South $88^{\circ}48'53''$ East 507.71 feet to the Point of Beginning.

The above described tract of land contains 9.27 acres, more or less.

Bearings for this description are based on State Plane Grid bearing, Oregon State Plane, North Zone 3601, NAD83(2011) Epoch: 2010.0000. Distances shown are International Foot ground values.

4/22/2021

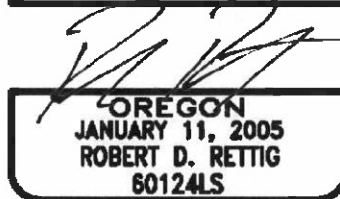

OREGON
JANUARY 11, 2005
ROBERT D. RETTIG
60124LS

RENEWS: 12/31/22

EXHIBIT B

A TRACT OF LAND, AND A PORTION OF RIGHT-OF-WAY,
 LOCATED IN THE NORTHWEST AND SOUTHWEST 1/4 OF SECTION 7,
 TOWNSHIP 3 SOUTH, RANGE 1 EAST, AND
 THE NORTHEAST AND SOUTHEAST 1/4 OF SECTION 12,
 TOWNSHIP 3 SOUTH, RANGE 1 WEST, WILLAMETTE MERIDIAN,
 CLACKAMAS COUNTY, OREGON

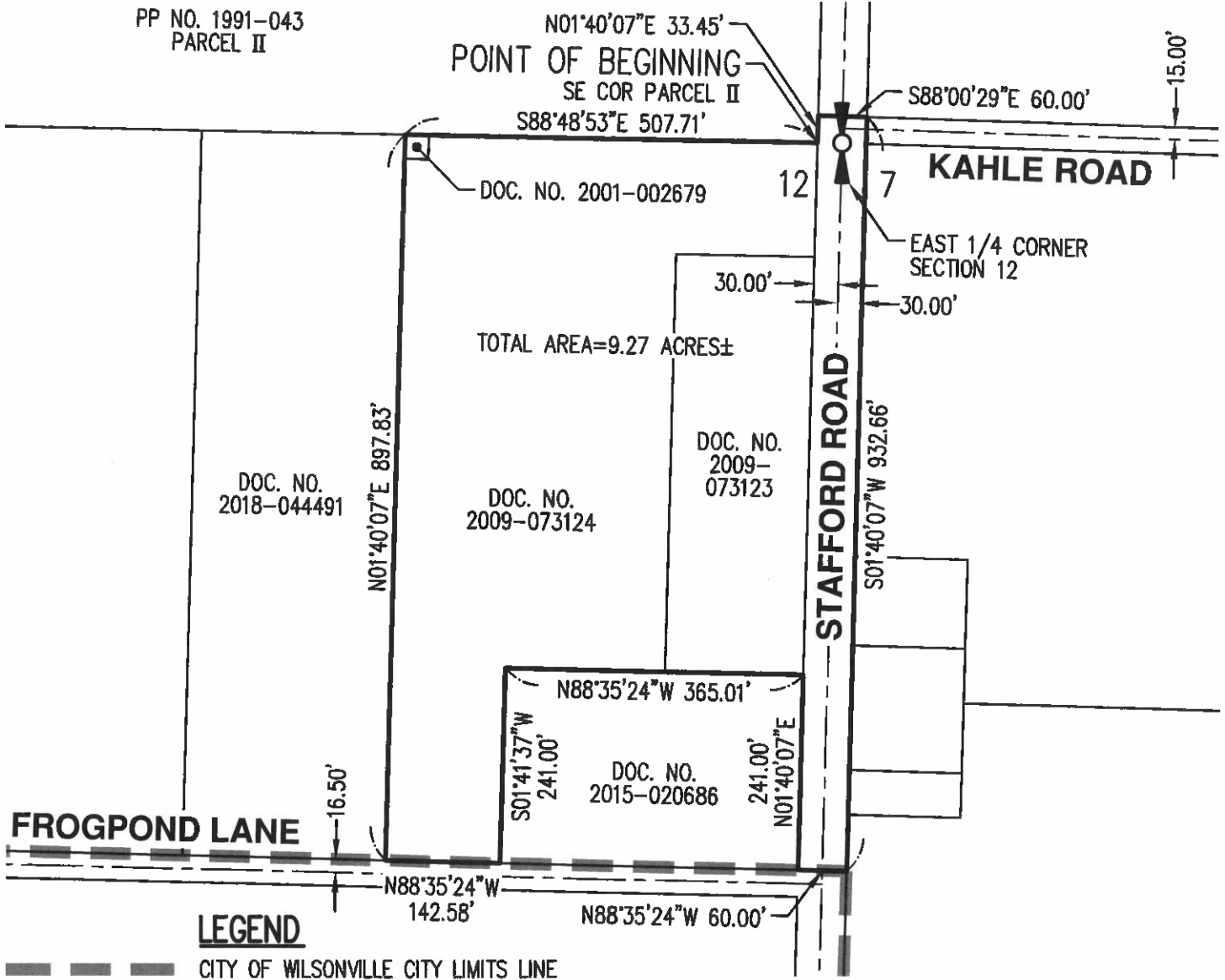

4/22/2021

REGISTERED
 PROFESSIONAL
 LAND SURVEYOR

PREPARED FOR

VENTURE PROPERTIES, INC.
 4230 SW GALEWOOD STREET, SUITE 100
 LAKE OSWEGO, OR 97035

SCALE: 1" = 200 FEET

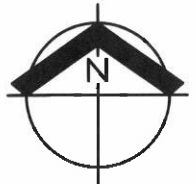
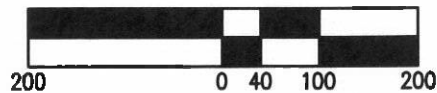

[Signature]

OREGON
 JANUARY 11, 2005
 ROBERT D. RETTIG
 60124LS

RENEWS: 12/31/22

CITY ANNEXATION MAP

AKS ENGINEERING & FORESTRY, LLC
 12965 SW HERMAN RD, STE 100
 TUALATIN, OR 97062
 503.563.6151 WWW.AKS-ENG.COM



EXHIBIT
B

DRWN: WCB
 CHKD: RDR
 AKS JOB:
 5252

CERTIFICATION OF LEGAL DESCRIPTION AND MAP

I hereby certify that the description of the property included within the attached petition (located on Assessor's Map 31W12D) has been checked by me and it is a true and exact description of the property under consideration, and the description corresponds to the attached map indicating the property under consideration.

NAME:

C. K. S.

TITLE:

Cartographer

DEPARTMENT:

Tax Assessor

COUNTY OF:

Clackamas

DATE:

5/10/21

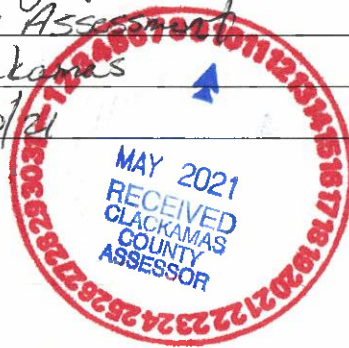

31W 12D



401
5.17 Ac.
6725

300
6.42 Ac.

400
2.02 Ac.
27227

200
2.02 Ac.

See P.S. 5235

3-23

MAY 2021
RECEIVED
CLACKAMAS
COUNTY
ASSESSOR

5/10/2021

27000

27400

STAFFORD (MERIDIAN) ROAD

ROGPOND LN.

TRANSMISSION
EASEMENT
MARCOLA SEC.

SEE MAP 3-9E



Exhibit L: **Zoning Change Legal Description and Exhibit**



EXHIBIT A

Zone Change Description

A tract of land, and a portion of right-of-way, located in the Northwest and Southwest One-Quarter of Section 7, Township 3 South, Range 1 East, and the Northeast and Southeast One-Quarter of Section 12, Township 3 South, Range 1 West, Willamette Meridian, Clackamas County, Oregon, and being more particularly described as follows:

Beginning at the southeast corner of Parcel II of Partition Plat 1991-043, Clackamas County Plat Records, also being on the west right-of-way line of Stafford Road (30.00 feet from centerline); thence along said west right-of-way line, North $01^{\circ}40'07''$ East 33.45 feet to the westerly extension of the north right-of-way line of Kahle Road (15.00 feet from centerline); thence along said westerly extension, South $88^{\circ}00'29''$ East 60.00 feet to the intersection of said north right-of-way line and the east right-of-way line of Stafford Road (30.00 feet from centerline); thence along said east right-of-way line, South $01^{\circ}40'07''$ West 932.66 feet to the easterly extension of the north right-of-way line of Frogpond Lane (16.50 feet from centerline) and the City of Wilsonville city limits line; thence along said easterly extension and said city limits line, North $88^{\circ}35'24''$ West 60.00 feet to the intersection of said north right-of-way line and the said west right-of-way line of Stafford Road; thence leaving said city limits line along said west right-of-way line, North $01^{\circ}40'07''$ East 241.00 feet to the northeast corner of Document Number 2015-020686, Clackamas County Deed Records; thence along the north line of said deed, North $88^{\circ}35'24''$ West 365.01 feet to the northwest corner thereof; thence along the west line of said deed, South $01^{\circ}41'37''$ West 241.00 feet to said north right-of-way line of Frogpond Lane and said city limits line; thence along said north right-of-way line and said city limits line, North $88^{\circ}35'24''$ West 142.58 feet to the southeast corner of Document Number 2018-044491, Clackamas County Deed Records; thence leaving said city limits line along the east line of said deed, North $01^{\circ}40'07''$ East 897.83 feet to the south line of said Parcel II; thence along said south line, South $88^{\circ}48'53''$ East 507.71 feet to the Point of Beginning.

The above described tract of land contains 9.27 acres, more or less.

Bearings for this description are based on State Plane Grid bearing, Oregon State Plane, North Zone 3601, NAD83(2011) Epoch: 2010.0000. Distances shown are International Foot ground values.

4/22/2021

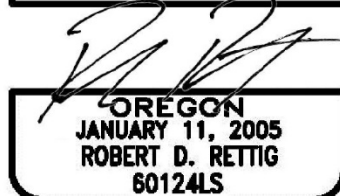

RENEWS: 12/31/22

EXHIBIT B

A TRACT OF LAND, AND A PORTION OF RIGHT-OF-WAY,
 LOCATED IN THE NORTHWEST AND SOUTHWEST 1/4 OF SECTION 7,
 TOWNSHIP 3 SOUTH, RANGE 1 EAST, AND
 THE NORTHEAST AND SOUTHWEST 1/4 OF SECTION 12,
 TOWNSHIP 3 SOUTH, RANGE 1 WEST, WILLAMETTE MERIDIAN,
 CLACKAMAS COUNTY, OREGON

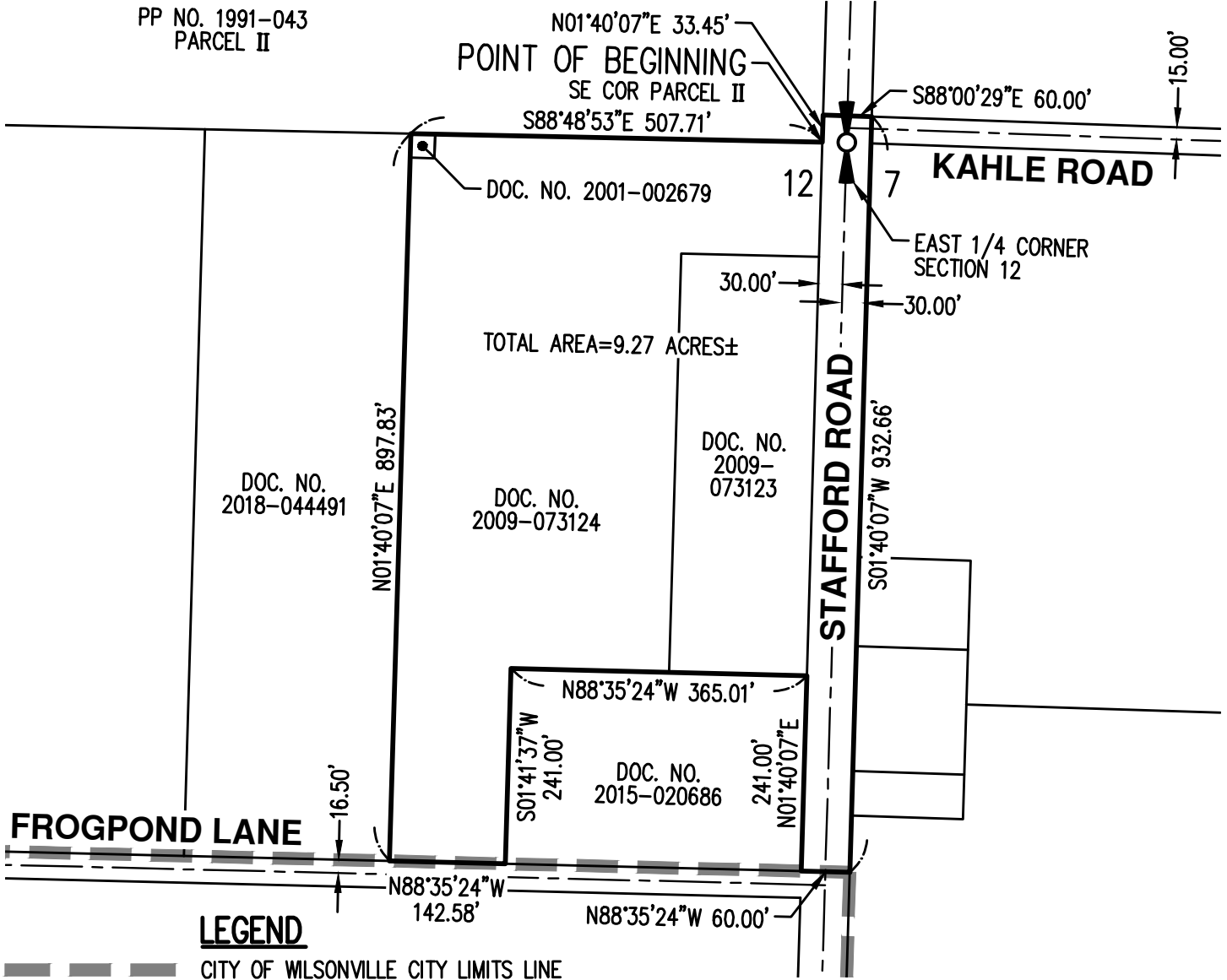

4/22/2021

REGISTERED
 PROFESSIONAL
 LAND SURVEYOR

PREPARED FOR

VENTURE PROPERTIES, INC.
 4230 SW GALEWOOD STREET, SUITE 100
 LAKE OSWEGO, OR 97035

SCALE: 1" = 200 FEET

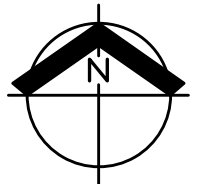

[Signature]

OREGON
 JANUARY 11, 2005
 ROBERT D. RETTIG
 60124LS

RENEWS: 12/31/22

ZONE CHANGE MAP

AKS ENGINEERING & FORESTRY, LLC
 12965 SW HERMAN RD, STE 100
 TUALATIN, OR 97062
 503.563.6151 WWW.AKS-ENG.COM



EXHIBIT
B

DRWN: WCB
 CHKD: RDR

AKS JOB:
 5252

Exhibit M: Preliminary Conceptual Elevations

*SQUARE FOOTAGE IS AN ESTIMATED FIGURE, IT MAY VARY.
 *ALL DIMENSIONS ARE ESTIMATES, SOME MAY VARY.
 *PLANS ARE DESIGNED FOR FLAT LOTS. IF MASONRY IS INCLUDED IN PLAN, THERE IS AN ADDITIONAL CHARGE IF HOME SITE IS NOT FLAT.
 *ARCHITECTURAL DRAWINGS ARE ESTIMATES OF HOW HOME WILL LOOK.

GLAZING REQUIREMENTS

ELEVATION TWO-STORY	TOTAL WALL AREA	MIN. AREA REQUIRED	ACTUAL AREA ON ELEVATION
FRONT-TOTAL	684 sq.ft.	15% = 103 sq.ft.	24.7% = 169 sq.ft.

ARTICULATION:
 2 MIN. ON FRONT

1. VARYING ROOFLINE
2. OFFSET

RESIDENTIAL DESIGN MENU:
 5 MIN. ON FRONT

7. DECORATIVE DIAGONAL BRACING AT PORCH COLUMNS
8. DECORATIVE MOLDING ABOVE WINDOWS AND DOORS
12. WINDOW IN FRONT DOOR
13. WINDOW GRIDS ON ALL FACADE WINDOWS
14. GARAGE WITH WINDOWS AND DECORATIVE TRIM

RIDGELINE
 29'-9 1/2" AFF

TOP PLATE HEIGHT
 10'-1 1/8"

SECOND FLR HEIGHT
 10'-1 1/8"

TOP PLATE
 9'-0"

FINISHED FLR HEIGHT
 0'-0"

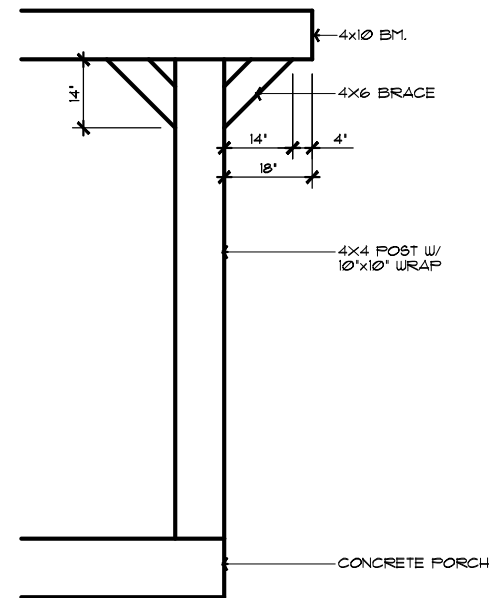

COLUMN DETAIL
 1/2" = 1'-0"



STONE BRIDGE
SB
 HOMES NW

PLAN No. RX308-FH
 DRAWN BY: GF
 DATE: 6/24/21
 SCALE: 1/4" = 1'-0"
 FILE: RX308MOD-FH-1

DRAWINGS:
 EXTERIOR ELEVATION
 CONTEMP. FARMHOUSE

SHEET No.
1
 RX308mod
 FARMHOUSE
 2,907 SQ.FT.



REAR ELEVATION-INTERIOR
1/4"=1'-0"

PLAN No.	RX308-FH
DRAWN BY:	GF
DATE:	6/24/21
SCALE:	1/4"=1'-0"
FILE:	RX308MOD-FH-2A

DRAWINGS:

**EXTERIOR
ELEVATION**

**CONTEMP.
FARMHOUSE**

SHEET No.

2A

**RX308mod
FARMHOUSE
2,907 SQ.FT.**

TOP PLATE HEIGHT
10'-1 1/8"

SECOND FLR. HEIGHT
10'-1 1/8"

TOP PLATE
9'-0"

FINISHED FLR. HEIGHT
0'-0"

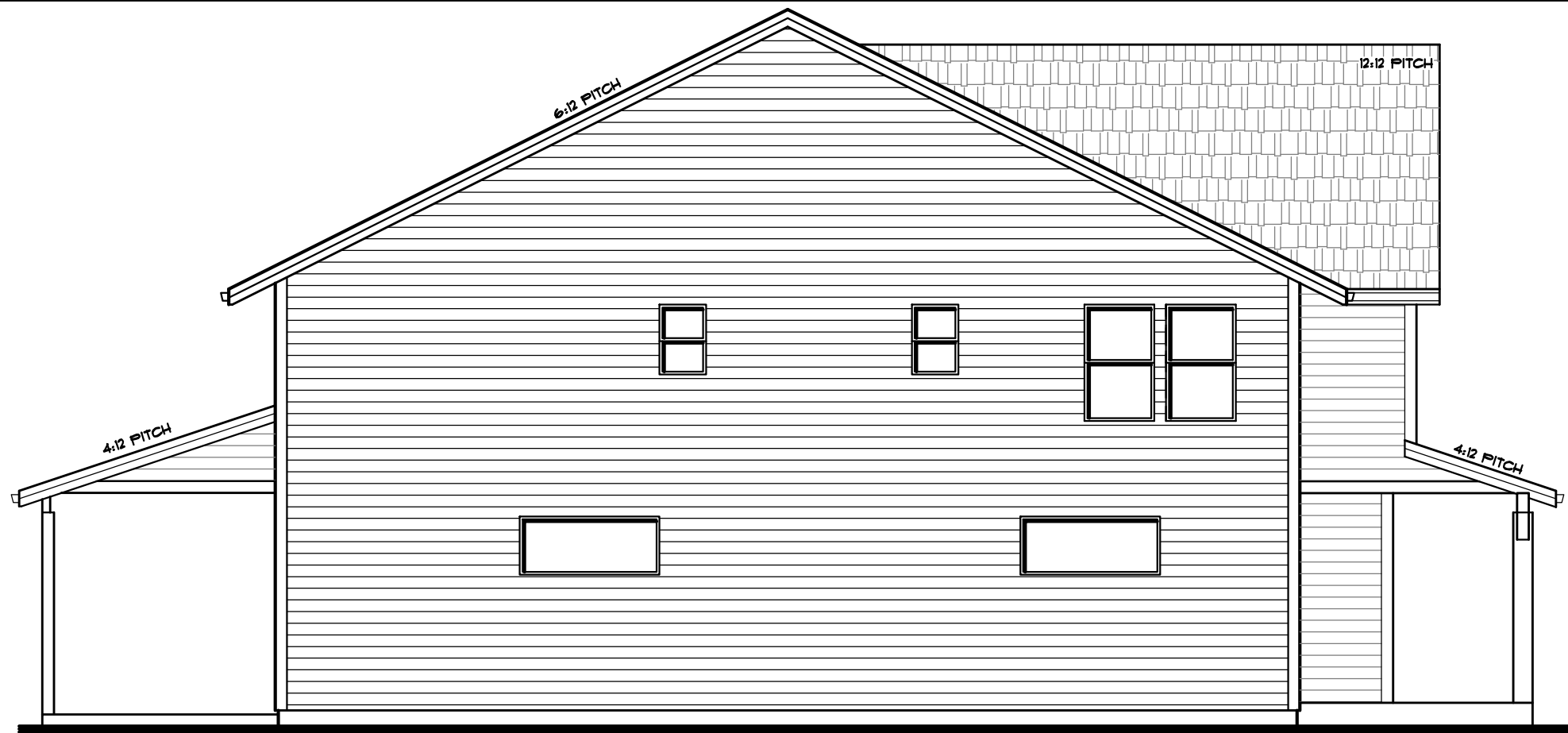

SIDE A ELEVATION-INTERIOR

1/4"=1'-0"

TOP PLATE HEIGHT
10'-1 1/8"

SECOND FLR. HEIGHT
10'-1 1/8"

TOP PLATE
9'-0"

FINISHED FLR. HEIGHT
0'-0"



SIDE B ELEVATION-INTERIOR

1/4"=1'-0"

STONE BRIDGE
HOMES NW



PLAN No.	RX308-FH
DRAWN BY:	GF
DATE:	6/24/21
SCALE:	1/4"=1'-0"
FILE:	RX308MOD-FH-2B

DRAWINGS:

**EXTERIOR
ELEVATION**

**CONTEMP.
FARMHOUSE**

SHEET No.

2B

**RX308mod
FARMHOUSE
2,907 SQ.FT.**

*SQUARE FOOTAGE IS AN ESTIMATED FIGURE, IT MAY VARY.
 *ALL DIMENSIONS ARE ESTIMATES, SOME MAY VARY.
 *PLANS ARE DESIGNED FOR FLAT LOTS. IF MASONRY IS INCLUDED IN PLAN, THERE IS AN ADDITIONAL CHARGE IF HOME SITE IS NOT FLAT.
 *ARCHITECTURAL DRAWINGS ARE ESTIMATES OF HOW HOME WILL LOOK.

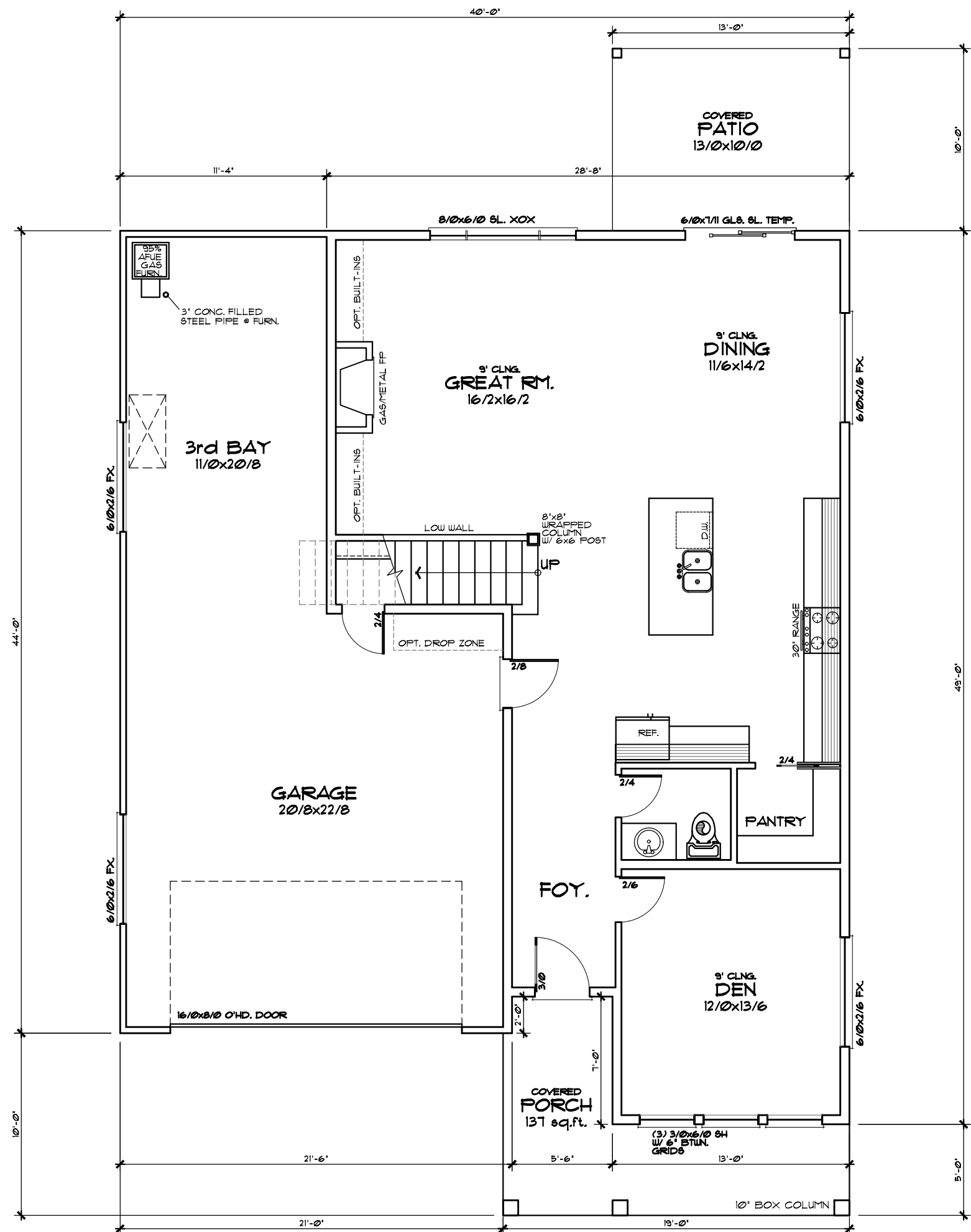

MAIN FLOOR PLAN
 1/4" = 1'-0"
 1,092 SQ. FT.
 GARAGE: 722 SQ. FT.

STONE BRIDGE
 HOMES NW



PLAN No. RX308-FH
 DRAWN BY: GF
 DATE: 6/24/21
 SCALE: 1/4" = 1'-0"
 FILE: RX308MOD-FH-3

DRAWINGS:
MAIN FLOOR PLAN
 CONTEMP. FARMHOUSE

SHEET No.
3
 RX308mod FARMHOUSE
 2,907 SQ.FT.

*SQUARE FOOTAGE IS AN ESTIMATED FIGURE, IT MAY VARY.
 *ALL DIMENSIONS ARE ESTIMATES, SOME MAY VARY.
 *PLANS ARE DESIGNED FOR FLAT LOTS. IF MASONRY IS INCLUDED IN PLAN, THERE IS AN ADDITIONAL CHARGE IF HOME SITE IS NOT FLAT.
 *ARCHITECTURAL DRAWINGS ARE ESTIMATES OF HOW HOME WILL LOOK.

WINDOW STANDARDS			
ELEVATION	TOTAL WALL AREA	MIN. AREA REQUIRED	ACTUAL AREA ON ELEVATION
TWO-STORY	579 sq.ft.	15% = 87 sq.ft.	15.2% = 88 sq.ft.
FRONT-TOTAL			

ARTICULATION:
 2 MIN. ON FRONT

1. VARYING ROOFLINE - HIPPED WITH FRONT GABLE
2. OFFSET
4. OVERHANG PROJECTION AT SECOND FLOOR

RESIDENTIAL DESIGN MENU:
 5 MIN. ON FRONT

2. COVERED FRONT PORCH (MIN. 48sf COVERED, MIN. 6' DEEP AND MIN. 6' COVERED)
3. FRONT PORCH RAILING AT TWO SIDES OF PORCH
8. DECORATIVE MOLDING ABOVE WINDOWS AND DOORS
10. STAGGERED LAP SIDING, MIN 6@sf
12. WINDOW IN FRONT DOOR

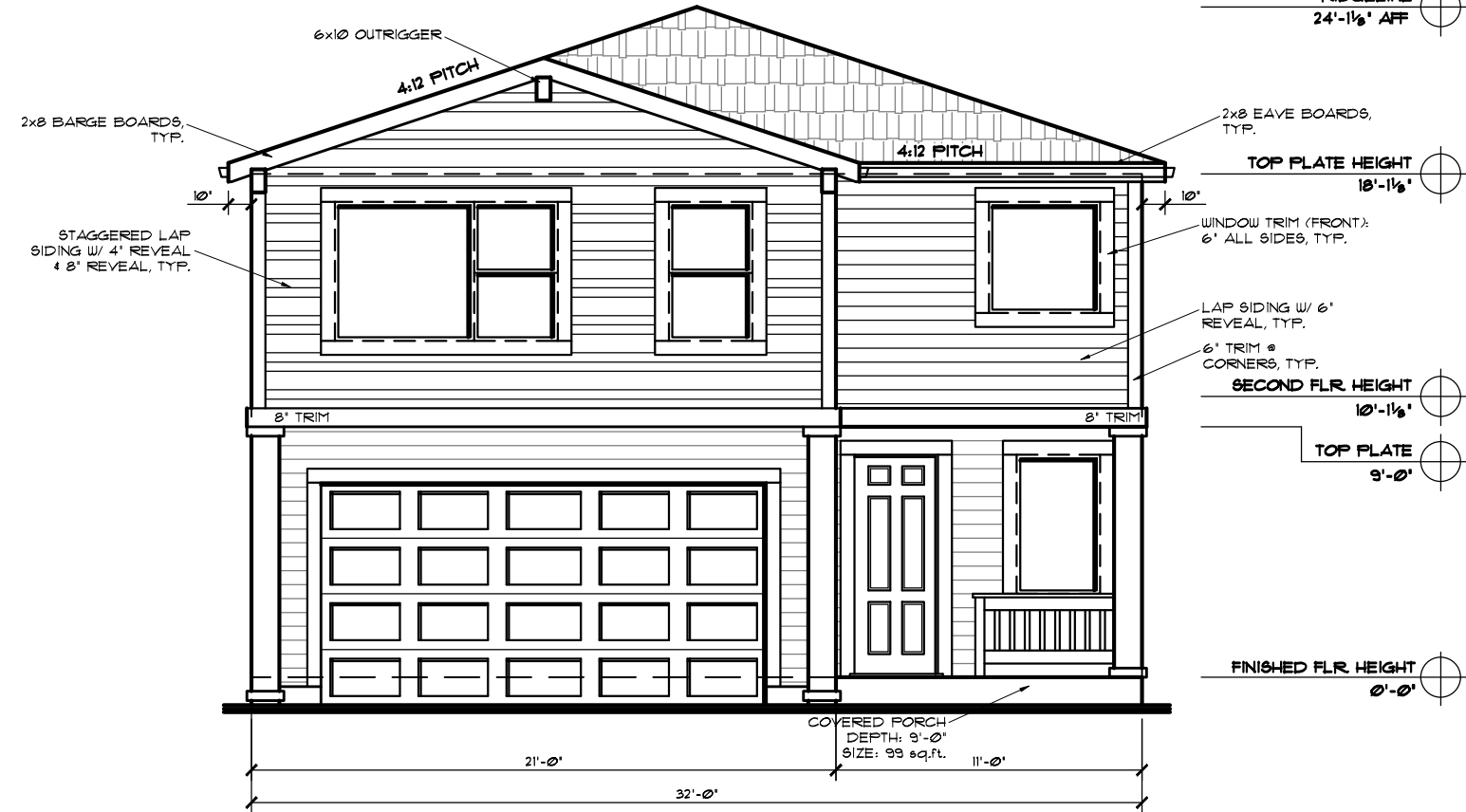

FRONT ELEVATION

1/4" = 1'-0"



REAR ELEVATION

1/4" = 1'-0"

STONE BRIDGE
 HOMES NW

PLAN No. 623-OPT.3
 DRAWN BY: GF
 DATE: 6/23/21
 SCALE: 1/4" = 1'-0"
 FILE: 623MOD-1

DRAWINGS:
EXTERIOR ELEVATION

SHEET No.

1

623mod
CONTEMP.
2,890 SQ.FT.

*SQUARE FOOTAGE IS AN ESTIMATED FIGURE, IT MAY VARY.
 *ALL DIMENSIONS ARE ESTIMATES, SOME MAY VARY.
 *PLANS ARE DESIGNED FOR FLAT LOTS. IF MASONRY IS INCLUDED IN PLAN, THERE IS AN ADDITIONAL CHARGE IF HOME SITE IS NOT FLAT.
 *ARCHITECTURAL DRAWINGS ARE ESTIMATES OF HOW HOME WILL LOOK.

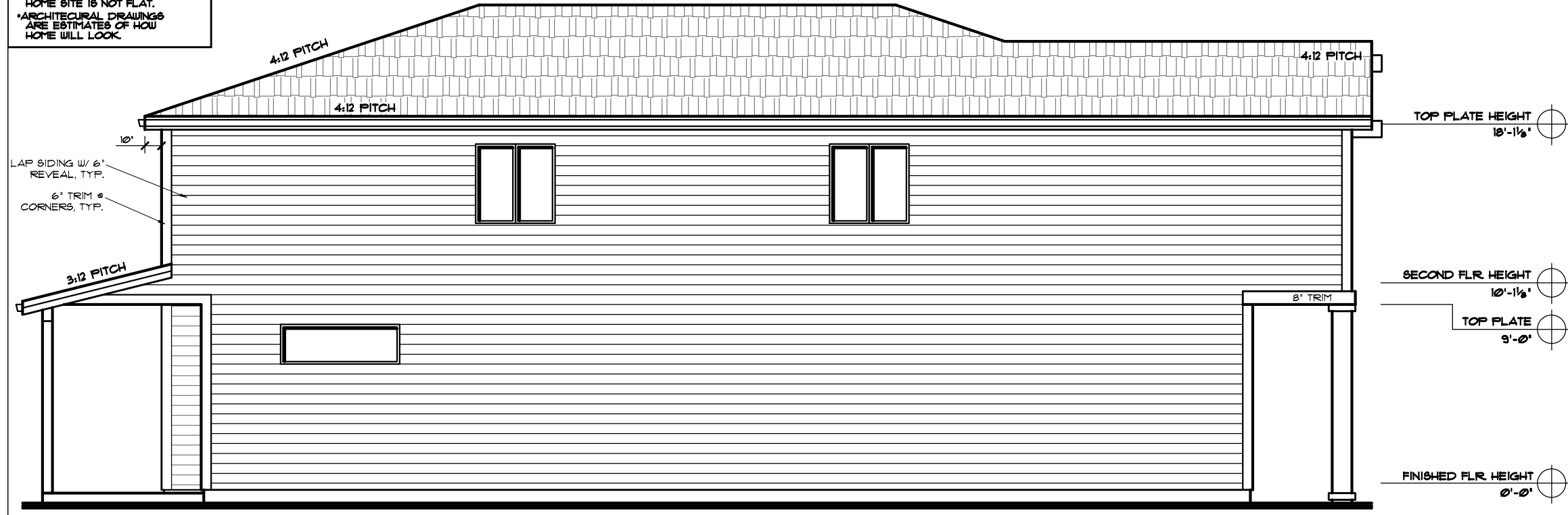

LEFT ELEVATION

1/4"=1'-0"



RIGHT ELEVATION

1/4"=1'-0"

STONE BRIDGE
 HOMES NW

PLAN No.	623-OPT.3
DRAWN BY:	GF
DATE:	6/23/21
SCALE:	1/4"=1'-0"
FILE:	623MOD-2

DRAWINGS:
EXTERIOR ELEVATION

SHEET No.
2
623mod
CONTEMP.
2,890 SQ.FT.

*SQUARE FOOTAGE IS AN ESTIMATED FIGURE, IT MAY VARY.
 *ALL DIMENSIONS ARE ESTIMATES, SOME MAY VARY.
 *PLANS ARE DESIGNED FOR FLAT LOTS. IF MASONRY IS INCLUDED IN PLAN, THERE IS AN ADDITIONAL CHARGE IF HOME SITE IS NOT FLAT.
 *ARCHITECTURAL DRAWINGS ARE ESTIMATES OF HOW HOME WILL LOOK.

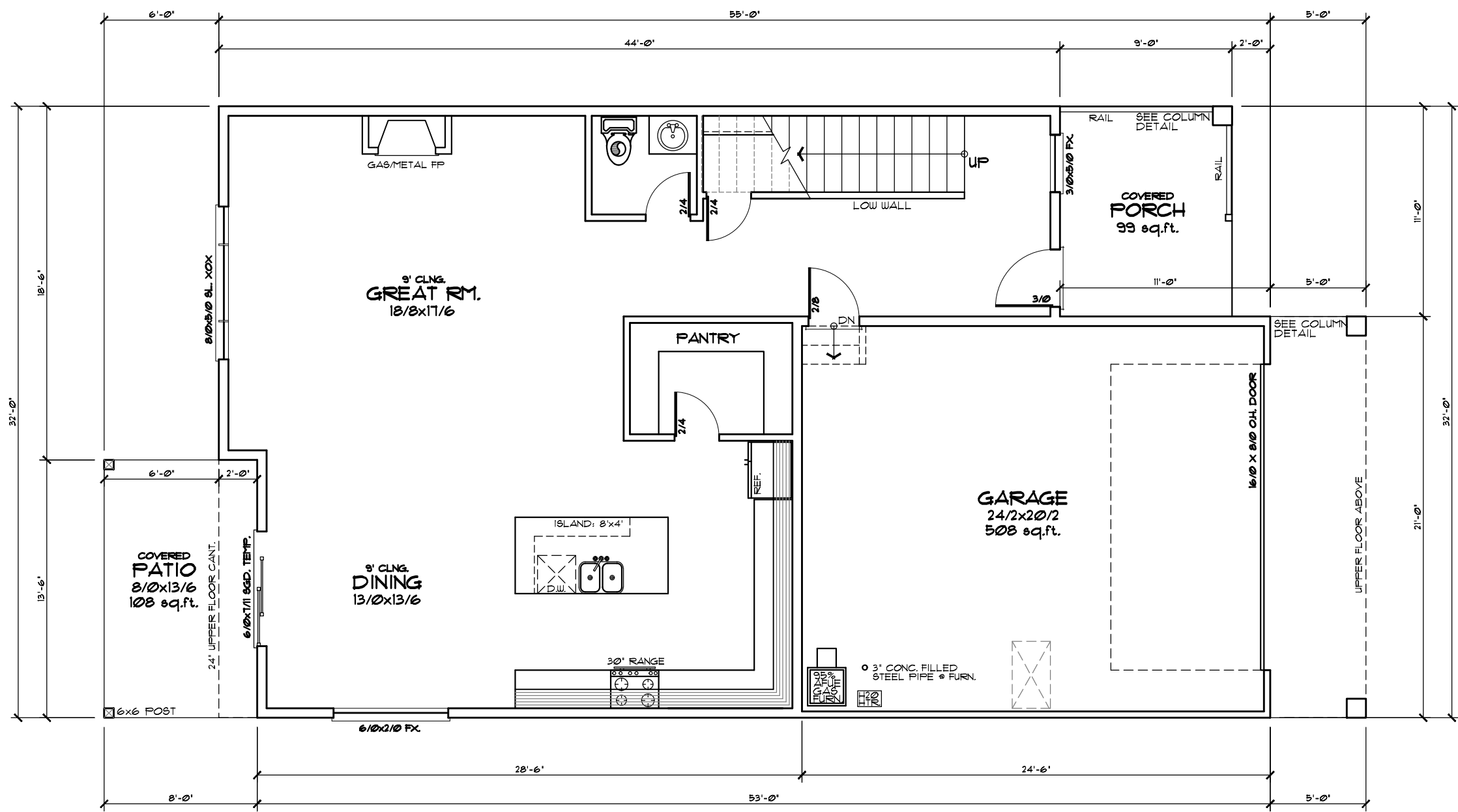
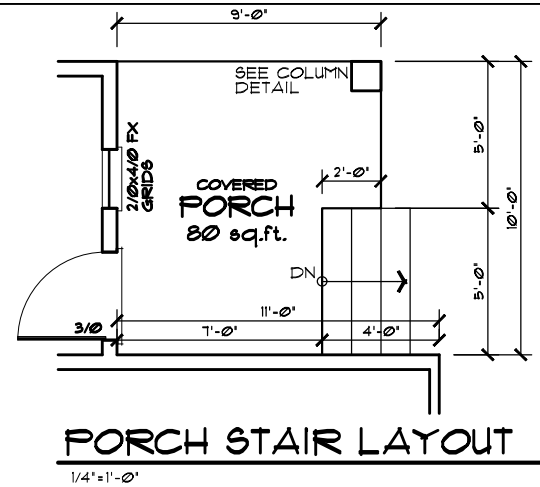
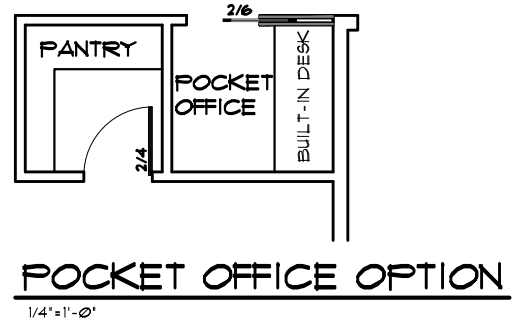

MAIN FLOOR PLAN
 1/4"=1'-0" 1,104 SQ. FT.
 GARAGE: 508 SQ. FT.

STONE BRIDGE HOMES NW

PLAN No.	623-OPT.3
DRAWN BY:	GF
DATE:	6/23/21
SCALE:	1/4"=1'-0"
FILE:	623MOD-3

DRAWINGS:
MAIN FLOOR PLAN

SHEET No.
3
623mod
CONTEMP.
2,890 SQ.FT.

*SQUARE FOOTAGE IS AN ESTIMATED FIGURE, IT MAY VARY.
 *ALL DIMENSIONS ARE ESTIMATES, SOME MAY VARY.
 *PLANS ARE DESIGNED FOR FLAT LOTS. IF MASONRY IS INCLUDED IN PLAN, THERE IS AN ADDITIONAL CHARGE IF HOME SITE IS NOT FLAT.
 *ARCHITECTURAL DRAWINGS ARE ESTIMATES OF HOW HOME WILL LOOK.

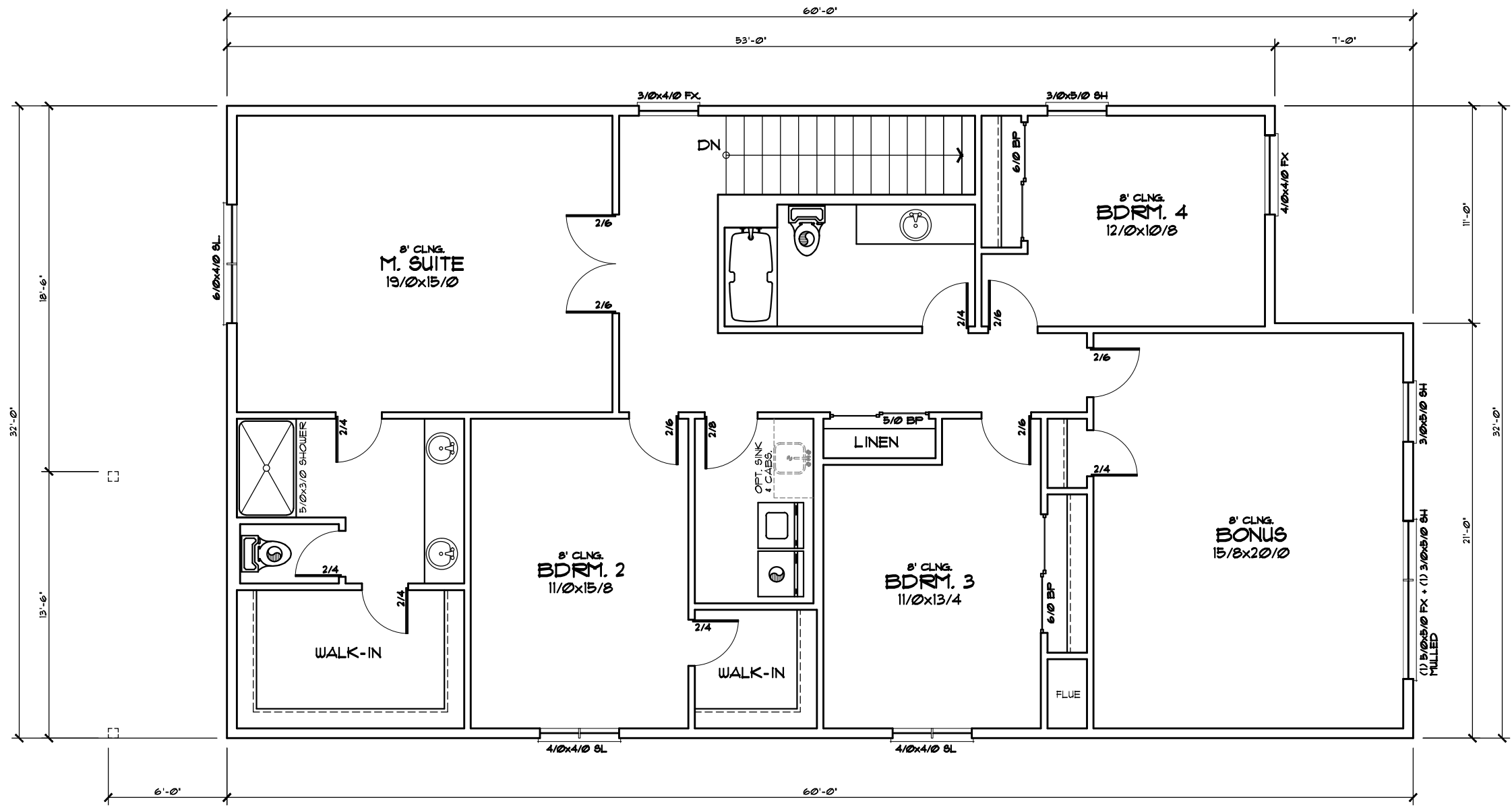

UPPER FLOOR PLAN
 1/4"=1'-0"
 1,786 SQ. FT.



PLAN No. 623-OPT.3
 DRAWN BY: GF
 DATE: 6/23/21
 SCALE: 1/4"=1'-0"
 FILE: 623MOD-4

DRAWINGS:
 UPPER FLOOR PLAN

SHEET No.
4
 623mod
 CONTEMP.
 2,890 SQ.FT.

*SQUARE FOOTAGE IS AN ESTIMATED FIGURE, IT MAY VARY.
 *ALL DIMENSIONS ARE ESTIMATES, SOME MAY VARY.
 *PLANS ARE DESIGNED FOR FLAT LOTS. IF MASONRY IS INCLUDED IN PLAN, THERE IS AN ADDITIONAL CHARGE IF HOME SITE IS NOT FLAT.
 *ARCHITECTURAL DRAWINGS ARE ESTIMATES OF HOW HOME WILL LOOK.

ARTICULATION:
 2 MIN. ON FRONT
 1. VARYING ROOFLINE
 2. OFFSET

RESIDENTIAL DESIGN MENU:
 5 MIN. ON FRONT
 1. DORMER
 2. COVERED PORCH
 8. DECORATIVE MOLDING ABOVE WINDOWS & DOORS
 12. WINDOW IN FRONT DOOR
 13. WINDOW GRIDS

WINDOW STANDARDS			
ELEVATION	TOTAL WALL AREA	MIN. AREA REQUIRED	ACTUAL AREA ON ELEVATION
TWO-STORY	640 sq.ft.	12.5% = 80 sq.ft.	24.5% = 157 sq.ft.
FRONT-TOTAL			

FRONT ELEVATION

1/4"=1'-0"

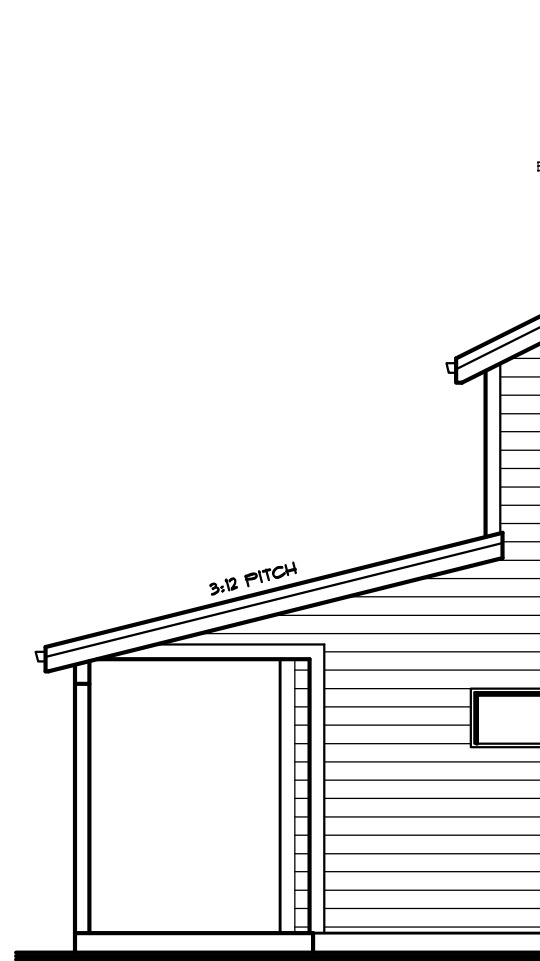
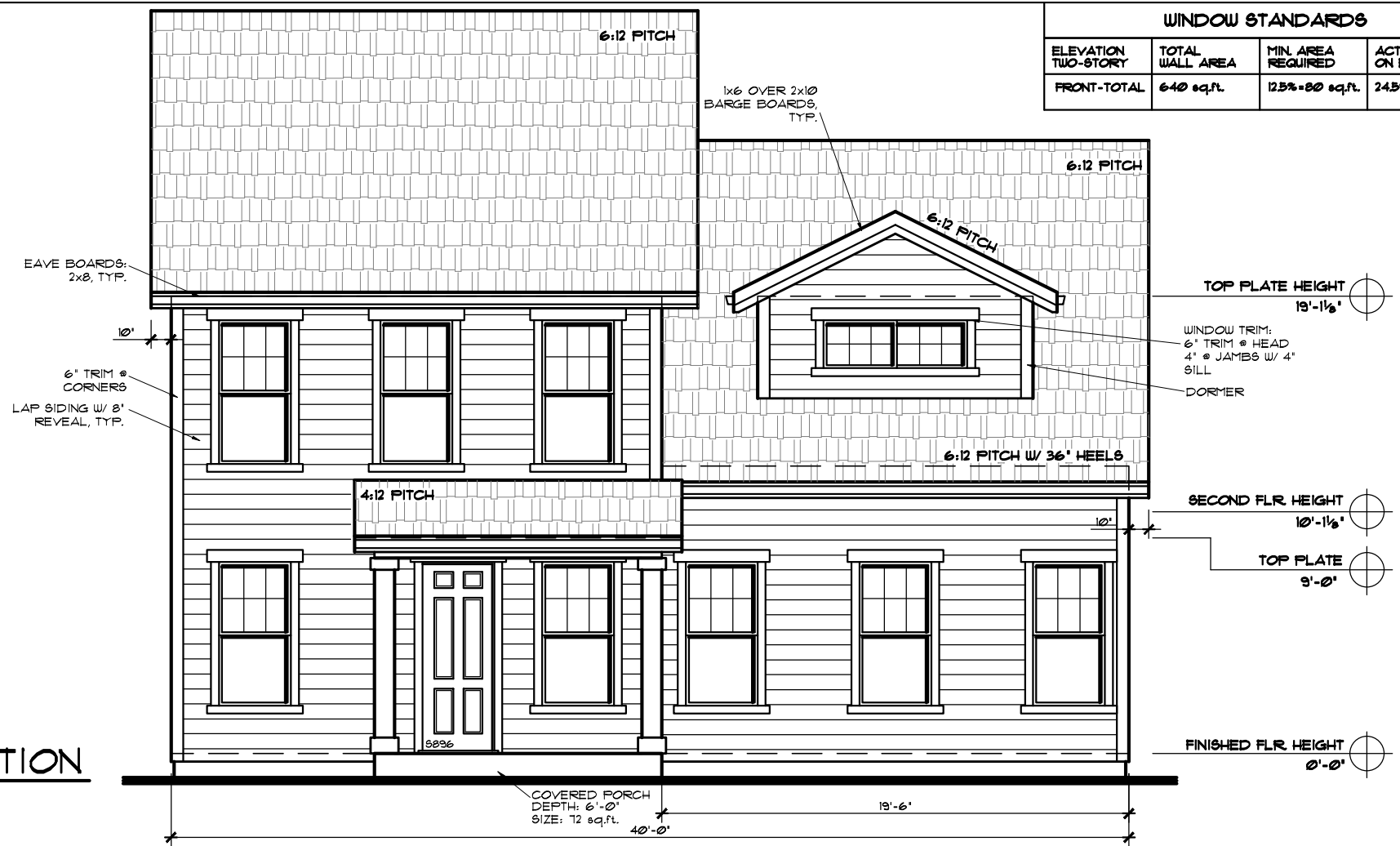

SIDE A ELEVATION

1/4"=1'-0"

STONE BRIDGE HOMES NW

PLAN No.	442mod-STD
DRAWN BY:	GF
DATE:	6/4/21
SCALE:	1/4"=1'-0"
FILE:	442mod-1

DRAWINGS:
EXTERIOR ELEVATION

SHEET No.
1
442mod
STANDARD
2,682 SQ.FT.

*SQUARE FOOTAGE IS AN ESTIMATED FIGURE, IT MAY VARY.
 *ALL DIMENSIONS ARE ESTIMATES, SOME MAY VARY.
 *PLANS ARE DESIGNED FOR FLAT LOTS. IF MASONRY IS INCLUDED IN PLAN, THERE IS AN ADDITIONAL CHARGE IF HOME SITE IS NOT FLAT.
 *ARCHITECTURAL DRAWINGS ARE ESTIMATES OF HOW HOME WILL LOOK.

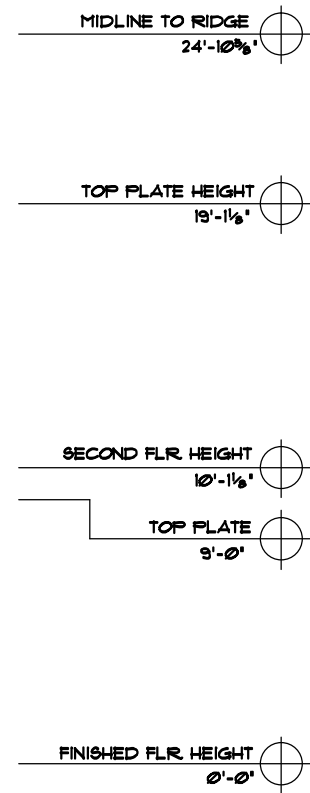

REAR ELEVATION

1/4"=1'-0"

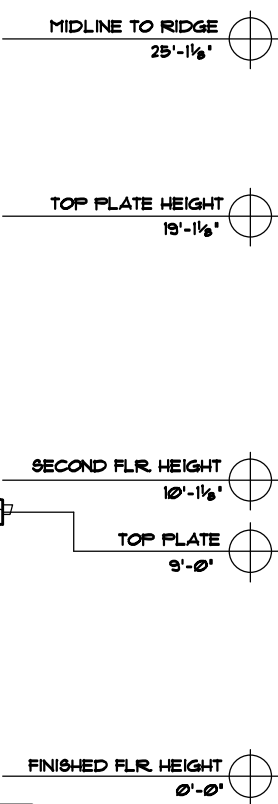

SIDE B ELEVATION

1/4"=1'-0"



PLAN No.	442mod-STD
DRAWN BY:	GF
DATE:	6/3/21
SCALE:	1/4"=1'-0"
FILE:	442mod-2

DRAWINGS:
EXTERIOR ELEVATION

SHEET No.
2
442mod
STANDARD
2,682 SQ.FT.

*SQUARE FOOTAGE IS AN ESTIMATED FIGURE, IT MAY VARY.
 *ALL DIMENSIONS ARE ESTIMATES, SOME MAY VARY.
 *PLANS ARE DESIGNED FOR FLAT LOTS. IF MASONRY IS INCLUDED IN PLAN, THERE IS AN ADDITIONAL CHARGE IF HOME SITE IS NOT FLAT.
 *ARCHITECTURAL DRAWINGS ARE ESTIMATES OF HOW HOME WILL LOOK.

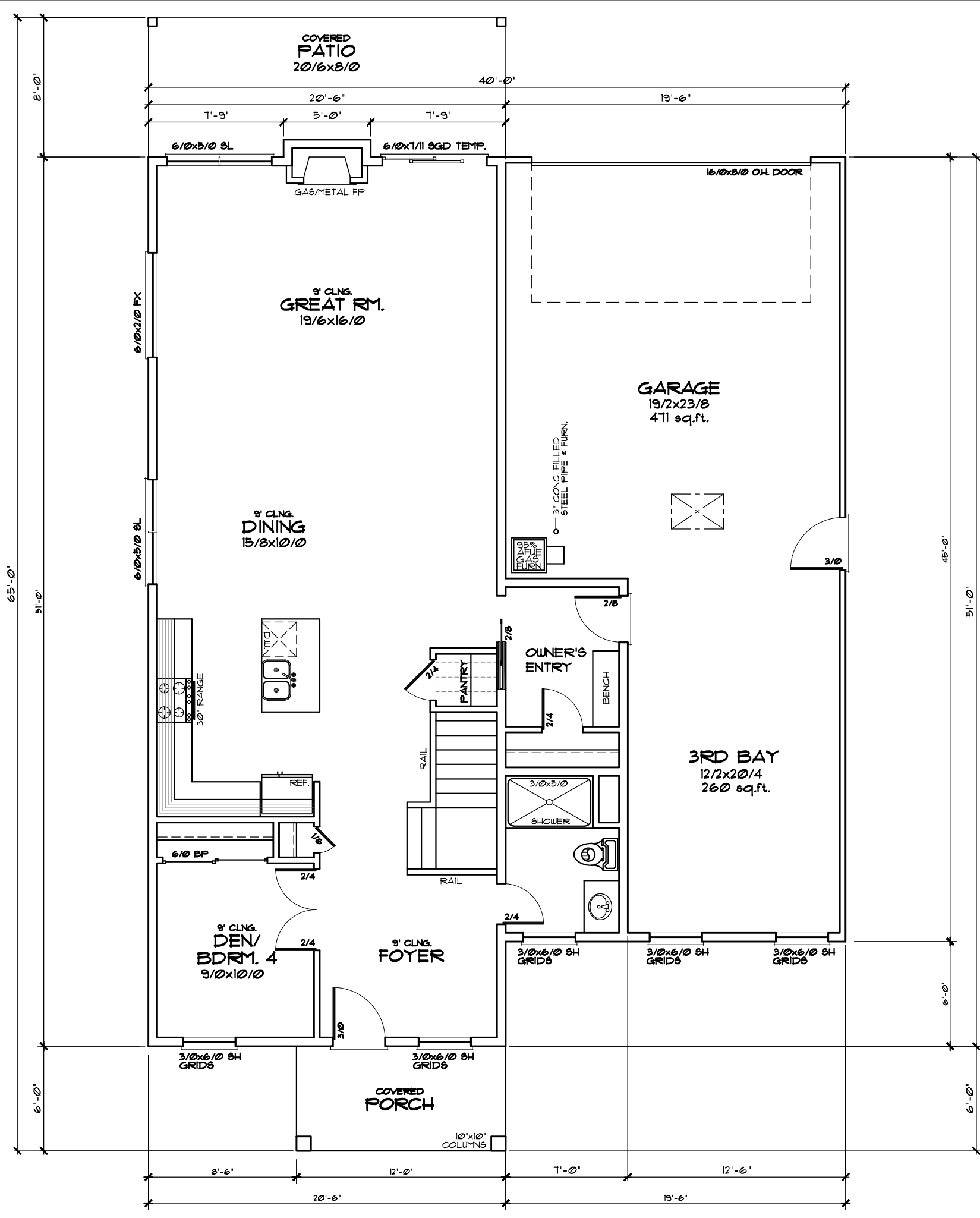

MAIN FLOOR PLAN
 1/4"=1'-0"
 1,191 SQ.FT.
 GARAGE: 131 SQ.FT.

STONE BRIDGE
 HOMES NW



PLAN No. 442mod-STD
 DRAWN BY: GF
 DATE: 6/3/21
 SCALE: 1/4"=1'-0"
 FILE: 442mod-3

DRAWINGS:
MAIN FLOOR PLAN

SHEET No.
3
 442mod
 STANDARD
 2,682 SQ.FT.

*SQUARE FOOTAGE IS AN ESTIMATED FIGURE, IT MAY VARY.
 *ALL DIMENSIONS ARE ESTIMATES, SOME MAY VARY.
 *PLANS ARE DESIGNED FOR FLAT LOTS. IF MASONRY IS INCLUDED IN PLAN, THERE IS AN ADDITIONAL CHARGE IF HOME SITE IS NOT FLAT.
 *ARCHITECTURAL DRAWINGS ARE ESTIMATES OF HOW HOME WILL LOOK.

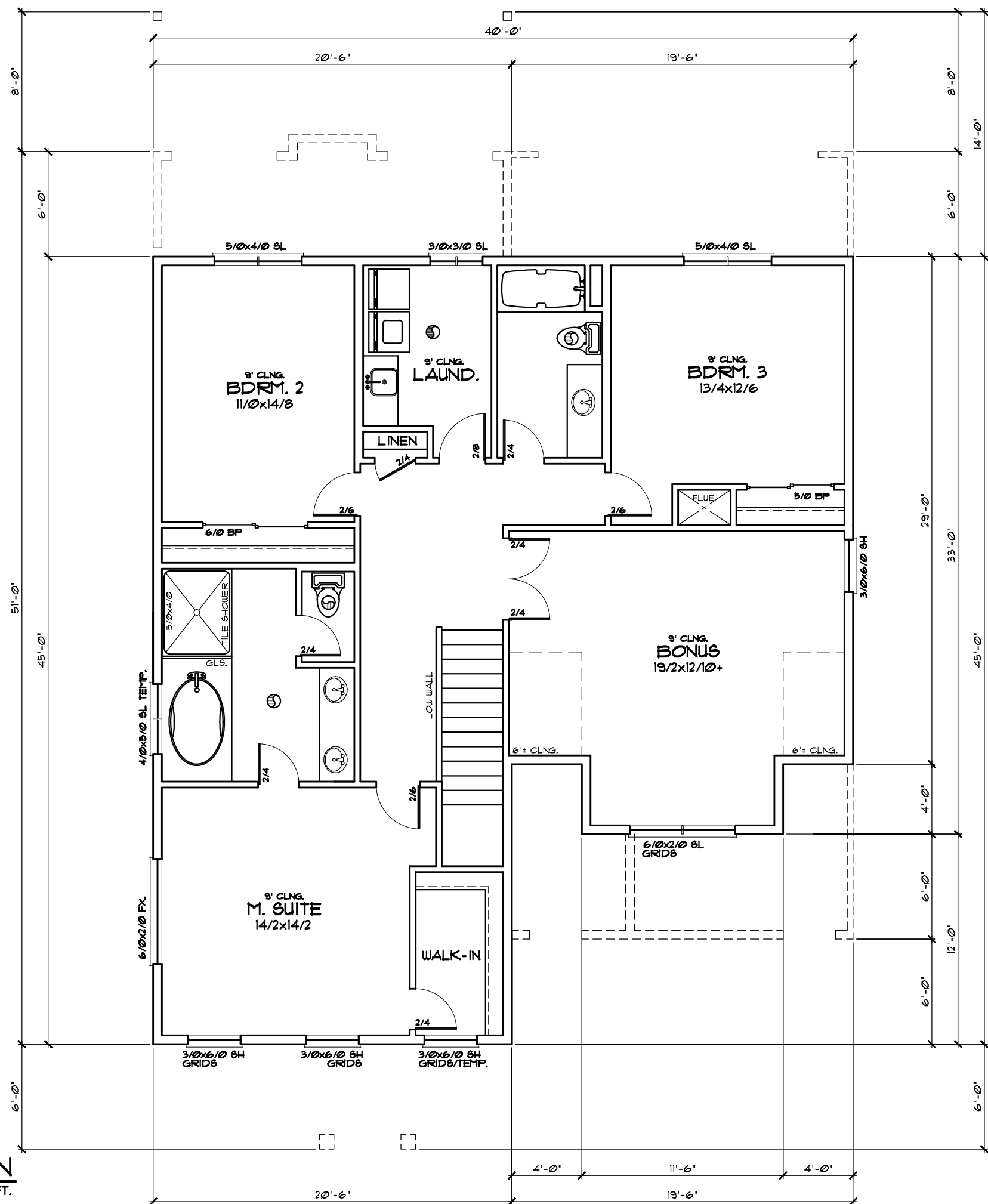

UPPER FLOOR PLAN
 1/4"=1'-0" 1,491 SQ.FT.

STONE BRIDGE
 HOMES NW



PLAN No. 442mod-STD
 DRAWN BY: GF
 DATE: 6/3/21
 SCALE: 1/4"=1'-0"
 FILE: 442mod-4

UPPER
 FLOOR
 PLAN

SHEET No.

4

442mod
 STANDARD
 2,682 SQ.FT.

*SQUARE FOOTAGE IS AN ESTIMATED FIGURE, IT MAY VARY.
 *ALL DIMENSIONS ARE ESTIMATES, SOME MAY VARY.
 *PLANS ARE DESIGNED FOR FLAT LOTS. IF MASONRY IS INCLUDED IN PLAN, THERE IS AN ADDITIONAL CHARGE IF HOME SITE IS NOT FLAT.
 *ARCHITECTURAL DRAWINGS ARE ESTIMATES OF HOW HOME WILL LOOK.

ARTICULATION:
 2 MIN. ON FRONT
 1. VARYING ROOFLINE
 2. OFFSET

RESIDENTIAL DESIGN MENU:
 5 MIN. ON FRONT
 2. COVERED PORCH
 3. FRONT PORCH RAILING
 10. STAINED CEDAR LAP MIN. 60sf
 12. WINDOW IN FRONT DOOR
 15. MASONRY BASE MATERIAL

WINDOW STANDARDS			
ELEVATION TWO-STORY	TOTAL WALL AREA	MIN. AREA REQUIRED	ACTUAL AREA ON ELEVATION
FRONT-TOTAL	710 sq.ft.	15% = 107 sq.ft.	38.9% = 276 sq.ft.

MASONRY STANDARDS			
ELEVATION TWO-STORY	TOTAL WALL AREA	MIN. AREA REQUIRED	ACTUAL AREA ON ELEVATION
FRONT-TOTAL	710 sq.ft.	10% = 71 sq.ft.	10.8% = 77 sq.ft.

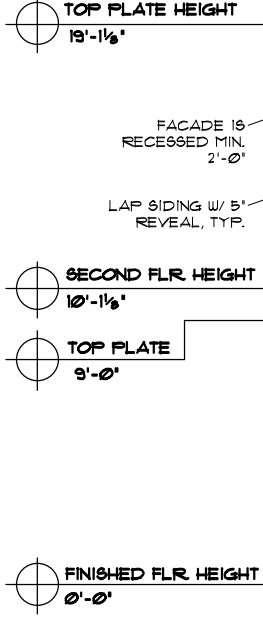

FRONT ELEVATION
 1/4" = 1'-0"

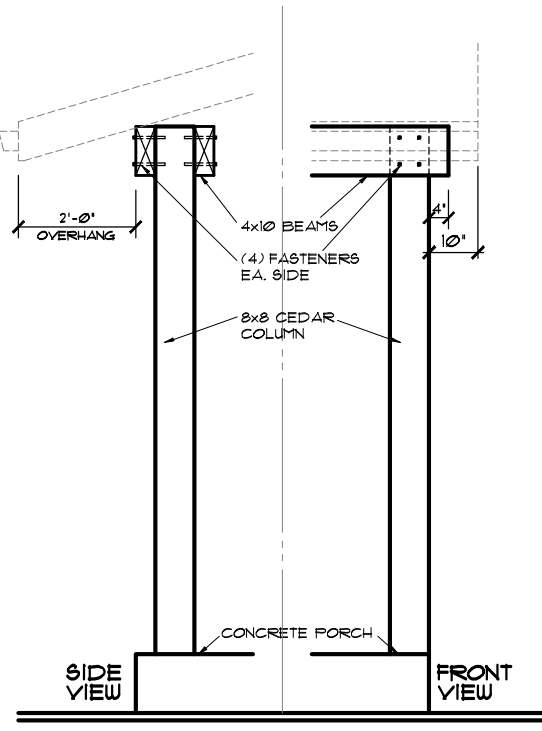

COLUMN DETAIL
 1/2" = 1'-0"



REAR ELEVATION
 1/4" = 1'-0"

STONE BRIDGE
 HOMES NW



PLAN No. 444mod-PNUM
 DRAWN BY: GF
 DATE: 6/4/2021
 SCALE: 1/4" = 1'-0"
 FILE: 444mod-1

DRAWINGS:
EXTERIOR ELEVATION

SHEET No.
1
 444mod
 PNWM
 2,760 SQ.FT.

*SQUARE FOOTAGE IS AN ESTIMATED FIGURE, IT MAY VARY.
 *ALL DIMENSIONS ARE ESTIMATES, SOME MAY VARY.
 *PLANS ARE DESIGNED FOR FLAT LOTS. IF MASONRY IS INCLUDED IN PLAN, THERE IS AN ADDITIONAL CHARGE IF HOME SITE IS NOT FLAT.
 *ARCHITECTURAL DRAWINGS ARE ESTIMATES OF HOW HOME WILL LOOK.

TOP PLATE HEIGHT
19'-1 1/2"

SECOND FLR HEIGHT
10'-1 1/2"

TOP PLATE
9'-0"

FINISHED FLR HEIGHT
0'-0"

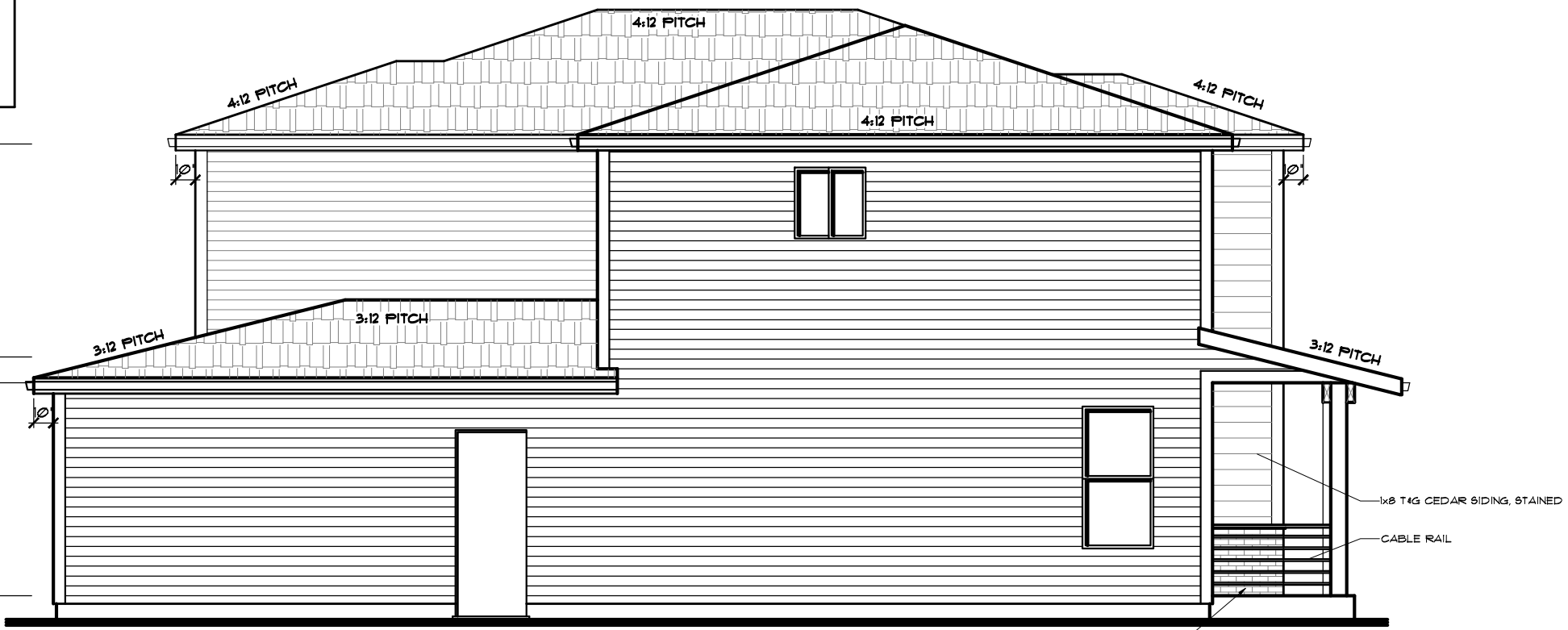

LEFT ELEVATION
1/4" = 1'-0"

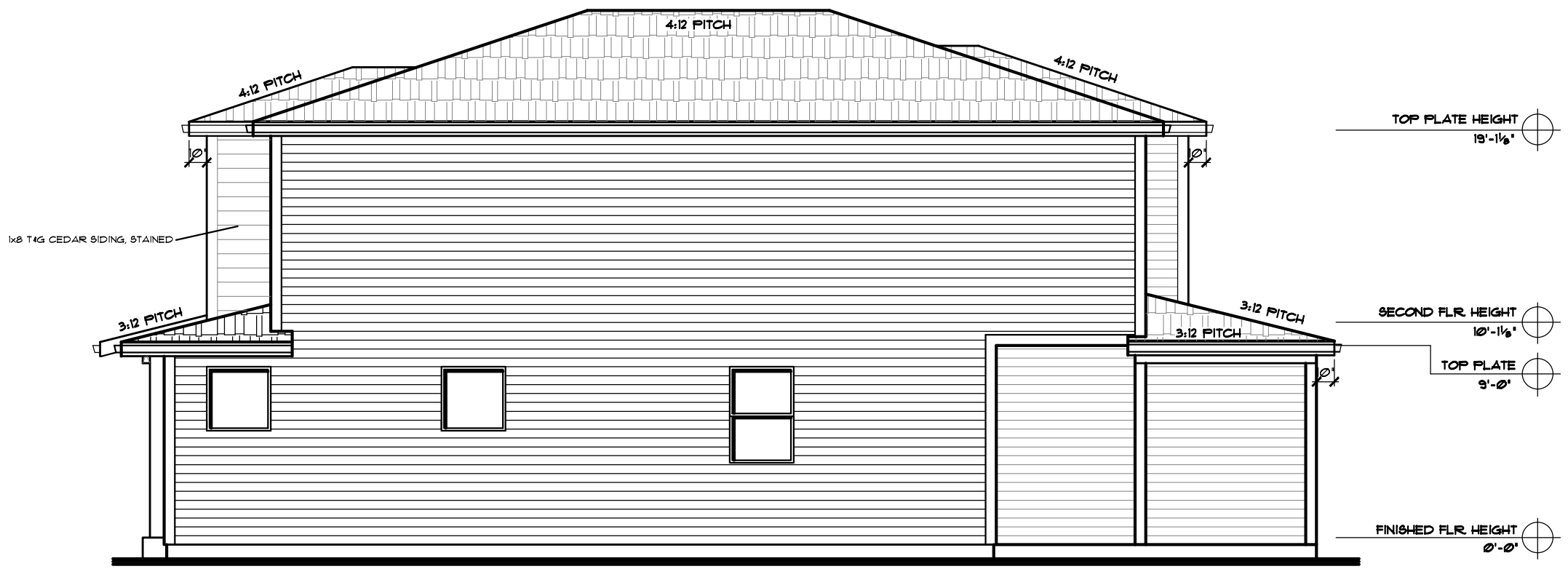

RIGHT ELEVATION
1/4" = 1'-0"

STONE BRIDGE
HOMES NW

PLAN No. 444mod-PNWM
 DRAWN BY: GF
 DATE: 6/4/2021
 SCALE: 1/4" = 1'-0"
 FILE: 444mod-2

DRAWINGS:
EXTERIOR ELEVATION

PNWM

SHEET No.

2

444mod
PNWM
2,760 SQ.FT.

*SQUARE FOOTAGE IS AN ESTIMATED FIGURE, IT MAY VARY.
 *ALL DIMENSIONS ARE ESTIMATES, SOME MAY VARY.
 *PLANS ARE DESIGNED FOR FLAT LOTS. IF MASONRY IS INCLUDED IN PLAN, THERE IS AN ADDITIONAL CHARGE IF HOME SITE IS NOT FLAT.
 *ARCHITECTURAL DRAWINGS ARE ESTIMATES OF HOW HOME WILL LOOK.

GENERAL NOTES:

- 9'-0" CEILING THRU-OUT MAIN FLOOR PLAN
- 4 X 10 HEADERS TYP. UNLESS NOTED OTHERWISE
- VOIDS IN HEADERS TO BE INSULATED W/ MIN. R-4 RIGID INSULATION
- NON-STRUCTURAL HEADERS MAY BE REPLACED ENTIRELY W/ RIGID INSULATION
- FULL-HEIGHT STUDS REQUIRED AT EACH END OF HEADERS PER R602.15
- LESS THAN 3'-0" = 1 STUD
- LESS THAN 4'-0" = 2 STUDS
- LESS THAN 5'-0" = 3 STUDS
- LESS THAN 12'-0" = 5 STUDS
- LESS THAN 16'-0" = 6 STUDS
- INTERMEDIATE FRAMING FOR EXTERIOR WALLS, TYP.: 2 X 6 STUDS @ 16" O.C. W/ R-23 BLOWN INSULATION
- CORNERS & INTERSECTIONS, TYP. TO BE FULLY INSULATED THRU 2- OR 3- STUD CORNER TECHNIQUE PER N104.5.2
- INTERMEDIATE FRAMING FOR INTERIOR WALLS, TYP.: 2 X 4 STUDS @ 16" O.C.
- INTERSECTIONS W/ EXTERIOR WALLS TO BE FULLY INSULATED PER N104.5.2
- ALL NEW, PERMANENTLY INSTALLED INTERIOR & EXTERIOR LIGHTING FIXTURES CONTAIN HIGH EFFICIENCY LAMPS
- NEW WINDOWS SHALL HAVE U VALUES OF 0.30 OR LESS
- NEW EXTERIOR DOORS SHALL HAVE U-VALUES OF 0.20 OR LESS
- APPROX. 8'-0" HEADER HEIGHT THRU-OUT MAIN FLOOR (95'+)
- 8'-0" TALL FRONT DOOR HEADER HEIGHT APPROX. 8'-3" (93'+)
- STAIR NOTES**
- 16 RISERS @ 1 1/16" = 10'-3 1/4"
- 15 TREADS @ 11" = 13'-9"
- ENERGY EFFICIENCY MEASURES**
- ENVELOPE ENHANCEMENT MEASURE 5: AIR SEALING HOME & DUCTS
- CONSERVATION MEASURE 4: HIGH EFFICIENCY HVAC SYSTEM
- SMOKE DETECTOR
- CARBON MONOXIDE DETECTOR
- 50/20 CFM FAN HARD-DUCTED TO EXTERIOR
- TANKLESS WATER HEATER DIRECT VENT TO EXTERIOR

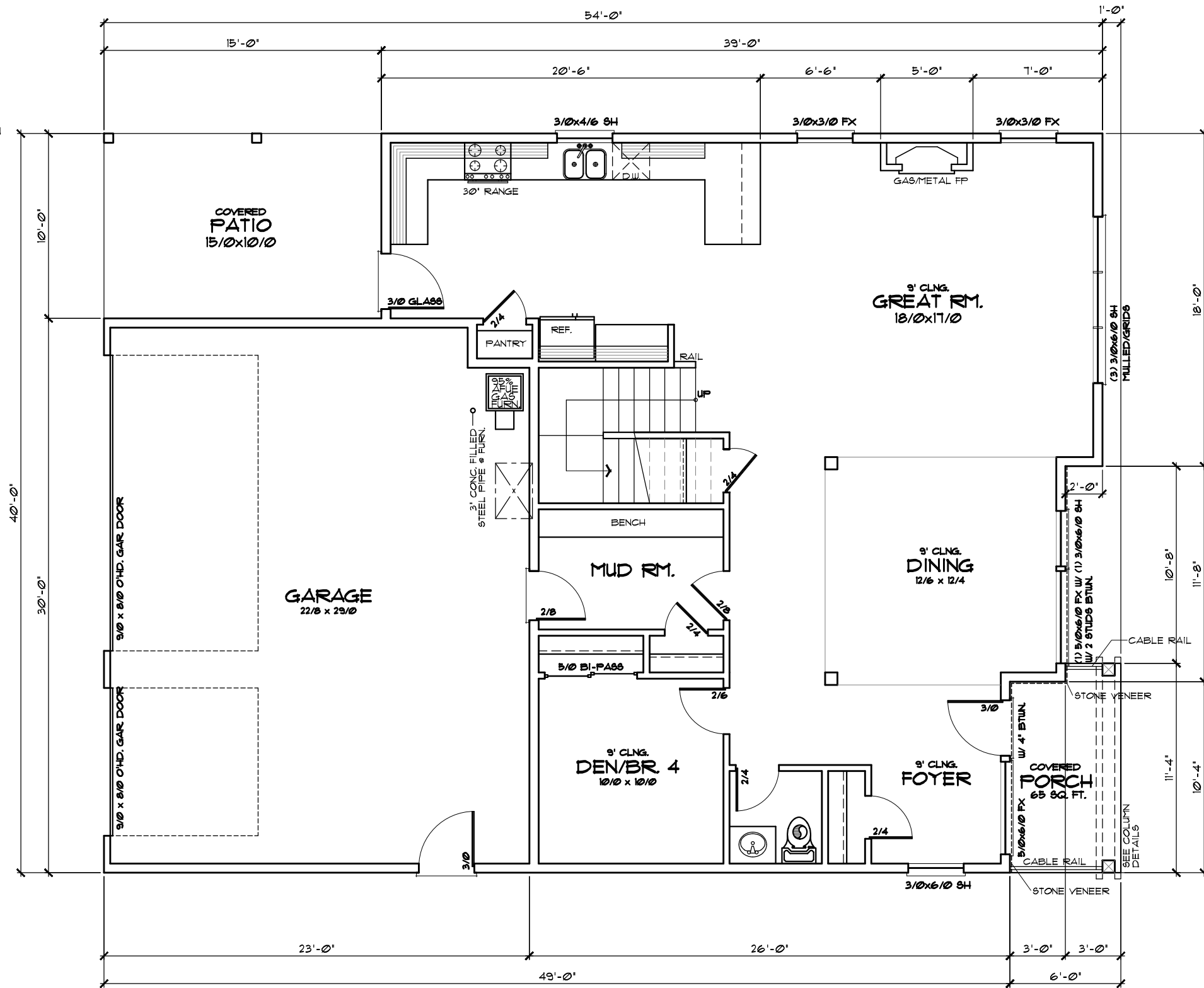

PLAN No. 444mod-PNWM
 DRAWN BY: GF
 DATE: 6/4/2021
 SCALE: 1/4"=1'-0"
 FILE: 444mod-3

MAIN FLOOR PLAN

PNWM

SHEET No.

3

444mod
PNWM
2,760 SQ.FT.

MAIN FLOOR PLAN
 1/4"=1'-0" 1256 SQ.FT.
 GARAGE: 679 SQ.FT.

*SQUARE FOOTAGE IS AN ESTIMATED FIGURE, IT MAY VARY.
 *ALL DIMENSIONS ARE ESTIMATES, SOME MAY VARY.
 *PLANS ARE DESIGNED FOR FLAT LOTS. IF MASONRY IS INCLUDED IN PLAN, THERE IS AN ADDITIONAL CHARGE IF HOME SITE IS NOT FLAT.
 *ARCHITECTURAL DRAWINGS ARE ESTIMATES OF HOW HOME WILL LOOK.

GENERAL NOTES:

- 9'-0" CEILING THRU-OUT UPPER FLOOR PLAN
- 4 X 10 HEADERS TYP. UNLESS NOTED OTHERWISE
VOIDS IN HEADERS TO BE INSULATED W/ MIN R-4 RIGID INSULATION
NON-STRUCTURAL HEADERS MAY BE REPLACED ENTIRELY W/ RIGID INSULATION
- FULL-HEIGHT STUDS REQUIRED AT EACH END OF HEADERS PER R602.1.5
LESS THAN 3'-0" = 1 STUD
LESS THAN 4'-0" = 2 STUDS
LESS THAN 8'-0" = 3 STUDS
LESS THAN 12'-0" = 5 STUDS
LESS THAN 16'-0" = 6 STUDS
- INTERMEDIATE FRAMING FOR EXTERIOR WALLS, TYP.:
2 X 6 STUDS @ 16" O.C.
W/ R-23 BLOWN INSULATION
CORNERS & INTERSECTIONS, TYP.:
TO BE FULLY INSULATED THRU 2" OR 3" STUD CORNER TECHNIQUE PER N104.5.2
- INTERMEDIATE FRAMING FOR INTERIOR WALLS, TYP.:
2 X 4 STUDS @ 16" O.C.
INTERSECTIONS W/ EXTERIOR WALLS TO BE FULLY INSULATED PER N104.5.2
- ALL NEW, PERMANENTLY INSTALLED INTERIOR & EXTERIOR LIGHTING FIXTURES CONTAIN HIGH EFFICIENCY LAMPS
- NEW WINDOWS SHALL HAVE U VALUES OF 0.30 OR LESS
- NEW EXTERIOR DOORS SHALL HAVE U-VALUES OF 0.20 OR LESS
- APPROX. 1'-0" HEADER HEIGHT THRU-OUT UPPER FLOOR (83")

STAIR NOTES

- 16 RISERS @ 1 1/16" = 10'-3 1/4"
- 15 TREADS @ 11" = 13'-9"

ENERGY EFFICIENCY MEASURES

- ENVELOPE ENHANCEMENT MEASURE 5: AIR SEALING HOME & DUCTS
- CONSERVATION MEASURE 4: HIGH EFFICIENCY HVAC SYSTEM

- SMOKE DETECTOR
- CARBON MONOXIDE DETECTOR
- 50/80 CFM FAN HARD-DUCTED TO EXTERIOR

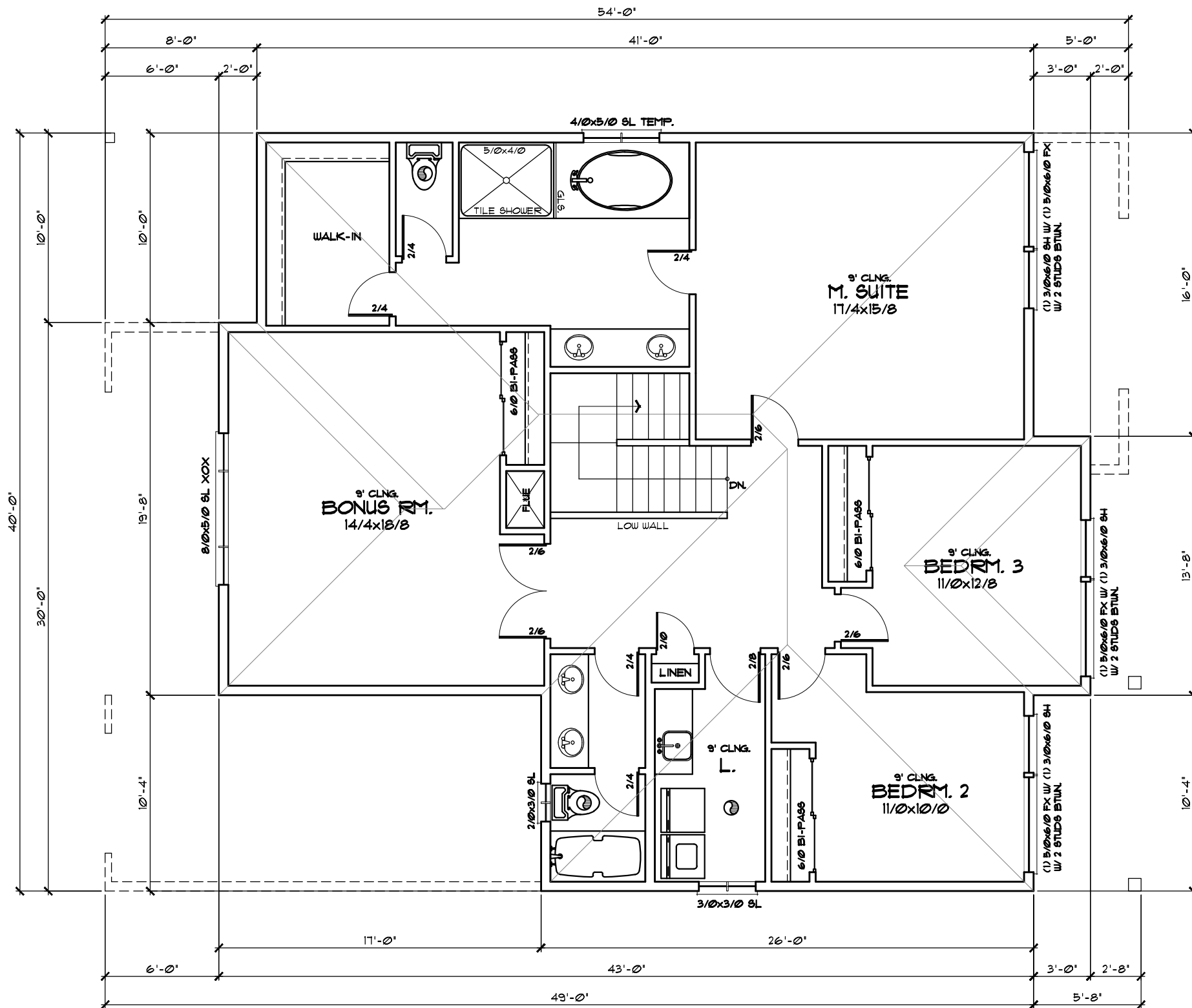

UPPER FLOOR PLAN
 1/4"=1'-0" 1,504 SQ.FT.



PLAN No. 444mod-PNWM
 DRAWN BY: GF
 DATE: 5/21/2021
 SCALE: 1/4"=1'-0"
 FILE: 444mod-4

DRAWINGS:
 UPPER FLOOR PLAN

PNWM

SHEET No.

4

444mod
 PNWM
 2,760 SQ.FT.

Exhibit N: 250-Foot Radius Notification Labels



250 ft Buffer

27227 SW Stafford Rd, Wilsonville, OR 97070

Report Generated: 6/28/2021

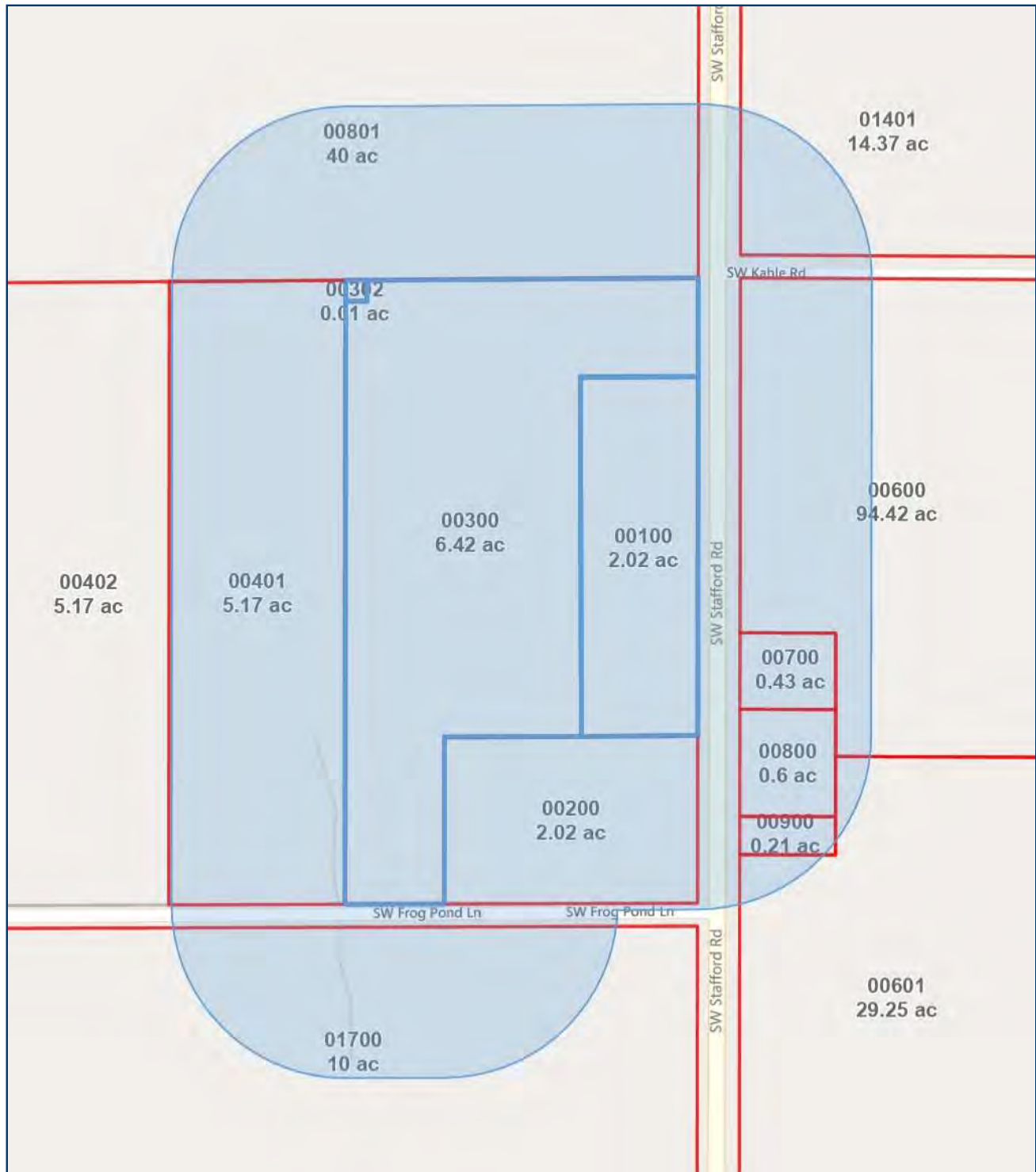

The present data and maps are intended for informational purposes only. Some information has been procured from third-party sources and has not been independently verified. Individual parts are owned by their respective copyright owners and not by First American. First American Title Company makes no express or implied warranty respecting the information presented and assumes no responsibility for errors or omissions.



Date of Production: 06/28/2021

TERMS AND CONDITIONS OF INFORMATION REPORTS

IMPORTANT - READ CAREFULLY: AN INFORMATION REPORT IS **NOT** AN INSURED PRODUCT OR SERVICE OR A REPRESENTATION OF THE CONDITION OF TITLE TO REAL PROPERTY. IT IS NOT AN ABSTRACT, LEGAL OPINION, OPINION OF TITLE, TITLE INSURANCE COMMITMENT OR PRELIMINARY REPORT, OR ANY FORM OF TITLE INSURANCE OR GUARANTY. THE INFORMATION REPORT IS ISSUED EXCLUSIVELY FOR THE BENEFIT OF THE REQUESTOR, AND MAY NOT BE USED OR RELIED UPON BY ANY OTHER PERSON. THE INFORMATION REPORT MAY NOT BE REPRODUCED IN ANY MANNER WITHOUT FIRST AMERICAN TITLE'S PRIOR WRITTEN CONSENT. FIRST AMERICAN TITLE DOES NOT REPRESENT OR WARRANT THAT THE INFORMATION CONTAINED IN THE INFORMATION REPORT IS COMPLETE OR FREE FROM ERROR, AND THE INFORMATION THEREIN IS PROVIDED WITHOUT ANY WARRANTIES OF ANY KIND, AS-IS, AND WITH ALL FAULTS. AS A MATERIAL PART OF THE CONSIDERATION GIVEN IN EXCHANGE FOR THE ISSUANCE OF AN INFORMATION REPORT, REQUESTOR AGREES THAT FIRST AMERICAN TITLE'S SOLE LIABILITY FOR ANY LOSS OR DAMAGE CAUSED BY AN ERROR OR OMISSION DUE TO INACCURATE INFORMATION OR NEGLIGENCE IN PREPARING THE INFORMATION REPORT SHALL BE LIMITED TO THE GREATOR OF THE FEE CHARGED FOR THE INFORMATION REPORT OR \$15. REQUESTOR ACCEPTS THE INFORMATION REPORT WITH THIS LIMITATION AND AGREES THAT FIRST AMERICAN TITLE WOULD NOT HAVE ISSUED THE INFORMATION REPORT BUT FOR THE LIMITATION OF LIABILITY DESCRIBED ABOVE. FIRST AMERICAN TITLE MAKES NO REPRESENTATION OR WARRANTY AS TO THE LEGALITY OR PROPRIETY OF REQUESTOR'S USE OF THE INFORMATION CONTAINED IN THE INFORMATION REPORT.

31E07 00600
Sparkle Anderson
27480 SW Stafford Rd
Wilsonville, OR 97070

31E07 00601
Sparkle Anderson
27480 SW Stafford Rd
Wilsonville, OR 97070

31E07 00700
Sparkle Anderson & Mary Fuller
27480 SW Stafford Rd
Wilsonville, OR 97070

31W12D 00100
Janene & Paul Chaney
27227 SW Stafford Rd
Wilsonville, OR 97070

31W12D 00300
Paul & Janene Chaney
27227 SW Stafford Rd
Wilsonville, OR 97070

31W12D 00302
Janene & Paul Chaney
27227 SW Stafford Rd
Wilsonville, OR 97070

31E07 00800
Grange Frogpond
28750 SW Ashland Loop APT 155
Wilsonville, OR 97070

31E07 00900
Grange Frogpond
28750 SW Ashland Loop APT 155
Wilsonville, OR 97070

31W12 00801
Grill David Glenn & Grill Kellie Poulsen
26801 SW Stafford Rd
Wilsonville, OR 97070

31W12D 00401
Jamison Mehus & Sheri Miller
6725 SW Frog Pond Ln
Wilsonville, OR 97070

31W12D 01700
Venture Properties Inc
4230 Galewood St STE 100
Lake Oswego, OR 97035

31W12D 00200
Adrian & Ana Petras
19674 Wildwood Dr
West Linn, OR 97068

31E07B 01401
Pickles Place Llc
32480 SW Juliette Dr
Wilsonville, OR 97070



Customer Service Department
Phone: 503.219.8746(TRIO)
Email: cs.oregon@firstam.com
Report Generated: 6/28/2021

Ownership

Legal Owner(s): Janene & Paul Chaney

Site Address: 27227 SW Stafford Rd Wilsonville, OR 97070

Mailing Address: 27227 SW Stafford Rd Wilsonville, OR 97070

Parcel #: 31W12D 00100

APN: 00805668

County: Clackamas

Property Characteristics

Bedrooms: 2	Year Built: 1936	Lot SqFt: 87991
Total Bathrooms: 2	Building SqFt: 3047	Lot Acres: 2.02
Full Bathrooms: 2	First Floor SqFt: 0	Roof Type: Wood Shake/
Half Bathrooms: 0	Basement Sqft: 0	Roof Shape: HIP
Units: 0	Basment Type: Unspecified	Porch Type:
Stories: 1.00		Building Style:
Fire Place: Y		Garage: Garage
Air Conditioning:		Garage SqFt: 0
Heating Type: Forced air unit		Parking Spots: 3
Electric Type:		Pool:

Property Information

Land Use: RESIDENTIAL	Zoning: RRRF5
Improvement Type: Rural Residence (Agricultural)	School District: West
Legal Description: SECTION 12 TOWNSHIP 3S RANGE 1W QUARTER D TAX LOT 00100	Neighborhood: Far West
	Subdivision:

Assessor & Tax

Market Land: \$335,589	Taxes: \$4,962.89
Market Total: \$538,429	% Improved: 38
Market Structure: \$202,840	Levy Code: 003028
Assessed Total: \$314,974	Millage Rate: 16.3079

Sale History

Last Sale Date:	Doc #:	Last Sale Price: \$0
Prior Sale Date:	Prior Doc #:	Prior Sale Price: \$0

Mortgage

1st Mortgage Date:	Doc #:	
1st Mortgage Type:	1st Mortgage Lender:	1st Mortgage: \$0
2nd Mortgage Type:		2nd Mortgage: \$0



Customer Service Department
Phone: 503.219.8746(TRIO)
Email: cs.oregon@firstam.com
Report Generated: 6/28/2021

Ownership

Legal Owner(s): Paul & Janene Chaney

Site Address: No Site Address Wilsonville, OR 97070

Mailing Address: 27227 SW Stafford Rd Wilsonville, OR 97070

Parcel #: 31W12D 00300

APN: 00805695

County: Clackamas

Property Characteristics

Bedrooms: 0	Year Built: 0	Lot SqFt: 279655
Total Bathrooms: 0	Building SqFt: 0	Lot Acres: 6.42
Full Bathrooms: 0	First Floor SqFt: 0	Roof Type:
Half Bathrooms:	Basement Sqft: 0	Roof Shape:
Units: 0	Basment Type:	Porch Type:
Stories:		Building Style:
Fire Place: N		Garage:
Air Conditioning:		Garage SqFt: 0
Heating Type:		Parking Spots: 0
Electric Type:		Pool:

Property Information

Land Use: VACANT	Zoning: RRRF5
Improvement Type: Agricultural-Unimproved Vacant Land	School District: West
Legal Description: SECTION 12 TOWNSHIP 3S RANGE 1W QUARTER D TAX LOT 00300	Neighborhood: Far West
	Subdivision:

Assessor & Tax

Market Land: \$519,284	Taxes: \$101.20
Market Total: \$519,284	% Improved: 0
Market Structure: \$0	Levy Code: 003028
Assessed Total: \$6,009	Millage Rate: 16.3079

Sale History

Last Sale Date: 1/16/2001	Doc #: 2001-002679	Last Sale Price: \$62,640
Prior Sale Date:	Prior Doc #:	Prior Sale Price: \$0

Mortgage

1st Mortgage Date:	Doc #:	
1st Mortgage Type:	1st Mortgage Lender:	1st Mortgage: \$0
2nd Mortgage Type:		2nd Mortgage: \$0



Customer Service Department
Phone: 503.219.8746(TRIO)
Email: cs.oregon@firstam.com
Report Generated: 6/28/2021

Ownership

Legal Owner(s): Janene & Paul Chaney

Site Address: No Site Address Wilsonville, OR 97070

Mailing Address: 27227 SW Stafford Rd Wilsonville, OR 97070

Parcel #: 31W12D 00302

APN: 05023079

County: Clackamas

Property Characteristics

Bedrooms: 0	Year Built: 0	Lot SqFt: 436
Total Bathrooms: 0	Building SqFt: 0	Lot Acres: 0.01
Full Bathrooms: 0	First Floor SqFt: 0	Roof Type:
Half Bathrooms:	Basement Sqft: 0	Roof Shape:
Units: 0	Basment Type:	Porch Type:
Stories:		Building Style:
Fire Place: N		Garage:
Air Conditioning:		Garage SqFt: 0
Heating Type:		Parking Spots: 0
Electric Type:		Pool:

Property Information

Land Use: VACANT	Zoning: RRRF5
Improvement Type: Agricultural-Unimproved Vacant Land	School District: West
Legal Description: TOWNSHIP 3S RANGE 1W SECTION 12 QUARTER D TAX LOT 00302	Neighborhood: Far West
	Subdivision:

Assessor & Tax

Market Land: \$808	Taxes: \$0.15
Market Total: \$808	% Improved: 0
Market Structure: \$0	Levy Code: 003028
Assessed Total: \$9	Millage Rate: 16.3079

Sale History

Last Sale Date:	Doc #:	Last Sale Price: \$0
Prior Sale Date:	Prior Doc #:	Prior Sale Price: \$0

Mortgage

1st Mortgage Date:	Doc #:	
1st Mortgage Type:	1st Mortgage Lender:	1st Mortgage: \$0
2nd Mortgage Type:		2nd Mortgage: \$0



Customer Service Department
 Phone: 503.219.8746(TRIO)
 Email: cs.oregon@firstam.com
 Report Generated: 6/28/2021

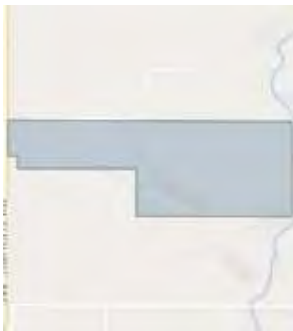

Legal Owner: Sparkle Anderson
Site Address: No Site Address Wilsonville, OR 97070
Mailing Address: 27480 SW Stafford Rd Wilsonville, OR
Bedrooms: 0
Bathrooms: 0
Building SqFt: 0 **Lot Acres:** 94.42
Year Built: 0
School District: West Linn-Wilsonville School Distr
Neighborhood: Far West
Legal: SECTION 07 TOWNSHIP 3S RANGE 1E TAX LOT 00600

APN: 756667
Ref Parcel #: 31E07 00600
Taxes: \$1,219.30
Market Value: \$571,539
Assessed Value: \$72,401
Sales Price: \$0
Transfer Date:



Legal Owner: Sparkle Anderson
Site Address: 27480 SW Stafford Rd Wilsonville, OR 97070
Mailing Address: 27480 SW Stafford Rd Wilsonville, OR
Bedrooms: 4
Bathrooms: 1
Building SqFt: 3,688 **Lot Acres:** 29.25
Year Built: 1900
School District: West Linn-Wilsonville School Distr
Neighborhood: Far West
Legal: SECTION 07 TOWNSHIP 3S RANGE 1E TAX LOT 00601

APN: 756676
Ref Parcel #: 31E07 00601
Taxes: \$2,842.17
Market Value: \$836,173
Assessed Value: \$168,765
Sales Price: \$0
Transfer Date: 6/1/1993

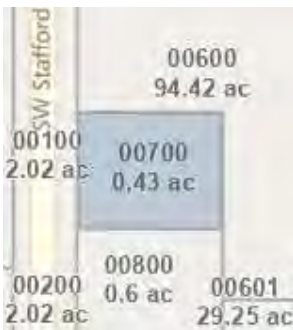

Legal Owner: Sparkle Anderson & Mary Fuller
Site Address: No Site Address Wilsonville, OR 97070
Mailing Address: 27480 SW Stafford Rd Wilsonville, OR
Bedrooms: 0
Bathrooms: 0
Building SqFt: 0 **Lot Acres:** 0.43
Year Built: 0
School District: West Linn-Wilsonville School Distr
Neighborhood: Far West
Legal: SECTION 07 TOWNSHIP 3S RANGE 1E TAX LOT 00700

APN: 756685
Ref Parcel #: 31E07 00700
Taxes: \$101.52
Market Value: \$10,740
Assessed Value: \$6,028
Sales Price: \$0
Transfer Date:



Legal Owner: Janene & Paul Chaney
Site Address: 27227 SW Stafford Rd Wilsonville, OR 97070
Mailing Address: 27227 SW Stafford Rd Wilsonville, OR
Bedrooms: 2
Bathrooms: 2
Building SqFt: 3,047 **Lot Acres:** 2.02
Year Built: 1936
School District: West Linn-Wilsonville School Distr
Neighborhood: Far West
Legal: SECTION 12 TOWNSHIP 3S RANGE 1W QUARTER D TAX LOT 00100

APN: 805668
Ref Parcel #: 31W12D 00100
Taxes: \$4,962.89
Market Value: \$538,429
Assessed Value: \$314,974
Sales Price: \$0
Transfer Date:



Customer Service Department
 Phone: 503.219.8746(TRIO)
 Email: cs.oregon@firstam.com
 Report Generated: 6/28/2021



Legal Owner: Paul & Janene Chaney
Site Address: No Site Address Wilsonville, OR 97070
Mailing Address: 27227 SW Stafford Rd Wilsonville, OR
Bedrooms: 0
Bathrooms: 0
Building SqFt: 0 **Lot Acres:** 6.42
Year Built: 0
School District: West Linn-Wilsonville School Distr
Neighborhood: Far West
Legal: SECTION 12 TOWNSHIP 3S RANGE 1W QUARTER D TAX LOT 00300

APN: 805695
Ref Parcel #: 31W12D 00300
Taxes: \$101.20
Market Value: \$519,284
Assessed Value: \$6,009
Sales Price: \$62,640
Transfer Date: 1/16/2001

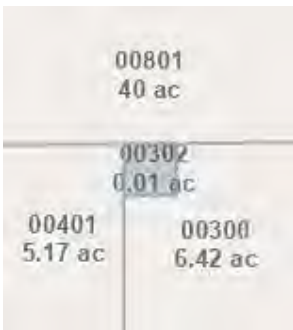

Legal Owner: Janene & Paul Chaney
Site Address: No Site Address Wilsonville, OR 97070
Mailing Address: 27227 SW Stafford Rd Wilsonville, OR
Bedrooms: 0
Bathrooms: 0
Building SqFt: 0 **Lot Acres:** 0.01
Year Built: 0
School District: West Linn-Wilsonville School Distr
Neighborhood: Far West
Legal: TOWNSHIP 3S RANGE 1W SECTION 12 QUARTER D TAX LOT 00302

APN: 5023079
Ref Parcel #: 31W12D 00302
Taxes: \$0.15
Market Value: \$808
Assessed Value: \$9
Sales Price: \$0
Transfer Date:

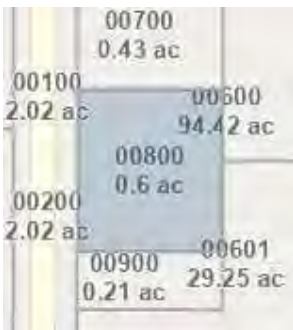

Legal Owner: Grange Frogpond
Site Address: 27350 SW Stafford Rd Wilsonville, OR 97070
Mailing Address: 28750 SW Ashland Loop APT 155
Bedrooms: 0
Bathrooms: 0
Building SqFt: 0 **Lot Acres:** 0.60
Year Built: 1922
School District: West Linn-Wilsonville School Distr
Neighborhood: Far West
Legal: SECTION 07 TOWNSHIP 3S RANGE 1E TAX LOT 00800

APN: 756694
Ref Parcel #: 31E07 00800
Taxes: \$0.00
Market Value: \$406,721
Assessed Value: \$261,928
Sales Price: \$0
Transfer Date:

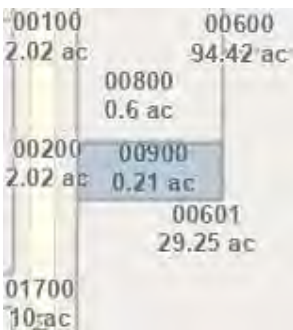

Legal Owner: Grange Frogpond
Site Address: 27350 SW Stafford Rd Wilsonville, OR 97070
Mailing Address: 28750 SW Ashland Loop APT 155
Bedrooms: 0
Bathrooms: 0
Building SqFt: 0 **Lot Acres:** 0.21
Year Built: 0
School District: West Linn-Wilsonville School Distr
Neighborhood: Far West
Legal: SECTION 07 TOWNSHIP 3S RANGE 1E TAX LOT 00900

APN: 756701
Ref Parcel #: 31E07 00900
Taxes: \$0.00
Market Value: \$37,843
Assessed Value: \$24,371
Sales Price: \$0
Transfer Date:



Customer Service Department
 Phone: 503.219.8746(TRIO)
 Email: cs.oregon@firstam.com
 Report Generated: 6/28/2021



Legal Owner: Grill David Glenn & Grill Kellie Poulsen
Site Address: 26801 SW Stafford Rd Wilsonville, OR 97070
Mailing Address: 26801 SW Stafford Rd Wilsonville, OR
Bedrooms: 5
Bathrooms: 2.5
Building SqFt: 3,582 **Lot Acres:** 40.00
Year Built: 1992
School District: West Linn-Wilsonville School Distr
Neighborhood: Far West
Legal: 1991-43 PARTITION PLAT PARCEL 2

APN: 1450432
Ref Parcel #: 31W12 00801
Taxes: \$7,758.28
Market Value: \$1,493,376
Assessed Value: \$491,548
Sales Price: \$630,000
Transfer Date: 4/1/2003



Legal Owner: Jamison Mehus & Sheri Miller
Site Address: 6725 SW Frog Pond Ln Wilsonville, OR 97070
Mailing Address: 6725 SW Frog Pond Ln Wilsonville, OR
Bedrooms: 2
Bathrooms: 2
Building SqFt: 1,399 **Lot Acres:** 5.17
Year Built: 1960
School District: West Linn-Wilsonville School Distr
Neighborhood: Far West
Legal: SECTION 12 TOWNSHIP 3S RANGE 1W QUARTER D TAX LOT 00401

APN: 805720
Ref Parcel #: 31W12D 00401
Taxes: \$2,775.62
Market Value: \$604,429
Assessed Value: \$164,813
Sales Price: \$0
Transfer Date:



Legal Owner: Venture Properties Inc
Site Address: 6720 SW Frog Pond Ln Wilsonville, OR 97070
Mailing Address: 4230 Galewood St STE 100 Lake Oswego,
Bedrooms: 3
Bathrooms: 1.5
Building SqFt: 1,920 **Lot Acres:** 10.00
Year Built: 1965
School District: West Linn-Wilsonville School Distr
Neighborhood: Far West
Legal: SECTION 12 TOWNSHIP 3S RANGE 1W QUARTER D TAX LOT 01700

APN: 805891
Ref Parcel #: 31W12D 01700
Taxes: \$4,309.06
Market Value: \$908,006
Assessed Value: \$268,170
Sales Price: \$11,400,000
Transfer Date: 6/1/2021

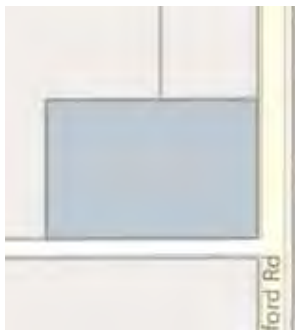

Legal Owner: Adrian & Ana Petras
Site Address: No Site Address Wilsonville, OR 97070
Mailing Address: 19674 Wildwood Dr West Linn, OR 97068
Bedrooms: 0
Bathrooms: 0
Building SqFt: 0 **Lot Acres:** 2.02
Year Built: 0
School District: West Linn-Wilsonville School Distr
Neighborhood: Far West
Legal: SECTION 12 TOWNSHIP 3S RANGE 1W QUARTER D TAX LOT 00200

APN: 805677
Ref Parcel #: 31W12D 00200
Taxes: \$3,357.37
Market Value: \$297,492
Assessed Value: \$199,357
Sales Price: \$320,000
Transfer Date: 4/13/2015



Customer Service Department
Phone: 503.219.8746(TRIO)
Email: cs.oregon@firstam.com
Report Generated: 6/28/2021



Legal Owner: Pickles Place Llc
Site Address: No Site Address Wilsonville, OR 97070
Mailing Address: 32480 SW Juliette Dr Wilsonville, OR 97070
Bedrooms: 0
Bathrooms: 0
Building SqFt: 0 **Lot Acres:** 14.37
Year Built: 0
School District: West Linn-Wilsonville School Distr
Neighborhood: Far West
Legal: 557 TURNER LITTLE FARMS LTS 9-11

APN: 1742421
Ref Parcel #: 31E07B 01401
Taxes: \$316.01
Market Value: \$873,044
Assessed Value: \$18,764
Sales Price: \$362,500
Transfer Date: 3/21/2013

Exhibit O: BPA Easement

TRANSMISSION LINE EASEMENT

The GRANTOR, herein styled whether one or more, GOLDIE G. WILLIS, an unmarried widow, owner, and ARNOLD J. EIDAN, a single man, contract purchaser,

for and in consideration of the sum of - - - - - FOUR THOUSAND FOUR HUNDRED - - - - - Dollars (\$4,400.00), in hand paid by the UNITED STATES OF AMERICA, receipt of which is hereby acknowledged, hereby grants, bargains, sells, and conveys to the UNITED STATES OF AMERICA and its assigns, a perpetual easement and right to enter and erect, maintain, repair, rebuild, operate, and patrol two line(s) of electric power transmission structures and appurtenant signal lines, including the right to erect such poles, transmission structures, wires, cables, and appurtenances as are necessary thereto, in, over, upon, and across the following-described parcel of land in the County of Clackamas, in the State of Oregon, to-wit:

Recorded By Pioneer National Title Insurance Company

That portion of the following described tract which lies northeasterly of a line which is 75 feet southwesterly from and parallel with the survey line of the United States of America for its Bonneville Power Administration's Oregon City-Marcola No. 1 transmission line:

Beginning at a point 1749 feet north and 30 feet west of the southeast corner of Section 12, Township 3 South, Range 1 West, Willamette Meridian, thence North parallel to the Willamette Meridian 858 feet to a point; thence West parallel to south line of Section 12, Township 3 South, Range 1 West, Willamette Meridian, 507.7 feet to a point; thence South parallel to Willamette Meridian, 858 feet; thence East 507.7 feet to the place of beginning. EXCEPT the north 60 feet thereof.

The survey line of said Oregon City-Marcola No. 1 transmission line is described as follows:

Handwritten initials

Beginning in the east line of Section 12, Township 3 South, Range 1 West, Willamette Meridian, 2304.3 feet from the southeast corner of said Section 12; thence, N. 51°37'20" W. 2386.9 feet; thence N. 88°47'30" W. 739.0 feet to a point in the North-South quarter section line, north 1098.7 feet from the center of said Section marked by a one-inch iron pipe (X=612,620.0, X=1,420,650.5).

The bearings and coordinates of said survey line refer to the Oregon Coordinate System - North Zone.

The filbert trees may remain on the right of way except where they will interfere with structure locations, and provided they are kept topped, by the owner, to a height not to exceed 18 feet. Any trees exceeding this limitation may be removed by the United States of America without further compensation by giving 90 days written notice to the owners thereof, of its intention.

Any fences altered during construction shall be repaired by the United States of America and left in as good condition as they were before the start of construction.

The United States of America shall have the right, in connection with maintenance of such part of the right of way as is not otherwise being utilized by the servient owner, to grade, cultivate and plant grass and shrubs thereon, and thereafter to maintain such plantings;



together with the present and future right to clear said right of way and keep the same clear of brush, timber, structures, and fire hazards, provided that fire hazards shall not be interpreted to include any growing crops other than trees.

TO HAVE AND TO HOLD said easement and rights unto the UNITED STATES OF AMERICA and its assigns, forever.

The Grantor covenants to and with the UNITED STATES OF AMERICA and its assigns that the title to all brush, timber or structures existing upon the right of way on February 15, 1967 shall vest in the UNITED STATES OF AMERICA on said date; and that the consideration stated herein is accepted by the Grantor as full compensation for all damages incidental to the exercise of the rights granted hereunder.

The Grantor also covenants to and with the UNITED STATES OF AMERICA that Grantor is lawfully seized and possessed of the lands aforesaid; has a good and lawful right and power to sell and convey same; that same are free and clear of encumbrances, except as above indicated; and that Grantor will forever warrant and defend the title to said easement and the quiet possession thereof against the lawful claims and demands of all persons whomsoever.

Dated this 2 day of May, 1967

Goldie G. Willis
Goldie G. Willis

Arnold J. Eldam
Arnold J. Eldam

BOOK 691 PAGE 861

7463 II

STATE OF Oregon)
) ss:
COUNTY OF Clackamas

On the 16 day of May, 1967 personally came before me, a notary public in and for said County and State, the within-named GOLDIE G. WILSON, a single,

to me personally known to be the identical person described in and who executed the within and foregoing instrument and acknowledged to me that she executed the same as her free and voluntary act and deed, for the uses and purposes therein mentioned.

GIVEN under my hand and official seal the day and year last above written.



G.E. Johnson
Notary Public in and for the
State of Oregon
Residing at Portland
My commission expires:
Sept. 20, 1969

STATE OF Oregon)
) ss:
COUNTY OF Clackamas

On the 2 day of May, 1967, personally came before me, a notary public in and for said County and State, the within-named ANGELA S. WILSON, a single woman,

to me personally known to be the identical person described in and who executed the within and foregoing instrument and acknowledged to me that she executed the same as her free and voluntary act and deed, for the uses and purposes therein mentioned.

GIVEN under my hand and official seal the day and year last above written.



G.E. Johnson
Notary Public in and for the
State of Oregon
Residing at Portland
My commission expires:
Sept. 20, 1969

STATE OF)
) ss:
COUNTY OF)

I CERTIFY that the within instrument was received for the record on the _____ day of _____, 19____, at _____ M., and recorded in book _____ on page _____, records of _____ of said County.

Witness my hand and seal of County affixed.

By _____ Deputy.

After recording, please return to:

TITLE SECTION, BRANCH OF LAND BOOK: **691 PAGE 862**
BONNEVILLE POWER ADMINISTRATION
P.O. BOX No. 2222 3021

BPA 177
Rev. 8-2-61

ORIGINAL DOCUMENT.
on 1-17-67

9463

RECORDED JUN 14 1967

M ROBERT SCHUMACHER, County Clerk

TRANSMISSION LINE EASEMENT

The GRANTOR, herein so styled whether one or more, **HURF YOUNG and BETTY YOUNG, husband and wife,**

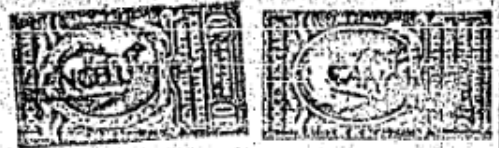

for and in consideration of the sum of - **FOURTEEN THOUSAND ONE HUNDRED** - - - - - Dollars (\$ **14,100.00**),

in hand paid by the UNITED STATES OF AMERICA, receipt of which is hereby acknowledged, hereby grants, bargains, sells, and conveys to the UNITED STATES OF AMERICA and its assigns, a perpetual easement and right to enter and erect, maintain, repair, rebuild, operate, and patrol **two** line(s) of electric power transmission structures and appurtenant signal lines, including the right to erect such poles, transmission structures, wires, cables, and appurtenances as are necessary thereto, in, over, upon, and across the following-described parcel of land in the County of **Clackamas**, in the State of **Oregon**, to-wit:

Those portions of the following described tracts which lie northeasterly of a line which is 75 feet southwesterly from and parallel with the survey line of the United States of America for its Bonneville Power Administration's Oregon City-Marcola No. 1 transmission line:

PARCEL A: Part of Section 12, Township 3 South, Range 1 West of the Willamette Meridian described as follows: Beginning at a point 1749 feet north and 30 feet west of the southeast corner of said Section 12; thence North, parallel with the Willamette Meridian 856 feet to the true place of beginning; thence West parallel with the south line of Section 12 a distance of 507.07 feet to a point; thence South parallel to the Willamette Meridian a distance of 60 feet; thence East 507.07 feet; thence North 60 feet to the place of beginning.

PARCEL B: Beginning at the northeast corner of the southeast one-quarter of Section 12, Township 3 South, Range 1 West of the Willamette Meridian, Clackamas County, Oregon; thence West 507.70 feet to the center line; thence South at right angles 29.70 feet; thence East parallel to the south line of Section 12, 507.70 feet to the east line of said Section; thence North to the place of beginning, EXCEPT that part lying within the boundaries of Public Roads.

The survey line for said Oregon City-Marcola No. 1 transmission line is described as follows:

Beginning in the east line of Section 12, Township 3 South, Range 1 West, Willamette Meridian, 2304.3 feet from the southeast corner of said Section 12, thence N. 51°37'20" W. 2386.9 feet; thence N. 85°47'30" W. 739.0 feet to a point in the north-south quarter section line, north 1096.7 feet from the center of said Section 12, marked by a one-inch iron pipe (Y-612,620.0, X-1420,650.5).

The bearings and coordinates of said survey line are referred to the Oregon Coordinate System--North Zone;

together with all necessary and convenient access over, along and across existing roads on premises owned by the Grantor within existing Bonneville Power Administration easements.

It is understood and agreed that the consideration named herein includes payment for the dwelling and shed upon the above described property. The Grantors shall be entitled to remain in possession of said buildings until 90 days after payment is made by the United States of America, provided that the Grantors shall not unreasonably delay in executing the easement and voucher certificate and provided the title is clear. Grantors covenant and agree that the United States of America shall not be liable for any damage or injury to persons or property resulting directly or indirectly from such possession, except as provided by the Federal Tort Claims Act, 28 Stat. 922, as amended.

The Grantors named herein further agree to notify the United States of America of their intent to move three days prior to such move in order that proper arrangements can be made for delivery of keys to the property by the Grantors to the United States of America.

Any surface damage to land involved and deep cuts or ditches created by clearing and construction work shall be filled and leveled and left in as level a state as at all times. It is understood that no crops exist at this time to be damaged by construction and no claim will be submitted therefor.

It is further understood and agreed that the Grantors shall retain the well and power system at approximately 100 feet in depth, providing that no further construction shall be made and no appurtenances shall be made by the present power arrangement. It is further understood and agreed that the Grantors shall be responsible for the repair and maintenance of the well and power system and shall be held liable for any damage or injury to persons or property resulting directly or indirectly from such possession, except as provided by the Federal Tort Claims Act, 28 Stat. 922, as amended.

11012

Insured By
Fidelity National
Title Insurance Company

1821

The United States of America shall have the right, in connection with the maintenance of such part of the right of way as is not otherwise being utilized by the servient owner, to grade, cultivate and plant grass and shrubs thereon, and thereafter to maintain such plantings;

together with the present and future right to clear said right of way and keep the same clear of brush, timber, structures, and fire hazards, provided that fire hazards shall not be interpreted to include any growing crops other than trees.

TO HAVE AND TO HOLD said easement and rights unto the UNITED STATES OF AMERICA and its assigns, forever.

The Grantor covenants to and with the UNITED STATES OF AMERICA and its assigns that the title to all brush, timber or structures existing upon the right of way on February 20, 1967 shall vest in the UNITED STATES OF AMERICA on said date; and that the consideration stated herein is accepted by the Grantor as full compensation for all damages incidental to the exercise of the rights granted hereunder.

The Grantor also covenants to and with the UNITED STATES OF AMERICA that Grantor is lawfully seized and possessed of the lands aforesaid; has a good and lawful right and power to sell and convey same; that same are free and clear of encumbrances, except as above indicated; and that Grantor will forever warrant and defend the title to said easement and the quiet possession thereof against the lawful claims and demands of all persons whatsoever.

Dated this 2 day of May, 1967

Maud Young
Maud Young
Betty Young
Betty Young

72817

630 MAY 24

STATE OF *Oregon*)
COUNTY OF *Clatsop*) SS:

On the *2* day of *May*, 19*67*, personally came before me, a notary public in and for said County and State, the within-named *MURL YOUNG and BETTY YOUNG*, husband and wife, to me personally known to be the identical persons described in and who executed the within and foregoing instrument and acknowledged to me that they executed the same as their free and voluntary act and deed, for the uses and purposes therein mentioned.

GIVEN under my hand and official seal the day and year last above written.



C.E. Johnson
Notary Public in and for the
State of *Oregon*
Residing at *Portland*

My commission expires:
Sept. 20, 1969

III
1322

STATE OF)
COUNTY OF)

I CERTIFY that the within instrument was received for the record on the *2* day of *May*, 19*67*, at *Portland*, *Or.*, and recorded in book *7281* on page *25*, records of said County.

Witness my hand and seal of County affixed.

REAL DOCUMENT *7281* RECORDED MAY 12 1967 11:29 P.M. ROBERT SCHUMACHER, County Clerk

Please send return to:

TITLE SECTION, DEPT. OF LAND
BONNEVILLE POWER ADMINISTRATION
P.O. BOX 307
PORTLAND, OREGON 97208

BOOK *7281* PAGE *25*

BPA 172A
MAY 1967

date 1-13-67

100

In CONSIDERATION of the sum of Ten and no/100 DOLLARS, Jay H. Cook and Fern S. Cook, husband and wife to them in hand paid, the receipt whereof is hereby acknowledged do hereby convey, assign, sell, transfer and set over unto Leo B. Adkins and Ethel M. Adkins, husband and wife

all their right, title and interest in and to the written and attached contract of sale dated April 28, 1960 between EARL BURNS and ELLEN BURNS, husband and wife and JAY H. COOK and FERN S. COOK, husband and wife and in and to the real property described therein, and upon full compliance or covenants with the terms of said contract do authorize and direct that conveyance be made to such assignee.

Description: A tract in the S.E. 1/4 of Sec. 1, T.5,S.R.2,E. of the W.M. more particularly described in Deed Book 31, page 20, Clackamas County Records.

IN WITNESS WHEREOF, we have hereunto set our hand and seal this 10 day of May, 1967.

Jay H. Cook (SEAL) Fern S. Cook (SEAL)

STATE OF OREGON, County of Lane } ss. On this 10 day of May, 1967, before me, the undersigned, a Notary Public in and for said County and State, personally appeared the within named JAY H. COOK and FERN S. COOK, husband and wife who known to me to be the identical individuals described in and who executed the within instrument, and acknowledged to me that they executed the same freely and voluntarily.

IN TESTIMONY WHEREOF, I have hereunto set my hand and affixed my official seal the day and year last above written.

Gail O'Hayt Cook Notary Public for Oregon My commission expires August 8, 1970

7283 Recorded By Pioneer National Title Insurance Company

Exhibit P: TVF&R Service Provider Letter

**FIRE CODE / LAND USE / BUILDING REVIEW
APPLICATION**



North Operating Center
11945 SW 70th Avenue
Tigard, OR 97223
Phone: 503-649-8577

South Operating Center
8445 SW Elligsen Rd
Wilsonville, OR 97070
Phone: 503-649-8577

REV 6-30-20

Project Information

Applicant Name: Venture Properties, LLC
Address: 4230 Galewood Street, Suite 100
Phone: please contact Applicant's consultant
Email: mariam@aks-eng.com, 503-563-6151
Site Address: 27227 SW Stafford Road
City: Wilsonville
Map & Tax Lot #: 31W12D, Tax Lots 100,300,302
Business Name: Frog Pond Crossing
Land Use/Building Jurisdiction: City of Wilsonville
Land Use/ Building Permit # DB21-0036

Choose from: Beaverton, Tigard, Newberg, Tualatin, North Plains, West Linn, **Wilsonville**, Sherwood, Rivergrove, Durham, King City, Washington County, Clackamas County, Multnomah County, Yamhill County

Project Description

29-lot single-family detached residential subdivision on a ±8.46 acre site

Permit/Review Type (check one):

- Land Use / Building Review - Service Provider Permit
- Emergency Radio Responder Coverage Install/Test
- LPG Tank (Greater than 2,000 gallons)
- Flammable or Combustible Liquid Tank Installation (Greater than 1,000 gallons)
 - * Exception: Underground Storage Tanks (UST) are deferred to DEQ for regulation.
- Explosives Blasting (Blasting plan is required)
- Exterior Toxic, Pyrophoric or Corrosive Gas Installation (in excess of 810 cu.ft.)
- Tents or Temporary Membrane Structures (in excess of 10,000 square feet)
- Temporary Haunted House or similar
- OLCC Cannabis Extraction License Review
- Ceremonial Fire or Bonfire (For gathering, ceremony or other assembly)

For Fire Marshal's Office Use Only

TVFR Permit # 2021-0087
Permit Type: SPP-COW
Submittal Date: 2-18-21
Assigned To: DFM Arn
Due Date: _____
Fees Due: ∅
Fees Paid: ∅

Approval/Inspection Conditions
(For Fire Marshal's Office Use Only)

This section is for application approval only

[Signature] 0430 8-18-21
Fire Marshal or Designee Date

Conditions:

See Attached Conditions: Yes No

Site Inspection Required: Yes No

This section used when site inspection is required

Inspection Comments:

Final TVFR Approval Signature & Emp ID Date



TAX LOT 1401
TAX MAP 31E7B

SW KAHLE ROAD

TAX LOT 801
TAX MAP 31W12

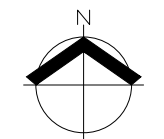

SCALE: 1" = 50 FEET
ORIGINAL PAGE SIZE: 22" x 34"



APPROVAL OF PLANS IS NOT AN APPROVAL OF OMISSIONS OR OVERSIGHTS

James J. Gale
Deputy Fire Marshal II

SPP-COW 2021-0087

TAX LOT 402
TAX MAP 31W12D

TAX LOT 401
TAX MAP 31W12D

TAX LOT 600
TAX MAP 31E7

TAX LOT 700
TAX MAP 31E7

TAX LOT 800
TAX MAP 31E7

TAX LOT 900
TAX MAP 31E7

TAX LOT 200
TAX MAP 31W12D

TAX LOT 601
TAX MAP 31E7

FS-1

EASEMENT LEGEND	
PUE	PUBLIC UTILITY EASEMENT
PAUE	PUBLIC ACCESS AND UTILITY EASEMENT
SWE	SIDEWALK EASEMENT

PRELIMINARY COMPOSITE UTILITY PLAN
FROG POND CROSSING
VENTURE PROPERTIES, INC.
WILSONVILLE, OREGON



RENEW: DECEMBER 31, 2021
JOB NUMBER: 5252
DATE: 07/14/2021
DESIGNED BY: AJD
DRAWN BY: NLB
CHECKED BY: MD

Exhibit Q: Fire Truck Turning Exhibit

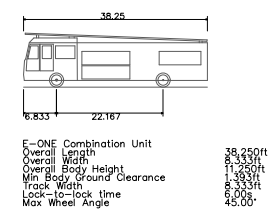
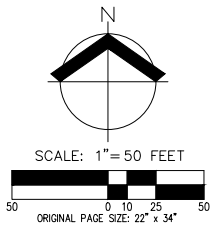
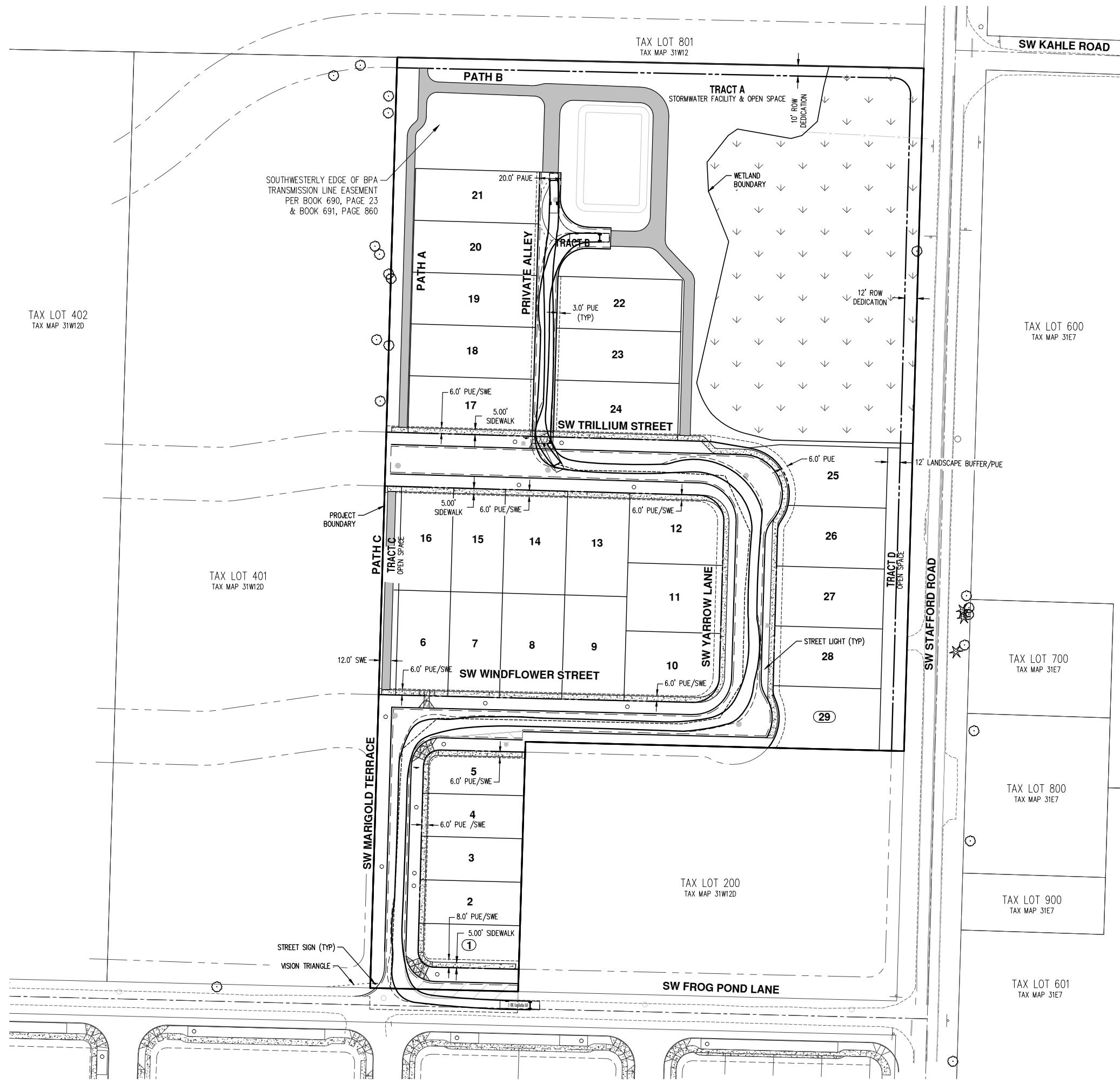

- LEGEND**
- SIDEWALK AND DRIVEWAY APPROACHES TO BE INSTALLED BY HOMEBUILDER.
 - SIDEWALK AND DRIVEWAY APPROACHES TO BE INSTALLED BY CONTRACTOR.
 - STORMWATER SWALE TO BE CONSTRUCTED BY CONTRACTOR.
 - STORMWATER RAIN GARDEN TO BE CONSTRUCTED BY HOMEBUILDER.
 - TRAIL TO BE CONSTRUCTED BY CONTRACTOR.
 - ASPHALT CONCRETE PAVEMENT
 - EXISTING WETLAND

- EASEMENT LEGEND**
- PUE PUBLIC UTILITY EASEMENT
 - PAUE PUBLIC ACCESS AND UTILITY EASEMENT
 - SWE SIDEWALK EASEMENT

**FIRE TRUCK TURNING EXHIBIT
FROG POND CROSSING
VENTURE PROPERTIES, INC.
WILSONVILLE, OREGON**

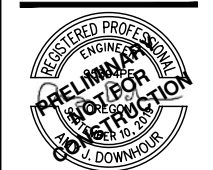

RENEWALS: DECEMBER 31, 2021
 JOB NUMBER: 5252
 DATE: 08/25/2021
 DESIGNED BY: AJD
 DRAWN BY: NLB
 CHECKED BY: MD

Exhibit U: Republic Services Site Plan Approval

Maria Miller

From: Herrod, Kelly <KHerrod@republicservices.com>
Sent: Friday, November 12, 2021 4:52 PM
To: Maria Miller
Cc: Michelle Swartout; Amy Downhour; Olivares, John
Subject: RE: Frog Pond Crossing subdivision - Trash Service Provider

Categories: Filed by Newforma

EXTERNAL EMAIL: This email originated from outside AKS Engineering & Forestry.

Hello Maria,

The private alley turn-around space in your design plan in tract B should be adequate for our trucks to turn around.

The design plan appears to have a temporary dead-end on SW Trillium St. affecting lots 14, 15, 16. There are hazards associated with having our trucks back into this dead-end to service the affected lots. We will require interim waste pickup along SW Trillium Street at the locations specified in the attached diagram with the trash & recycle carts place in front of lot 12-13, or parallel to lot 24 until the future extension for this street has been completed. The interim requirement will need be addressed with specific recorded CC&Rs against the lots with compliance and enforcement by the HOA. Future changes to service for the affected lots will need to be approved by Republic Services.

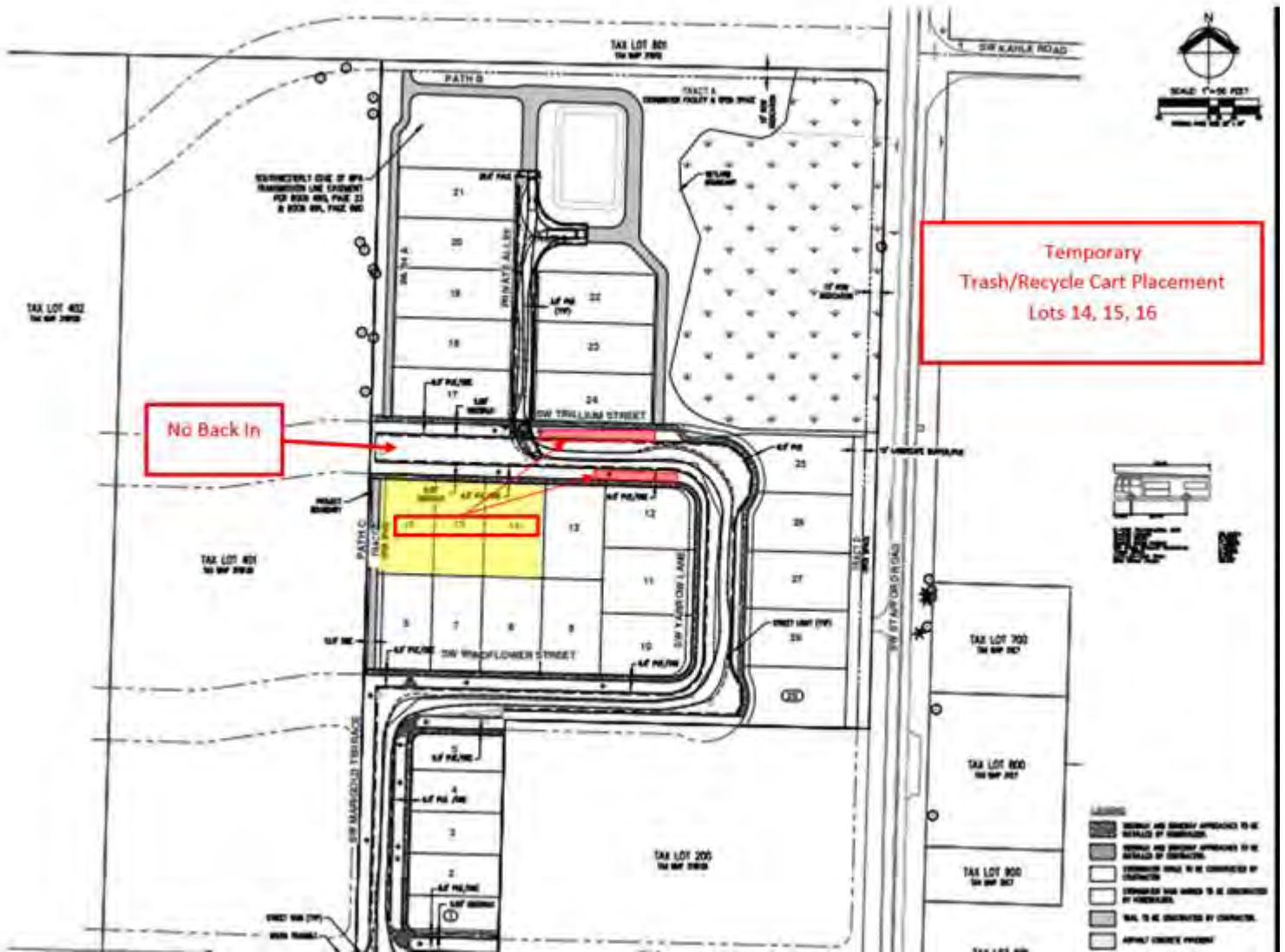

Kelly Herrod
 Operations Supervisor
 Clackamas / Washington Counties
 Wilsonville / Tualatin / Lake Oswego

10295 SW Ridder Rd.,
 Wilsonville, OR 97070
 e kherrod@republicservices.com
 o 503-404-4181 c 503-849-0926
 w RepublicServices.com



We'll handle it from here.™